

The C-Class.

Coupé.



Mercedes-Benz

This Brochure is prepared by Daimler AG and it predominantly reflects the capabilities and performance of vehicles sold in Europe.

Some characteristics, capabilities, performance features and optional extras (e.g. towing systems) may not be available or may not apply in Australia under Australian conditions. The information in this Brochure is therefore indicative, illustrative and provided only for guidance and should not be relied on. To obtain current and accurate information on a vehicle and any options applicable to Australia, contact your local authorised Mercedes-Benz dealer.



The C-Class Coupé. More style per hour.

The C-Class Coupé embodies the tension between style and urgency. Externally, it is a compellingly attractive, dynamic coupé which expresses a strong sense of forward motion. Inside, it is a place to sit back and relish every corner and twist in the road in an ambience of sportiness and functional perfection. The result is sheer driving enjoyment.

Support is provided by engines equipped with the ECO start/stop function as standard, the sporty set-up of the AGILITY CONTROL suspension with selective damping system, an electronic brake control system and features which set the standard for safety.

Guide to the vehicles shown here:

**2 | Mercedes-Benz C 350
palladium silver metallic**

AMG 7-spoke light-alloy wheels, Bengal red leather, dark longitudinal-grain aluminium trim, AMG sports package

**10 | Mercedes-Benz C 250 CDI
designo diamond white bright**

5-spoke light-alloy wheels in sterling silver, black ARTICO man-made leather, Style package

**14 | Mercedes-Benz C 250 Sport – engineered by AMG
designo platinum magno**

7-twin-spoke light-alloy wheels in high-gloss black with high-sheen finish, ARTICO man-made leather/DINAMICA microfibre in black

The illustrations may include accessories and optional extras which do not form part of the standard specification.

Vision.

20 | Moving innovation

Drive system and chassis.

22 | Diesel engines

23 | Petrol engines

24 | Transmissions

25 | Chassis and suspension

Safety.

26 | Integral safety concept

Comfort.

30 | Multimedia systems

32 | Assistance systems

34 | Seats

Model variant.

36 | C-Class Coupé Sport

AMG.

38 | C 63 AMG Coupé

40 | C 63 AMG technology
and engineering

42 | C 63 AMG Edition 507

Equipment and appointments.

44 | Optional extras

45 | Equipment packages

51 | designo

52 | Upholstery and trim

58 | Wheels

60 | Genuine accessories

62 | Services.

Facts and colours.

64 | Dimensions

64 | Paintwork

65 | Technical data



Two doors, no compromises. The ultimate coupé!

The low silhouette with a long, arrow-shaped bonnet. The upright, louvred radiator grille with a central star, the strong shoulders, short overhangs and a powerfully thrusting tail end. Every centimetre underlines the character of this coupé: built for people who don't like to stand still.



Concise care instructions:
needs asphalt under its tyres daily.







Concerned about the environment? So are we.

Modern motoring calls for an intelligent drive. With this in mind, the C-Class Coupé offers optimised engine technology in four efficient petrol and diesel variants. Additional fuel-saving potential is offered by a standard-fit ECO start/stop function and the optionally available 7G-TRONIC PLUS automatic transmission. Good for the carbon footprint.

→ Page 22–24



Welcome to the Coupé lounge.







Perhaps your first Mercedes.
Certainly not your last.







Just what you need: a sixth sense.

The C-Class Coupé is always a bit further ahead than you think, thanks to numerous safety systems which take account of virtually every eventuality and help defuse hazardous situations. Take the ADAPTIVE BRAKE control system, which can apply the brakes in anticipation of danger. So if the worst comes to the worst, the car can be brought to a stop even more quickly. It's good for all concerned, not just your heart rate.

Lateral dynamite.

In this cockpit you will experience what cornering really means: the C-Class Coupé Sport – engineered by AMG. The specially tuned AMG sports suspension and the more direct steering ensure tangibly greater lateral dynamics. The shortest route between two points now feels like a bend.









S-plosion at the push of a button.

Sport says it all: the touch of a button is all it takes to activate Sport mode – S-Mode for short. The drive system then reacts tangibly more directly. The shift points change. The driving experience is intensified. You will ask yourself why the S-Mode can be switched off at all. The answer is: so that you can switch it back on again.

→ Page 36–37



The sharpest centrifuge of all time.

Every road sooner or later leads to a bend. If it were up to the driver of the C-Class Coupé Sport: preferably sooner. The black ARTICO man-made leather/DINAMICA microfibre AMG sports seats with red contrasting topstitching provide firm support. In addition, the seats are equipped with red safety belts. Further highlights inside include the silver steering wheel paddles, the brushed aluminium trim featuring a dark longitudinal-grain finish and the sports pedals in brushed stainless steel. A tap on the accelerator is all it takes to bring the Coupé's sporting credentials to life.

What makes a car a Mercedes?

Deep-rooted traditions: in our case, it is innovative traditions that run deep. We've gone along previously untravelled roads. Setting milestone after milestone. The first car with a crumple zone, the first ABS, the first diesel car. The first car. And whilst it's nice to look back, we'd much rather look forward.

Mercedes me – welcome to a world that revolves entirely around you. We focus on people. No more so than when we developed a new platform for you to keep in close contact with Mercedes-Benz. With services that are tailored to your needs. “connect me” connects the vehicle to your world of experience, to everything that is important to you. “move me” provides new mobility solutions. And “inspire me” gives you an exclusive insight into the future of mobility. Your gateway to a fascinating world: www.mercedes.me



Mercedes-Benz Intelligent Drive – on the road to accident-free driving. We develop intelligent technologies that actively assist the driver and make driving tangibly easier. Valuable assistance systems are already available in your Mercedes-Benz: they help to maintain the distance to the vehicle in front automatically, brake the car when necessary and warn against imminent rear-end collisions or vehicles in the blind spot. The sensors of the driving assistance and safety systems are linked intelligently. Potential hazardous situations are detected earlier than ever and consequently avoided with increasing regularity. Discover the fascinating world of Mercedes-Benz Intelligent Drive at www.mercedes-benz-intelligent-drive.com

BlueEFFICIENCY – our vision of emission-free driving. Sustainability is a big word. And it's a prime consideration in absolutely everything we do. From minimising the environmental impact of our production operations to alternative drive concepts.

The aims are ambitious, as you can see. But what could be better than seeing these aims achieved whilst on a long drive in a Mercedes?

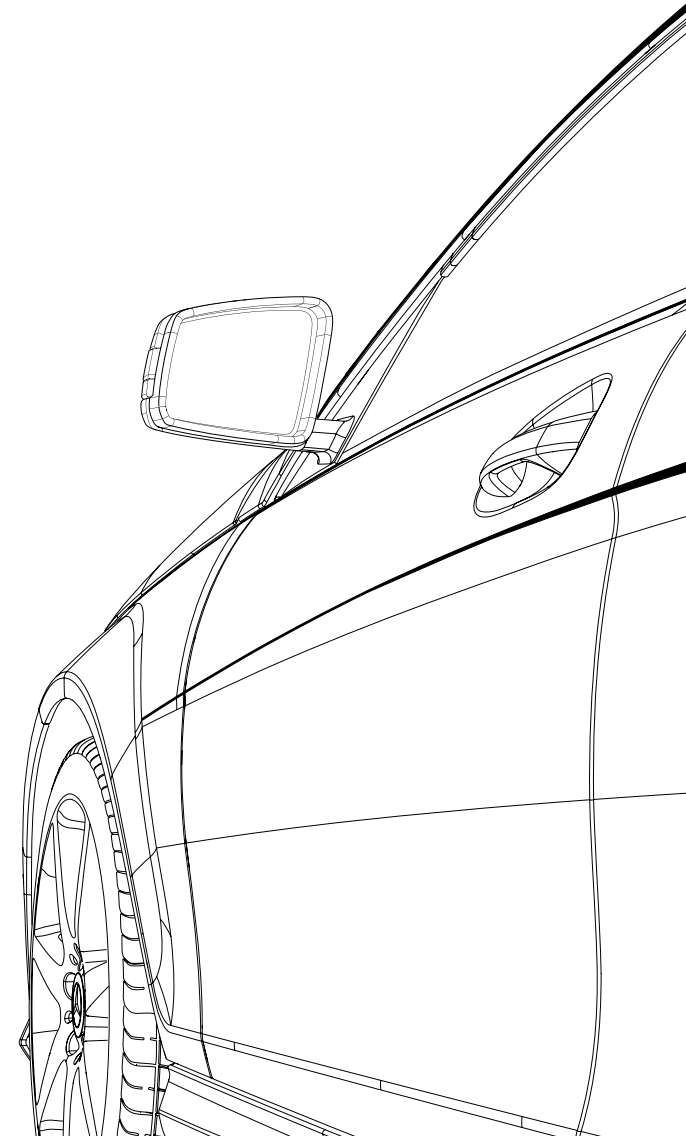

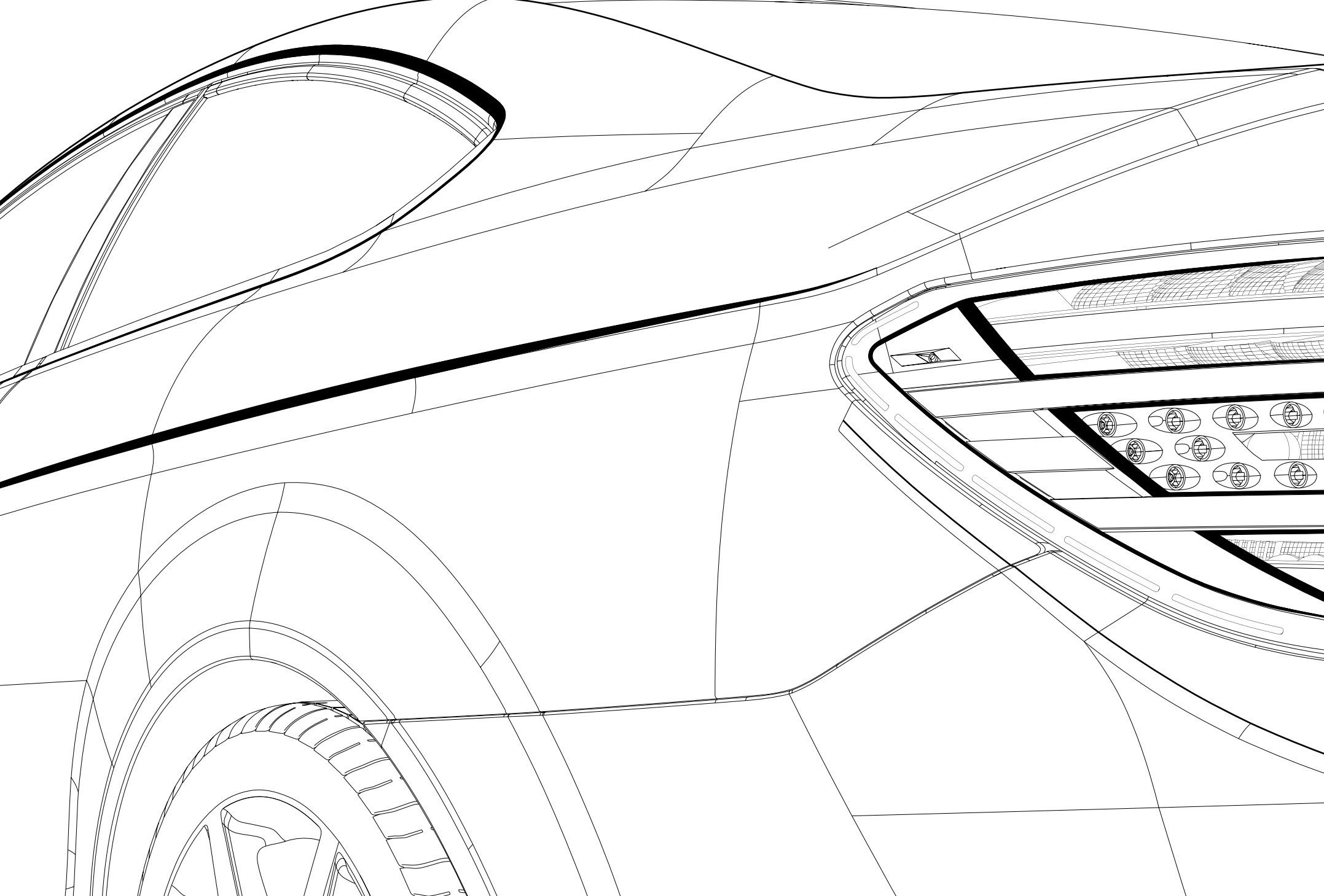

Diesel engines.

The diesel engines for the new C-Class Coupé stand for efficient, refined and powerful driving. They combine higher performance with markedly lower fuel consumption than conventional engines.

4-cylinder engines. The diesel powerplants incorporate a wealth of efficient technology. As a result, their output is up to 20% higher than that of comparable older engines: the C 220 CDI delivers 125 kW (170 hp), the C 250 CDI 150 kW 204 (hp). At the same time, the torque of both engines has been increased by up to 25%, while fuel

consumption and CO₂ emissions are up to 23% lower. Both models meet the requirements of the Euro 5 emissions standard.

One of the reasons behind the impressive performance of the diesel engines is the maximum injection pressure of up to 2000 bar. What's more, the required fuel quantity is metered extremely precisely – a sound basis for efficient and on-demand use of energy.

The diesel engines' good consumption/output ratio is also down to their optimised combustion chamber design, which offers ideal conditions for maximising both clean combustion and energy efficiency. At the same time, the optimised alternator management contributes to lower consumption. A further technology which promotes responsible-minded driving pleasure is the efficiency-enhancing turbocharger. Plus there are two balancer shafts to ensure even smoother running.

Further efficiency measures. All models are equipped as standard with the ECO start/stop function which automatically turns off the engine when waiting at traffic lights or in a tailback. The ECO display available for many models provides feedback about the efficiency of the driving style which can then be adapted accordingly to reduce fuel consumption.

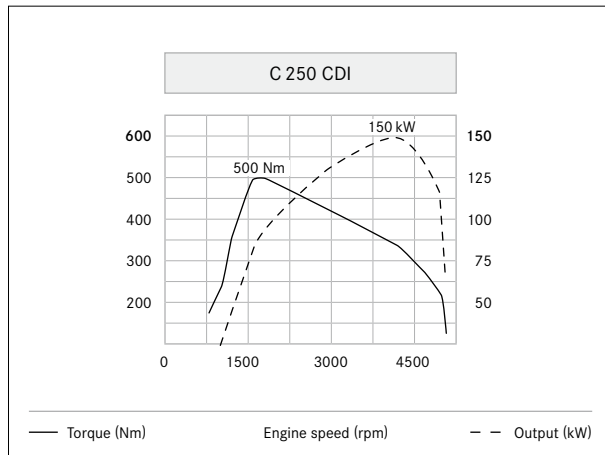

Impressive torque, even at low revs: ideal for spontaneous bursts of speed.



The ECO display provides feedback about the efficiency of the driving style.

Petrol engines.

Agility and efficiency go hand in hand, as demonstrated by the petrol engines. Both the 4-cylinder models and the V6 powerplant combine a high level of refinement with low fuel consumption.

4-cylinder engines. The current generation of 4-cylinder petrol engines pursues one major goal: more output and better acceleration figures in conjunction with lower fuel consumption. This is thanks to the direct injection system with an injection pressure of up to 200 bar, which ensures optimum preparation of the air/fuel mixture and therefore

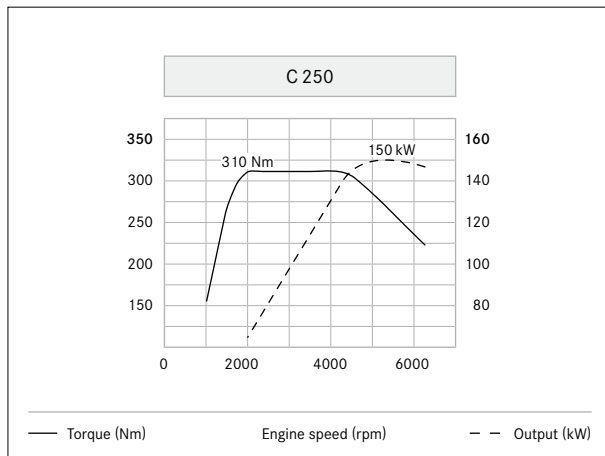

Not just remarkable in terms of performance data. The fuel-consumption figures are impressive, too.

increases the effectiveness of the engine. The engine management also optimises the valve timing through continuously variable camshaft adjustment and piezo-controlled injectors with multi-hole valves. Savings have been achieved when it comes to engine weight, in particular: the cylinder crankcase, for example, is made of aluminium and the crankcase was cast hollow. Further optimisations reduce consumption over and above this. They include ancillaries controlled according to requirements and the electromechanical steering system in the C 180, for example. This only requires energy during the actual process of steering – without any compromises in terms of steering comfort.

Performance potential: the C 180 accelerates from 0 to 100 km/h in just 8.5 seconds and goes on to reach a maximum speed of 225 km/h. The C 200 has a top speed of 237 km/h and completes the sprint from 0 to 100 km/h in just 8.2 seconds. The C 250 has a top speed of 240 km/h and accelerates from 0 to 100 km/h in 7.2 seconds.

6-cylinder engine. Economical, clean and high-torque: the C 350 heralds the arrival of a new generation of technology – drive concepts that are sparing in their use of resources. With combined fuel consumption of 7.0-6.8 l/100 km, the engine attains a maximum output of 225 kW (306 hp) and can accelerate the new C-Class Coupé from 0 to 100 km/h in barely 6.0 seconds. The maximum torque of 370 Nm creates a particularly wide engine speed range, so that impressive reserves of power are available for every driving situation.

Further efficiency measures. Similarly to the diesel engines, all petrol-engine models also feature the ECO start/stop function as standard.

Transmissions.

The two transmissions available for the C-Class Coupé deliver optimum pulling power in every driving situation.

6-speed manual transmission. The 6-speed manual transmission combines sporty and economical driving. The transmission ratio is ideally tailored to the engine output and the particularly exact and short shift throws make each gear change a pure joy. The integrated gear-shift recommendation function, ECO start/stop function and current consumption indicator can also help optimise fuel consumption and reduce emissions. The ECO start/stop function switches off the engine when the vehicle comes to a standstill or is coasting – for example at a traffic light – and switches it back on when the clutch is depressed or the driver steps on the accelerator pedal.

7G-TRONIC PLUS. The efficiency-optimised 7G-TRONIC PLUS automatic transmission is one of the major factors behind the exceptionally high level of driving enjoyment. The seven forward gears allow a constantly optimised rpm level, meaning that fuel consumption can be reduced. The transmission technology also comes into play when the driver wants to accelerate powerfully or experience the full range of the C-Class Coupé's agility. For example, individual gears can be skipped when overtaking or in situations requiring spontaneous acceleration. Furthermore, the transmission modes "E" (Economy) and "S" (Sport) can be selected at the touch of a button.

In conjunction with the optional AMG Sports package or AMG Plus Sports package and the optional Dynamic Handling package with Sport driving mode there is an additional driving mode, "M", for manual shifting via the steering-wheel gearshift paddles. 7G-TRONIC PLUS is available as standard in the C 250 CDI Sport, the C 250, the C 250 Sport and the C 350. For the other models, this transmission is available as an option.



7G-TRONIC PLUS: one of over 18 million automatic transmissions produced in more than 50 years.

Chassis & suspension.

The chassis technology for the C-Class Coupé allows comfort-oriented or sporty driving with supreme agility in almost any situation on the road.

AGILITY CONTROL suspension (standard). The suspension with selective damping system can adjust automatically to the current road conditions and driving style. To do this, a valve automatically reduces the damping force at each wheel when the shocks caused by the road are weaker, thus lowering road roar and tyre vibration. If these shocks are stronger, the system's damping effect is enhanced and can improve the car's driving stability.

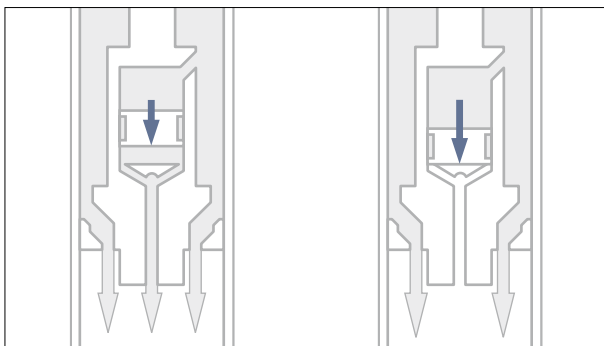

Outstanding agility and a high level of comfort: the AGILITY CONTROL suspension can adapt to any driving style.

Dynamic Handling package with Sport mode (option).

This optional package enhances driving dynamics and driving enjoyment on every trip. There are three transmission modes – Economy, Manual and Sport – and the lateral dynamics can be controlled separately in Sport mode. S mode initially alters the settings of the 7G-TRONIC PLUS automatic transmission and tangibly changes the accelerator characteristics – so the engine is more responsive, which enhances longitudinal dynamics.

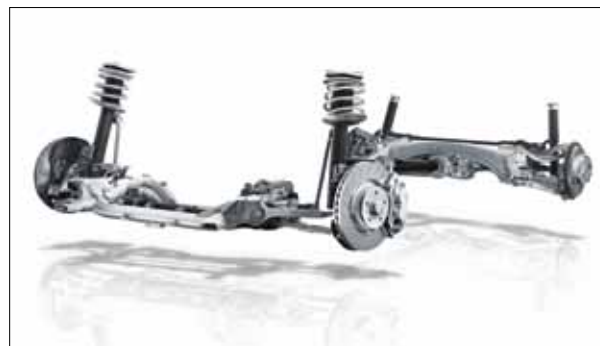

A suspension system lowered by 15 mm is one of the features which complements the Dynamic Handling package.

Furthermore, stiffer suspension settings can be selected, allowing even sportier driving with noticeably enhanced lateral dynamics. Driving enjoyment on fast corners is boosted significantly if the chassis is lowered by 15 mm. With its modified steering response map and a direct ratio, the speed-sensitive sports steering delivers an exceptionally sporty and agile driving feel that is complemented perfectly by a 3-spoke multifunction steering wheel in nappa leather with gearshift paddles (in conjunction with automatic transmission).

Whatever the selected mode, the electronically controlled damping system adjusts to driving and road conditions.

Integral safety concept.

We are driven by our vision of accident-free motoring. With our integral safety concept we are coming closer to achieving this goal – this is a holistic approach which can increase safety in every situation.

As the inventor of the car we feel that we have a special responsibility for road safety. This is why we are the first car manufacturer to have developed an integral safety concept which seamlessly blends measures to enhance active and passive safety. The holistic approach is subdivided into four phases and offers safety solutions for every situation. It includes systems for safe driving which help to avoid risks by warning you and coming to your aid in good time. Our unique PRE-SAFE® system kicks in in the event of danger and activates anticipatory measures for occupant protection. If a collision should still occur in spite of all the preventive measures, further technologies ensure protection as needed. We have also borne in mind the time immediately following an accident and developed solutions which can help prevent worse and facilitate rapid help.

A selection of these technologies for the “Safe driving”, “In the event of danger”, “In an accident” and “After an accident” phases is presented on the pages which follow.

Safe driving: ATTENTION ASSIST (standard). The ATTENTION ASSIST drowsiness detection system warns the driver and recommends a break as soon as it detects signs of tiredness. To this end, it monitors the driver’s behaviour at the wheel. Should the driving behaviour deviate from a previously determined profile, an acoustic and visual warning will be triggered.

Safe driving: Intelligent Light System (option). The system has five settings to improve visibility for you and other road users: the country mode illuminates the edge of the road, the motorway mode the entire width of the road. The extended fog lamp function improves visibility, whilst the active light function and the cornering light function follow the driver’s steering angle.

Safe driving: Adaptive Highbeam Assist (option). Adaptive Highbeam Assist provides the best possible low-beam range, continually optimising this range according to the given traffic situation. When no other road traffic is detected, main beam is enabled. As soon as oncoming traffic is detected, the headlamps are dimmed automatically.

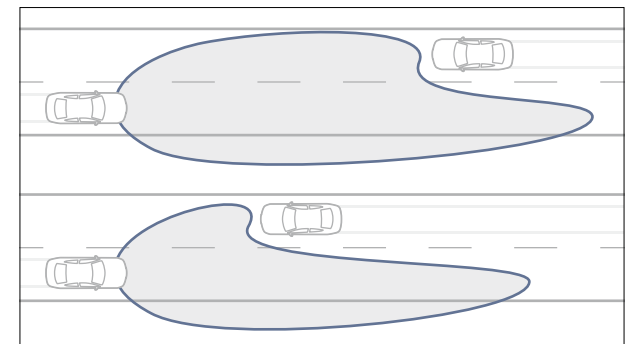

Adaptive Highbeam Assist detects other road users with their lights on and ensures the greatest possible range of vision.

Safe driving: Lane Tracking package (option). Lane Keeping Assist can detect a traffic lane based on the road markings and, if the car is about to leave its lane unintentionally, warn the driver by making the steering wheel vibrate gently. Blind Spot Assist, meanwhile, uses two radar sensors in the rear bumper to monitor the blind spot at speeds above 30 km/h and can warn the driver against dangerous lane changes. Lane Keeping Assist and Blind Spot Assist are also available as separate options.



Blind Spot Assist can warn of potential dangers acoustically and by means of a red warning triangle in the exterior mirror.

Safe driving: Driving Assistance package Plus (option). DISTRONIC PLUS adaptive cruise control can help the driver to maintain a specified distance from the vehicle in front at the push of a button when travelling at speeds of 0 to 200 km/h, also initiating braking when a corresponding need is identified. The radar-based system can brake the vehicle to a standstill. Blind Spot Assist helps the driver when turning or changing lane. A warning triangle lights up in the corresponding exterior mirror when a vehicle is detected in the poorly visible area monitored by the system.

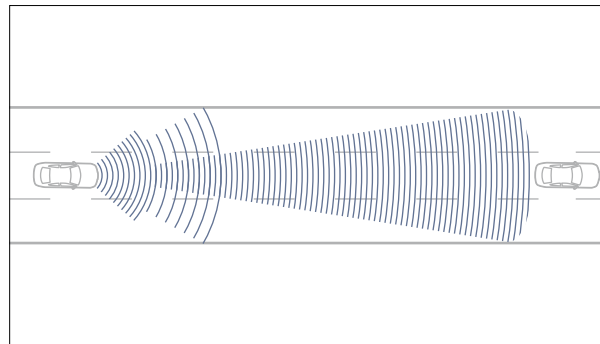

DISTRONIC PLUS can support drivers in automatically keeping their vehicle at a safe distance from the vehicle in front.

If the driver does not react to the warning signals, the system can automatically brake individual wheels to prevent a possible accident. Active Lane Keeping Assist warns the driver by means of a discreet vibration of the steering wheel as soon as he unintentionally drifts across the lane markings which have been detected by the system and threatens to leave the vehicle's current lane. If the driver fails to respond, individual wheels can be braked as appropriate to return the vehicle to its lane. The system recognises contrasts on the road ahead of the vehicle and is thus able to "read" lane markings. It also monitors driving behaviour and the course of the lane, analysing this information for movements which typically indicate that the vehicle is about to leave its lane unintentionally. In this way, the vehicle is able to distinguish reliably between the vehicle leaving its lane intentionally and unintentionally. The Driving Assistance package Plus is rounded off by BAS PLUS brake assist and the PRE-SAFE® Brake – for an assured feeling of safety on every trip.

In the event of danger: PRE-SAFE® Brake and BAS PLUS (part of the optional Driving Assistance package Plus). PRE-SAFE® Brake provides the driver first with a visual warning, then an audible alert if a risk of collision is detected. During this phase, BAS PLUS calculates the brake pressure that is required to prevent a collision. If the braking force applied by the driver is not sufficient, the system automatically increases brake pressure in a way that ensures the remaining braking distance is used to the fullest advantage. This means that the driver of the vehicle behind also has a better chance of avoiding a rear collision.

If the driver fails to respond to the signals, PRE-SAFE® Brake intervenes with autonomous partial braking, giving the driver a tangible warning. At the same time, the PRE-SAFE® system also triggers other protective measures in preparation for a possible collision. Autonomous emergency braking can then be activated if the driver still does not react. This markedly reduces impact speed and accident severity.

In the event of danger: PRE-SAFE® system (option). This preventive occupant protection system is able to identify certain critical driving situations in advance and initiate preventive measures. When an impending risk of an accident is identified, the side windows are closed, the front passenger seat with Memory package is moved to a position which will be more favourable in accident conditions and the front seat belts are automatically tightened. Where fitted, the sliding sunroof will also close.

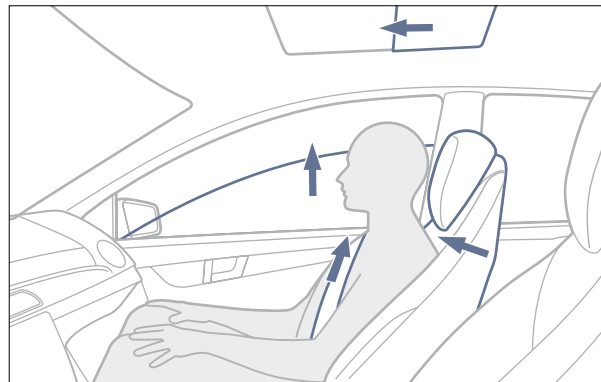

The PRE-SAFE® anticipatory occupant protection system helps to mitigate the consequences of accidents.

In an accident: NECK-PRO head restraints (standard). In the event of a rear impact, the sensor-controlled NECK-PRO head restraints for the front passengers move forward and upward within a matter of milliseconds. They can thus reduce the gap between the head and the head restraint, thereby reducing the risk of injury.

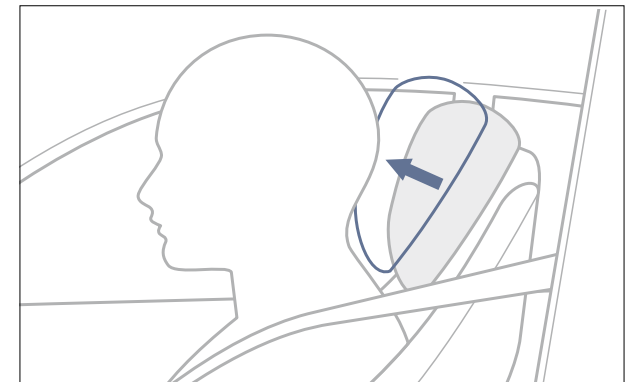

The NECK-PRO head restraints can help to reduce the risk of whiplash in an accident.

In an accident: Retention systems (standard). 3-point seat belts, belt tensioners, belt force limiters and airbags are ideally matched in Mercedes-Benz vehicles to minimise any injuries. The C-Class Coupé is equipped with numerous airbags. In an accident, these can help to reduce the risk of injuries to passengers considerably. The standard scope comprises driver and front passenger airbags, sidebags and pelvisbags in the front, a kneebag for the driver and windowbags. In addition, sidebags for the rear are

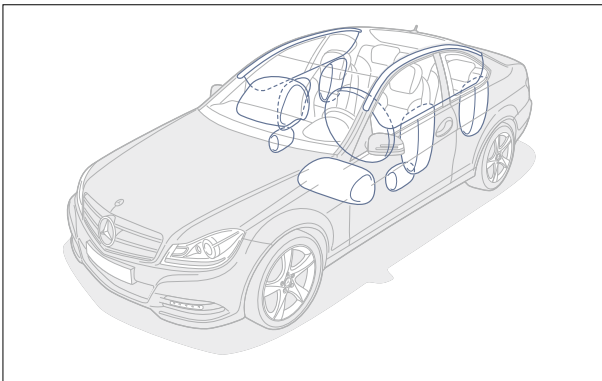

The robust passenger cell with defined crumple zones and the numerous airbags contribute to the exemplary occupant protection.

optionally available. On the crash sensors detecting an accident, the seat belts are automatically tightened instantaneously in order to retain the passengers firmly in their seats – including the outer rear seats as standard. The belt force limiter relaxes the belt according to the given situation, in order to avoid imposing excessive strain on the occupants' chests.

In an accident: Active bonnet (standard). The active bonnet can reduce the risk of injury to pedestrians and cyclists. In the event of an impact, its rear section is raised around five centimetres, thus creating additional deformation space to soften the blow for a pedestrian or cyclist.

After an accident: Mercedes-Benz emergency call system¹ (part of COMAND Online). This system is able to send an automatic emergency call using a working mobile phone connected to the vehicle as soon as the restraint system recognises an accident. At the same time it communicates

GPS positional data and other information to the Mercedes-Benz emergency call centre. A voice connection is then established. The emergency call system can also be triggered manually.

Measures after an accident. In order to mitigate consequential damage and, where necessary, expedite the rescue of the occupants, Mercedes-Benz has developed further measures. These include automatic engine cut-off, for example, or activation of the hazard warning lamps and interior emergency illumination. The central locking also opens automatically, and crash joints between the door and the wing make it easier to open the doors after a frontal impact. Mercedes-Benz also provides multilingual rescue guidelines which emergency services can download online worldwide at www.mercedes-benz.de/rettungsleitfaden. As you can see, Mercedes-Benz offers well thought-out safety whatever the situation.

¹ Available over the entire operating life of the vehicle in 19 European countries.

Multimedia systems.

To drive in style, you also need quality entertainment and helpful navigation. Cue our outstanding entertainment electronics and excellent navigation systems.

COMAND Online (option). The multimedia system boasts a high-resolution 17.8-cm colour display. The system's functions include a radio, speed-sensitive volume control, the Music Register with a 10 GB hard disc and hard-disc navigation. What's more, it also comes with free European map data updates for three years following initial registration. The best in entertainment is provided courtesy of the DVD player, which can play CDs and MP3 files as well as

video and audio DVDs. The online function facilitates access to the internet and various Mercedes-Benz mobile services via a web-enabled mobile phone. This means that you can surf the internet freely when at a standstill and you can use various apps during the journey, such as weather, Google Street View, Facebook or car park search. A USB connection, an Aux-in socket, a slot for SD memory cards and a Bluetooth® interface allow connection to exter-

nal data storage media and a mobile phone. The system is operated using the central Controller and the buttons on the 3-spoke multifunction steering wheel. The LINGUATRONIC system allows you to control COMAND Online using voice commands.

Live Traffic Information¹ (part of COMAND Online). This service allows the reception of up-to-date and precise traffic information in real time for optimised dynamic route guidance and a more accurate estimated time of arrival. The data are transferred via a communications module that uses an integrated SIM card with data roaming to provide the connection to the internet.



As well as displaying navigation data in high resolution, the large TFT display also optimises the display of web and multimedia content.

¹ 3 years of free use, available in 12 countries.

Harman Kardon® Logic 7® surround sound system (option). The 450 W surround sound system provides for a delightful audio experience on every trip. Twelve high-performance speakers and the Logic 7® multi-channel surround sound technology conjure up a three-dimensional sound impression. The automatic volume control adapts the sound in line with the car's current speed.



All you need for pure musical enjoyment: the Harman Kardon® Logic 7® surround sound system.

Audio 20 with Bluetooth® interface and USB connection (standard). Includes a radio function as well as a CD player with MP3 capability. The system is controlled via the multifunction steering wheel and the TFT display with a screen diagonal of 14.7 cm. A mobile phone can be linked via Bluetooth® for hands-free operation. There are also numerous interfaces available.



Audio 20 with eight precisely tuned speakers for delivering outstanding sound.

Becker® MAP PILOT (option). The Becker® MAP PILOT takes you safely to your destination and has everything you look for in a sophisticated navigation system. It is installed in the glove compartment, is simple to operate via the Controller and also the Audio 20 CD's display, and it can be further individualised by downloading up-to-date map data and additional functions.

Assistance systems.

The C-Class Coupé is designed to make sure you are relaxed on the way to your destination. That is why it offers systems that can support and assist you in a wide range of traffic situations, for example when parking, on cross-country journeys with speed limits or in challenging driving situations.



Speed Limit Assist shows the driver the current speed limit.

Speed Limit Assist (included with the optional COMAND Online system). Speed Limit Assist can detect speed-limit signs and display them as symbols on the instrument cluster and in COMAND Online on the navigation screen. They remain displayed there until the speed restriction is lifted or changed. To this end, a windscreen-mounted camera monitors the area in front of the car on a permanent basis. The camera can filter out round traffic signs, be they speed-limit signs at the side of the road or on a gantry above the road. To detect the signs, the system also draws on the data stored in the navigation system's digital map, thus also enabling it to take account of the vehicle entering or leaving urban areas. Speed Limit Assist is especially helpful on routes with variable speed limits or road works.

Reversing camera (option). The reversing camera with wide-angle lens monitors the area directly behind the vehicle and sends the images to the COMAND display. It is activated when reverse gear is engaged, thus enhancing safety when backing into a parking space. The reversing camera is only available in conjunction with COMAND Online.



The reversing camera makes it easier to perform many manoeuvres when space is tight.

PARKTRONIC incl. Parking Guidance (option). PARKTRONIC can warn the driver automatically if space in front of or behind the car becomes tight when parking or manoeuvring. The system operates on the echo sounder principle. Sensors on the front and rear bumpers emit ultrasound signals which are then reflected by other vehicles or obstacles. A microcomputer calculates the current distance and informs the driver by means of displays in the instrument cluster and audible signals. Parking damage can be avoided in this way. Parking Guidance can help the driver



Parking Guidance indicates the appropriate steering angle and signals to the driver when the steering wheel requires to be turned.

when looking for a parking space and also when parking: ultrasonic sensors in the side front bumper can measure the length of parking spaces parallel to the car automatically if the car drives past at a speed of 35 km/h or less. Parking Guidance starts once a suitable space has been found and reverse gear has been engaged. It provides the driver with visible and audible instructions regarding the correct steering angle as well as the turn-in and turn-back points on the instrument cluster. If the car is not straight after the first reversing move, the system also helps the driver with the required manoeuvres.

Seats.

The new C-Class Coupé is fitted with specially designed coupé seats including integrated head restraints and individual rear seats. As well as being style-defining, the seat design offers the greatest possible support, even during sporty driving, as well as perfect ergonomics.



The standard-fit coupé seats are ergonomically designed. You can tell that they are made for a highly agile car: the C-Class Coupé.

Coupé seats. Ergonomic coupé seats await driver and front passenger. Their upholstery is covered in a combination of ARTICO man-made leather/fabric; upholstery is optionally available in ARTICO man-made leather or genuine leather. Both the seat cushion height and the backrest inclination are electrically adjustable at the push of a button. Heated or climatized seats are optionally available.

Individual rear seats with integral head restraints. The lounge-like character of the interior is also reflected in the ergonomic, individual design of the rear seats with integral head restraints. An asymmetrically split and folding rear seat backrest is included as standard (except in the C 180). Convenience is further enhanced by the manually operated EASY-ENTRY system, which makes it easier to get into and out of the car.



Sheer comfort: it's easy for rear passengers to get into the car thanks to the EASY-ENTRY system, which shifts the front seats fully forwards in one simple move.

Memory package (option). This package extends the range of seat settings and, if several people drive the car, ensures that each driver can adopt their preferred sitting position quickly by calling up their own pre-programmed settings – for the driver's seat, steering column and exterior mirrors – at the touch of a button. In addition to this, the Memory package includes a 4-way lumbar support for both the front seats.



The ergonomic driver's seat moves into the pre-programmed desired position at the touch of a button.



The Sport models feature black-painted exterior mirrors and a radiator grille with twin louvres in high-gloss black.



The sports exhaust system with active sound shaping for a race-track atmosphere.

C-Class Coupé Sport.

The C-Class Coupé Sport – engineered by AMG – turns every bend into a special experience. For the best cornering and lateral dynamics in its class, the vehicle boasts an exclusively tuned AMG sports suspension. Acoustically, the rich sound of the sports exhaust system provides the backdrop for the powerful propulsion. The specially configured Sport mode makes the engine react tangibly more directly, as it changes the shift points and shortens the response times with a double-declutching function. And when braking with the sports braking system the transmission actively shifts down. There is additional visual highlighting of what facilitates more sportiness and dynamism in technical terms: the spoiler lip, AMG Styling and AMG light-alloy wheels clearly show what the vehicle demonstrates on every journey: sporting perfection.

The C-Class Coupé Sport includes the AMG Plus Sports package and is rounded off by the following technical and design components:



AMG 7-twin-spoke light-alloy wheels, painted in high-gloss black with a high-shine finish.

C-Class Coupé Sport

AMG 7-twin-spoke light-alloy wheels, painted in high-gloss black with a high-shine finish

AMG lowered sports suspension with set-up optimised for lateral dynamics

Exterior mirrors painted black

Radiator grille featuring twin louvres in high-gloss black with chrome trim

Sports exhaust system – including active sound shaping for the C 250 CDI Sport model

Sports braking system with larger brake discs, including perforated front brake discs, callipers with “Mercedes-Benz” lettering

“Sport” label on the side wings

Sports-tuned engine and transmission in S/M mode

- More agile accelerator pedal characteristics with more direct response

- Shorter shift times

- Gear changes with double-declutching function

- Active downshifting when braking

Speed-sensitive sports steering with more direct ratio



The AMG sports seats in ARTICO man-made leather/DINAMICA microfibre upholstery provide optimum support.



C 63 AMG Coupé.

The C 63 AMG is the epitome of an expressive coupé. The AMG front apron, the AMG radiator grille with one chrome louvre, the unique AMG bonnet with powerdomes, the unique AMG daytime running lamps, the side sill panels and the rear apron with inset diffuser are just some of the features that demonstrate its commitment to performance. The AMG sports exhaust with two chromed twin tailpipes likewise emphasises the high-performance credentials of the coupé and shows unequivocally that this particular Mercedes-Benz is powered by an AMG drive system. The exterior is completed to perfection by AMG light-alloy wheels, further underlining the fact that this is a highly responsive car built for motoring enjoyment. Further exterior features are listed below.



Exterior

AMG spoiler lip on the boot lid

AMG high-performance braking system with 360 x 36 mm front brake discs and 330 x 26 mm rear brake discs

AMG 5-twin-spoke light-alloy wheels, painted in titanium grey with a high-sheen finish, with 235/40 R 18 front tyres and 255/35 R 18 rear tyres

AMG bodystyling, comprising front apron with side air outlets and cross strut in high-gloss black, side sill panels and diffuser-look rear apron

Distinctive, flared front wings with "6.3 AMG" lettering

Tail lights with LED technology



Powerful outside, stylish inside: the interior of the new C 63 AMG follows a concept which has been thought through down to the finest details. The AMG door sill panels alone show, when opening the doors, that this vehicle is something special. Passengers travel in AMG sports seats which are upholstered either in a black ARTICO man-made leather/ DINAMICA combination or optionally in designo leather (single- or two-tone). The AMG Performance steering wheel features a flattened top and bottom rim and aluminium shift paddles. The AMG instrument cluster with colour display and AMG Start-up indicator is positioned for maximum ergonomic effect. The black headlining and the AMG sports pedals round off the sporty setting.

→ www.mercedes-amg.com



Interior

AMG door sill panels in brushed stainless steel

AMG instrument cluster with 11.4 cm high-resolution colour display, incl. RACETIMER and AMG Start-up indicator

AMG Performance sports steering wheel in nappa leather, with flattened top and bottom sections as well as silver-coloured aluminium shift paddles

AMG speed-sensitive sports steering

AMG sports seats in black ARTICO man-made leather/ DINAMICA microfibre
ATTENTION ASSIST system

Rotary switch to select four transmission modes and Race Start function

Brushed stainless-steel sports pedals with rubber studs

High-gloss black piano-lacquer-look trim

C 63 AMG technology.

The AMG 6.3-litre V8 engine and the AMG SPEEDSHIFT MCT 7-speed sports transmission offer an emotional driving feel and driving dynamics at the highest level. But when it comes to choosing a sporty or comfort-oriented driving style, the driver always has the final say in the C-Class Coupé. → www.mercedes-amg.com

AMG 6.3-litre V8 engine. A high-revving naturally aspirated engine incorporating thoroughbred motorsport technology: the vertical arrangement of the intake and exhaust ducts and the magnesium variable-intake manifold with two integral throttle valves ensure optimum charging of the eight cylinders. Further high-tech features include variable camshaft adjustment, the four-valve-per-cylinder design, the stiff aluminium crankcase and the low-friction TWAS (twin-wire-arc-spraying) coating used for the cylinder walls. The V8 powerplant generates 336 kW (457 hp) at 6800 rpm, delivering impressive pulling power and maximum torque of 600 Nm at 5000 rpm. Ideal ingredients for powerful acceleration in every engine speed range, as the driver always has over 500 Nm on tap between 2000 and 6250 rpm.

AMG sports suspension. Superlative driving dynamics come courtesy of the AMG sports suspension with AMG 5-twin-spoke light-alloy wheels fitted with 235/40 R 18 front tyres and 255/35 R 18 rear tyres. The specially designed three-link front suspension with a wider track, the AMG speed-sensitive sports steering and the three-stage ESP® provide for a thrilling driving experience. The AMG speed-sensitive sports steering has an even more direct ratio and therefore offers greater steering precision at high cornering speeds. The AMG sports suspension's stiff springs, gas-pressure shock absorbers and unique axle kinematics provide optimum agility at the driving limits as well as outstanding lateral dynamics. The AMG sports suspension therefore combines driving dynamics at the highest level with hallmark Mercedes long-distance comfort – and thus displays the characteristic attributes of a true AMG. The Electronic Stability Program ESP® has been specially

adapted in line with the high level of driving dynamics, as it allows the driver to select the level of assistance provided by the dynamic handling control system by choosing one of three different control settings: ON, OFF and SPORT HANDLING MODE. The activated setting is shown on the AMG instrument cluster's central display. The AMG high-performance braking system featuring large, internally ventilated and perforated brake discs ensures outstanding levels of deceleration. Perfect brake control, extremely short stopping distances and excellent fade resistance are the defining features of the AMG high-performance braking system.

Also available is the optional AMG Performance suspension. With its sportier spring and damper tuning this suspension responds even more quickly and more directly to meet the very highest dynamic handling requirements.

AMG SPEEDSHIFT MCT 7-speed sports transmission.

With AMG aluminium steering wheel gearshift paddles, four driving programmes and the Race-Start function, the 7-speed automatic transmission makes for enhanced driving dynamics and high efficiency. The “S” (Sport), “S+” (Sport Plus), “C” (Comfort) and “M” (Manual) modes each have different gear-change characteristics and speeds: Gear changes in “S” and “S+” modes are around 20 and 40 per cent swifter than in “C” mode respectively – while in “M” mode gear changes take just 100 milliseconds, making them some 50 percent faster. A push of a button activates the desired mode: distinctly sporty or more comfort-oriented. There is an automatic double-declutching function when downshifting, which provides an emotional sound experience as well as reducing power-off effects. This function has a positive effect when braking on the approach to bends in particular.



The AMG SPEEDSHIFT MCT 7-speed sports transmission offers customised modes for maximum driving pleasure.



Motor-racing technology gives the AMG 6.3-litre V8 engine maximum agility.





C 63 AMG Edition 507.

How can the C 63 AMG Coupé's superlative sportiness be topped? The Edition 507 provides the answer. On this special model, the power of the AMG 6.3-litre V8 engine is boosted by 37 kW (50 hp) to 373 kW (507 hp), with an accompanying increase in torque to 610 Nm. The standard-specification Driver's Package additionally allows a top speed of 280 km/h. This dynamism is underscored by the red-painted callipers of the AMG high-performance composite braking system and the AMG bonnet, for example. The expressive exterior is accompanied by an equally exclusive interior: the AMG instrument cluster with red applications and the AMG Performance steering wheel in black Alcantara® ensure that the driver keeps a firm grip on the Edition 507's emphatically sporty character at all times.

Exterior

AMG naturally aspirated 6.3-litre V8 engine rated at 373 kW (507 hp)

AMG high-performance composite brake system with brake callipers painted red

AMG bonnet with air outlets in high-gloss black

AMG cross-spoke forged wheels, painted in titanium grey or matt black, with 235/35 R 19 tyres at the front and 255/30 R 19 tyres at the rear

Exclusive special paint finish in designo graphite magno (optional)

Interior

AMG Performance steering wheel entirely in black Alcantara®, with light-tone contrasting topstitching and 12 o'clock marker

Upholstery in a choice of designo porcelain leather/black DINAMICA microfibre or designo black leather/black DINAMICA microfibre

High-gloss piano-lacquer-look trim

Optional extras | Selection.



Heat-insulating tinted rear window and rear side windows.



Panoramic sliding sunroof.



Blind Spot Assist monitors the blind spot and is able to warn of dangerous lane-changing manoeuvres.



KEYLESS-GO drive authorisation system.



Intelligent Light System.



Mirror package.



COMAND Online multimedia system with Live Traffic Information.



Media Interface.



Exterior Sports package.

The Exterior Sports package adds to the already sporty appearance of the C-Class Coupé. Fitted with 18-inch 5-spoke alloy wheels and sports suspension, it transfers yet more agility and dynamism to the road. The striking-looking tailpipe trim and perforated front brake discs and callipers with “Mercedes-Benz” lettering round off the powerful appearance.



Exterior

Perforated front brake discs, brake callipers with “Mercedes-Benz” lettering

Tailpipe trim in polished stainless steel

5-spoke light-alloy wheels in sterling silver with 225/40 R 18 front tyres and 255/35 R 18 rear tyres

Lowered sports suspension

Speed-sensitive sports steering

Interior

Steering-wheel gearshift paddles in conjunction with 7G-TRONIC PLUS



AMG Sports package.

The optionally available AMG Sports package lends the C-Class Coupé an even more dynamic and athletic appearance as well as enhancing its sporty agility. On the outside, it highlights the coupé's visible forwards thrust with AMG 7-spoke light-alloy wheels and AMG bodystyling, including front and rear aprons as well as side sill panels. The AMG Sports package also includes sports suspension and speed-sensitive sports steering to emphasise the car's effortlessly superior agility.



Exterior

AMG 7-spoke alloy wheels with 225/40 R 18 tyres at the front and 255/35 R 18 tyres at the rear

AMG bodystyling, comprising front apron, side sill panels and rear apron

Perforated front brake discs, brake callipers with "Mercedes-Benz" lettering

Tailpipe trim in polished stainless steel

Lowered sports suspension

Speed-sensitive sports steering



The unique features of the optionally available AMG Sports package lend the interior of the C-Class Coupé extra dynamic touches: the 3-spoke multifunction sports steering wheel with a flattened bottom section allows the driver to change gear using steering wheel shift paddles (only in conjunction with automatic transmission), while the speed-sensitive sports steering enhances the car's sporty handling. The headlining is finished in black fabric. A generously sized instrument cluster with an 11.4 cm colour display and ATTENTION ASSIST catches the eye without distracting the driver's attention from the road. The sporty interior is rounded off perfectly by aluminium trim, brushed stainless-steel sports pedals and AMG floor mats.



Interior

3-spoke multifunction sports steering wheel with flattened bottom section and 12 buttons, in nappa leather, perforated in the grip area

ATTENTION ASSIST system

Floor mats in black with "AMG" lettering

Headlining in black

Instrument cluster with 11.4 cm high-resolution colour display

Steering-wheel gearshift paddles (only with automatic transmission)

Brushed stainless-steel sports pedals with rubber studs

Dark longitudinal-grain aluminium trim



AMG Plus Sports package.

The dynamic lines of the C-Class become even more intensive with the AMG Plus Sports package. This brings out the sporty essence of the model by applying the inimitable AMG treatment in numerous areas. In specific terms this means: AMG bodystyling with front and rear aprons as well as side sill panels, an AMG spoiler lip in the vehicle colour on the boot lid and exclusive AMG 7-twin-spoke light-alloy wheels. The systematic application of the AMG treatment also extends to the details: perforated front brake discs, brake callipers with “Mercedes-Benz” lettering and polished stainless-steel tailpipe embellishers. But it is not just the vehicle’s looks that are enhanced. The speed-sensitive sports steering and sports suspension ensure that the driving dynamics deliver all that the appearance promises.

Exterior

AMG spoiler lip on the boot lid

AMG 7-twin-spoke light-alloy wheels, painted in high-gloss black with a high-sheen finish

AMG bodystyling comprising front apron, side sill panels and rear apron

Brake callipers with “Mercedes-Benz” lettering, perforated front brake discs

Tailpipe trim in polished stainless steel

Lowered sports suspension

Speed-sensitive sports steering



The sporty theme continues inside the vehicle: red topstitching on the AMG sports seats and red designo seat belts are complemented by silver-effect shift paddles on the 3-spoke multifunction sports steering wheel. Aluminium trim, black floor mats with “AMG” lettering and a red surround complete the interior, along with the brushed stainless-steel sports pedals. Together, these features add a distinctly sporty dimension to every trip – even the daily commute.



Interior

3-spoke multifunction sports steering wheel with flattened bottom section and twelve buttons, in nappa leather with red contrasting topstitching, perforated in the grip area

AMG floor mats in black with red surround

AMG sports seats with integral head restraints and single rear seats

Armrest in the centre console, door centre panels and selector lever gaiter with contrasting red topstitching

ATTENTION ASSIST system

designo seat belts in red (can be deselected in favour of black seat belts)

Headlining in black

Instrument cluster with 11.4 cm high-resolution colour display

Steering-wheel gearshift paddles in silver (only with automatic transmission)

Upholstery in ARTICO man-made leather/DINAMICA microfibre in black or in black leather (option)

Brushed stainless-steel sports pedals with rubber studs (including foot-operated parking brake)

Dark longitudinal-grain aluminium trim

Style package.

The Style package further emphasises the sporty and individual interior style of the C-Class Coupé.

The Style package comprises a number of high-quality, harmoniously combined details. The upholstery in black ARTICO man-made leather with contrasting porcelain-coloured topstitching catches the eye straight away.



Handcrafted perfection: the Style package individualises the interior of the C-Class Coupé.

The 3-spoke multifunction sports steering wheel with twelve buttons is trimmed in leather with a two-tone look, the lower section being finished in porcelain-coloured leather. The surface is perforated so that it is even easier to grip. This style is consistently matched by the trim, which is also in a porcelain colour but with a piano-lacquer look.



All the details combine to paint an impressive overall picture: the porcelain-coloured trim shines with a piano-lacquer look.

The armrests, the door panelling, the shift/selector lever gaiter and the centre console are accentuated by contrasting topstitching in a porcelain colour, while the floor mats have porcelain-coloured edging.



Gearshift gaiter with porcelain-coloured contrasting topstitching.

designo.

The designo range allows you to design the C-Class Coupé to an even higher standard and to your own taste. → www.mercedes-benz.com/designo

The wide range of exclusive designo appointments allows you to personalise an already exceptional vehicle. Single-tone appointments including seats and armrests in designo leather and leather-trimmed door centre panels featuring a hallmark designo look create a high-quality, exclusive atmosphere, whether you choose the designo leather in sand, black, porcelain or classic red. And should you wish to emphasise your coupé's individuality even more, designo offers plenty of further possibilities. An optional two-tone designo steering wheel offers the perfect complement to this exclusive designo interior.

The two-tone appointments in designo leather highlight the coupé's sporty, dynamic side. There is a choice of combinations available for the designo leather: sand/black, porcelain/black or classic red/black. As in all Mercedes-Benz models, the metal badge in the backrest is proof of meticulous material selection, exceptional quality, careful craftsmanship and individuality at the highest level. The interior is completed by the extended appointments in designo black leather comprising a leather finish for the upper section of the dashboard.



Upholstery and trim.



The standard-fit seat upholstery in black ARTICO man-made leather/fabric provides the perfect finish to the Coupé's seats. The 3-spoke multifunction steering wheel comes in nappa leather. The roof is lined with alpaca grey fabric; the A-, B- and C-pillars are also in alpaca grey. Dashboard, load compartment cover and door panelling are black. Piano-lacquer trim in black tastefully rounds off the interior design. The trim for the dashboard, centre console and doors is also optionally available in aluminium with dark longitudinal grain or matt brown ash.



black

401 ARTICO man-made leather/fabric

Trim

H80 High-gloss black piano-lacquer look

739 Dark longitudinal-grain aluminium¹

H06 Matt brown ash wood¹

¹ Optional extra.



The seat upholstery in ARTICO man-made leather/fabric in alpaca grey, included as standard, adds the perfect finishing touches to the Coupé's seats. The 3-spoke multifunction steering wheel is trimmed in nappa leather, while the roof lining is finished in alpaca grey fabric. The A-, B- and C-pillars and the door panelling are likewise in alpaca grey. The "split" dashboard is finished in black and alpaca grey, while the load compartment cover is black. A black piano-lacquer-look trim tastefully rounds off the interior design. The trim for the dashboard, centre console and doors is also optionally available in aluminium with dark longitudinal grain or matt brown ash wood.

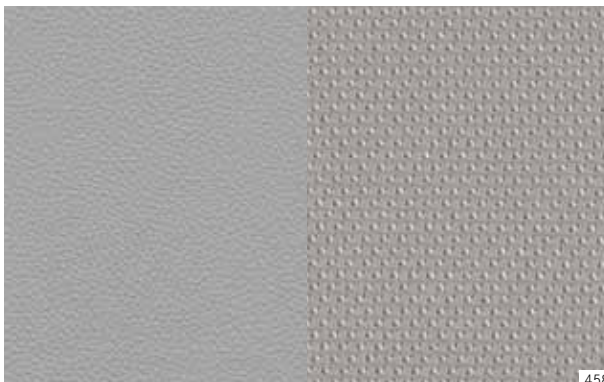

458



H80



739



H06

alpaca grey

458 ARTICO man-made leather/fabric

Trim

H80 High-gloss black piano-lacquer look

739 Dark longitudinal-grain aluminium¹

H06 Matt brown ash wood¹

¹ Optional extra.



At the heart of the optional black colour scheme are the seats in a choice of black ARTICO man-made leather or black leather with alpaca grey topstitching. The 3-spoke multifunction steering wheel is trimmed in black nappa leather. The door panelling also comes in black, while the headlining is finished in black fabric. The A-, B- and C-pillars, the dashboard and the load compartment cover are likewise in black. A dark aluminium trim tastefully rounds off the interior design. The trim for the dashboard, centre console and doors is also optionally available in a high-gloss black piano-lacquer look or in matt brown ash wood.



black

111 ARTICO man-made leather¹

211 Leather¹

Trim

739 Dark longitudinal-grain aluminium trim

H80 High-gloss black piano-lacquer look¹

H06 Matt brown ash wood¹

¹ Optional extra.



At the heart of the optional alpaca grey colour scheme are the seats in a choice of ARTICO man-made leather or leather in alpaca grey with dark alpaca grey topstitching. The 3-spoke multifunction steering wheel is trimmed in black nappa leather. The door panelling is kept in alpaca grey, while the load compartment cover is in black. The headlining is finished in black fabric, while the A-, B- and C-pillars are likewise in black. The “split” dashboard is finished in black and alpaca grey. A dark aluminium trim tastefully rounds off the interior design. The trim for the dashboard, centre console and doors is also optionally available in a high-gloss black piano-lacquer look or matt brown ash wood instead of aluminium.

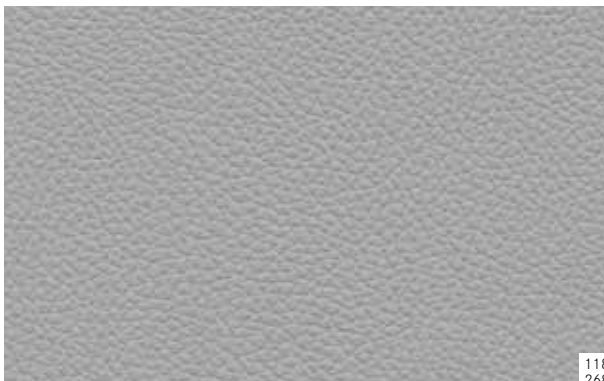

118
268



739



H80



H06

alpaca grey

118 ARTICO man-made leather¹

268 Leather¹

Trim

739 Dark longitudinal-grain aluminium trim

H80 High-gloss black piano-lacquer look¹

H06 Matt brown ash wood¹

¹ Optional extra.



At the heart of the optional saharabeige colour scheme are the seats in saharabeige leather with topstitching in the same colour. The 3-spoke multifunction steering wheel is trimmed in black nappa leather. The door panelling comes in saharabeige, while the roof lining is finished in black fabric. The A-, B- and C-pillars, the dashboard and the load compartment cover are likewise in black. A dark aluminium trim tastefully rounds off the exclusive interior design. The trim for the dashboard, centre console and doors is also optionally available in a high-gloss black piano-lacquer look or in matt brown ash wood.



215



739

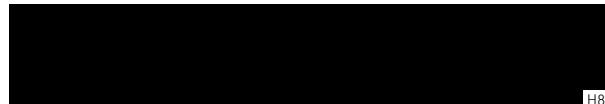

H80



H06

saharabeige

215 Leather¹

Trim

739 Dark longitudinal-grain aluminium trim

H80 High-gloss black piano-lacquer look¹H06 Matt brown ash wood¹

¹ Optional extra.



At the heart of the optional Bengal red colour scheme are the seats in Bengal red leather with black topstitching. The 3-spoke multifunction steering wheel is trimmed in black nappa leather. The door panelling comes in Bengal red, while the headlining is finished in black fabric. The A-, B- and C-pillars, the dashboard and the load compartment cover are likewise in black. A dark aluminium trim tastefully rounds off the interior design. The trim for the dashboard, centre console and doors is also optionally available in a high-gloss black piano-lacquer look or in matt brown ash wood.



267



739

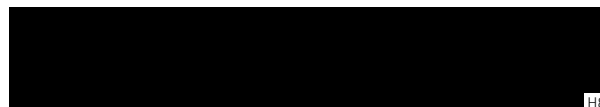

H80



H06

Bengal red
267 Leather ¹
Trim
739 Dark longitudinal-grain aluminium trim
H80 High-gloss black piano-lacquer look ¹
H06 Matt brown ash wood ¹

¹ Optional extra.

Wheels.



10-spoke light-alloy wheels with 245/45 R 17 tyres (standard for C 200, C 250 CDI, C 250 and C 350, Code 25R).



7-spoke light-alloy wheels, painted in high-gloss black and with a high-shine finish, with 225/45 R 17 front tyres and 245/40 R 17 rear tyres, (optional, Code 74R).



7-spoke AMG light-alloy wheels with 225/40 R 18 front tyres and 255/35 R 18 rear tyres (standard wheels for AMG Sports package, Code 782).



5-spoke light-alloy wheels, painted in sterling silver, with 225/40 R 18 front and 255/35 R 18 rear tyres, (optional, Code R36).



5-twin-spoke light-alloy wheels with 225/45 R 17 front tyres and 245/40 R 17 rear tyres (optional, Code R95).



Multi-spoke light-alloy wheels with 225/45 R 17 front tyres and 245/40 R 17 rear tyres (optional, Code 56R).



7-spoke AMG light-alloy wheels, painted in high-gloss black with a high-shine finish, with 225/40 R 18 front tyres and 255/35 R 18 rear tyres, (optional for AMG Sports package AMG Plus Sports package and Sport models, Code 607).



7-twin-spoke AMG light-alloy wheels, painted in high-gloss black with a high-sheen finish, with 225/40 R 18 front tyres and 255/35 R 18 rear tyres, (standard for AMG Plus Sports package and Sport models, Code 760).



5-twin-spoke AMG light-alloy wheels with 225/40 R 18 front tyres and 255/35 R 18 rear tyres (optional, Code 786).



5-spoke AMG light-alloy wheels, painted titanium grey with a high-sheen finish, with 235/40 R 18 front tyres and 255/35 R 18 rear tyres (optional for C 63 AMG, Code 790).



Multi-spoke AMG light-alloy wheels, painted titanium grey with a high-sheen finish, with 235/35 R 19 front tyres and 255/30 R 19 rear tyres (optional for C 63 AMG, Code 788).



7-spoke AMG light-alloy wheels, painted in high-gloss black and with a high-sheen rim flange, with 225/40 R 18 front tyres and 255/35 R 18 rear tyres, (optional for all Sports packages and Sport models, Code 661).



5-twin-spoke AMG light-alloy wheels, painted titanium grey with a high-sheen finish, with 235/40 R 18 front tyres and 255/35 R 18 rear tyres (standard for C 63 AMG, Code 795).



5-spoke AMG light-alloy wheels, painted in matt black with a high-sheen finish, with 235/40 R 18 front tyres and 255/35 R 18 rear tyres (optional for C 63 AMG, Code 609).



Multi-spoke AMG light-alloy wheels, painted in matt black, rim flange with a high-sheen rim flange, with 235/35 R 19 front tyres and 255/30 R 19 rear tyres (optional for C 63 AMG, Code 797).



Genuine accessories.

The C-Class Coupé is a special car. The extensive range of Mercedes-Benz genuine accessories enables you to add further high-quality individuality.

→ www.mercedes-benz-accessories.com

With genuine accessories from Mercedes-Benz, the C-Class Coupé can be made to reflect its owner's personal lifestyle. Those who like to travel with lots of luggage or sports equipment can add further stowage space by opting for the reliable and flexible carrier system and a 450 roof box which is easy to load and unload. The roof box is available in a choice of three sizes: either approx. 450 litres or 400 litres or as a sports box with a capacity of around 330 litres. All boxes can be opened on both sides. Optional extras include a luggage set and a ski rack attachment.

A car as individual as the C-Class Coupé greets you every time you get in and out: with white-illuminated "Mercedes-Benz" lettering on the polished stainless-steel door sill panels.

Thanks to their distinctive styling, the high-end-design light-alloy wheels further emphasise the individual aura of the C-Class Coupé. These light-alloy wheels are available in a choice of sizes and designs, for example 5-twin-spoke wheels with mixed-size tyres: 225/40 R 18 at the front and, optionally, 255/35 R 18 at the rear.

The range of genuine accessories offers a wide selection of high-quality products to choose from. Please see our accessories brochure for further details or contact your Mercedes-Benz dealer, who will be pleased to advise you.



Roof rack with "Luxury" ski and snowboard rack.



Illuminated door sill panels with "Mercedes-Benz" lettering.



5-twin-spoke light-alloy wheels¹ (genuine accessories).

¹ Genuine accessory light-alloy wheels are supplied without tyres.



More than simply a star. A whole universe.

The range of **services from Mercedes-Benz**. Every Mercedes brings with it as a standard feature a reassuring feeling of safety on the road. But if you ever do need help, we're here for you around the clock. You can reach us from anywhere in Europe on the toll-free number 00800 1 777 7777¹ (or alternatively direct through Mercedes-Benz Contact²).

Ensuring that you can keep moving in the event of a technical breakdown, accident, vandalism or even misfuelling, the **Mercedes-Benz mobility package Mobilo³** is included as part of the standard specification. It covers the cost of local assistance, for example for towing your car away or for a replacement vehicle – and will do so in more than 40 countries across Europe for up to 30 years³. Furthermore, for the first four years following initial registration of the vehicle, Mobilo offers special mobility services in the case of workshop visits involving warranty or goodwill situations.

Avoid unexpected workshop costs⁴: a **Mercedes-Benz Service Contract** covers unforeseeable repairs, maintenance or wear parts, depending on the specific contract. Your local Mercedes-Benz dealer will be pleased to provide information about available Service Contracts and terms and conditions.

Mercedes-Benz Financial Services. Drive a Mercedes-Benz and remain flexible when it comes to payment: our attractive leasing and finance products make this possible – matched to your requirements and needs. We will also be happy to offer you a range of detailed insurance proposals. Just speak to your Mercedes-Benz dealer, who will be happy to provide information about our current range of financial services, terms and conditions.

¹ Alternatively: +49 69 95 30 72 77. Calls to a landline are chargeable. ² Calls from a mobile phone to a landline are chargeable. ³ When it expires, (four years after initial registration) Mobilo can be extended to up to 30 years from one service to the next by your authorised Mercedes-Benz service partner. ⁴ Mercedes-Benz service contract terms and conditions apply.

Enjoy the digital experience of Mercedes-Benz –

wherever you happen to be. Thanks to a range of offers optimised for smartphones and tablet computers, you can immerse yourself in the world of Mercedes-Benz even while on the move.

Insights into the full product range, a varied programme of entertainment and direct contact to a wide variety of services await you. Take an interactive tour with the **Interactive Owner's Manual**, for example, to get to know your dream car better. Experience the various functions in detail, take a close-up look at what's going on inside or explore the benefits of the particular model on your national Mercedes-Benz website.

With the **"Mercedes-Benz Guides"** app you can also explore the highlights of the various vehicles off-line. The app is available free of charge from the Apple® iTunes® Store (iOS) or the Google Play Store (Android).

Incidentally, our TV and magazine media are also available to watch and read digitally. Explore the whole brand world for yourself at www.mercedes-benz.com. Just click to take a look.

The **fascination of Mercedes-Benz**. A car whose name brings a gleam to the eyes of people all over the world, one that has featured in many a movie and been sung about in international hits, is surely far more than just a car. How did it come to this?

Discover just what has been moving the world for more than 125 years and take a fascinating journey through time as well as through the history of the automobile, in the **Mercedes-Benz Museum**. More than 1500 exhibits over a display area of 16500 square metres demonstrate the unique heritage and innovative power of the inventor of the automobile, among them one-off models such as the oldest Mercedes still in existence, built in 1902, or the legendary "Gullwing" cars. Welcome to a place of innovation: www.mercedes-benz-classic.com/museum

What would the history of Mercedes-Benz be like without **motorsport**? What would motorsport be without Mercedes-Benz? The first vehicle ever to win an automobile race was powered by a Daimler engine. The first Mercedes was a racing car. The Silver Arrows – a true legend. Out of this glorious past has grown an exciting present: the MERCEDES AMG PETRONAS Formula 1 team and the DTM Mercedes AMG C-Coupés fight it out weekend after weekend for points and victory.



Dimensions.

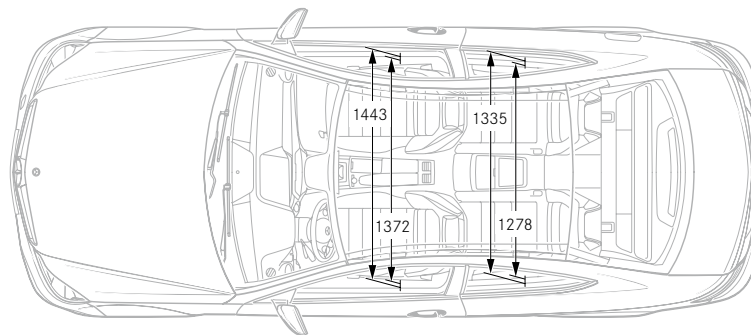
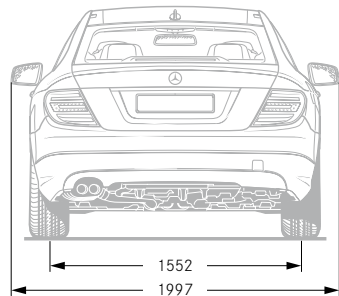
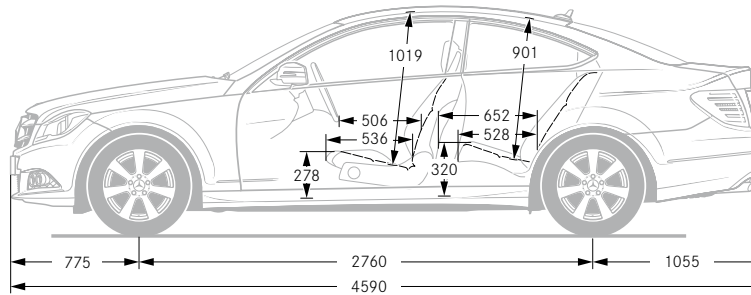
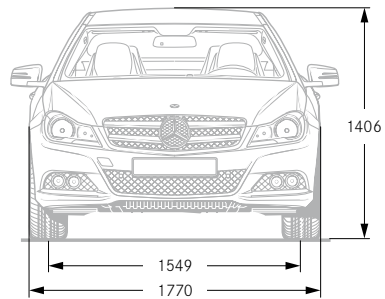

All dimensions in millimetres. The dimensions shown are mean values and apply to standard-specification, unladen vehicles.

Paintwork.

The paint system developed by Mercedes-Benz includes one of the best clear coats on the automotive market and is a key factor behind the car's excellent value retention. Its secret is the exceptionally thick molecular structure, which makes the metallic or non-metallic clear coat more resistant and produces a longer lasting and visibly more intensive shine.

Non-metallic paints (standard)

- 040 black
 - 149 polar white
 - 590 fire opal
-

Metallic paints (options)

- 183 magnetite black
 - 197 obsidian black
 - 755 tenorite grey
 - 775 iridium silver
 - 792 palladium silver
 - 890 cavansite blue
 - 988 diamond silver
-

designo paint (option)

- 799 designo diamond white bright
-

designo manufaktur paint (option)

- 051 designo platinum magno (option for C-Class Coupé Sport)
-

Additional individual designo paint finishes are available from your Mercedes-Benz dealer.

Technical data.

	Diesel engines			
	C 220 CDI	C 220 CDI BlueEFFICIENCY Edition	C 250 CDI	C 250 CDI Sport
No. of cylinders/arrangement	4/in-line	4/in-line	4/in-line	4/in-line
Total displacement in cc	2143	2143	2143	2143
Rated output ¹ in kW (hp) at rpm	125 (170)/3000-4200	125 (170)/3000-4200	150 (204)/3800	150 (204)/3800
Rated torque ¹ in Nm at rpm	400/1400-2800	400/1400-2800	500/1600-1800	500/1600-1800
Acceleration from 0 to 100 km/h in s	8.4 [8.1]	8.4	7.0 [7.1]	- [7.1]
Top speed, approx. in km/h	232 [231]	232	240 [240]	- [240]
Tyre size - front, rear	205/55 R 16	205/55 R 16	225/45 R 17	225/40 R 18, 255/35 R 18
Fuel	Diesel	Diesel	Diesel	Diesel
Fuel consumption ³ in l/100 km				
Urban	6.3-5.6 [6.5-6.1]	5.2	6.8-6.2 [6.5-6.1]	- [6.5]
Extra-urban	4.3-3.7 [4.6-4.2]	3.5	4.6-4.1 [4.6-4.2]	- [4.6]
Combined	5.1-4.4 [5.3-4.9]	4.1	5.4-4.9 [5.3-4.9]	- [5.3]
CO ₂ emissions ³ in g/km, combined	133-117 [139-128]	109	143-128 [139-128]	- [139]
Efficiency class	A [A]	A+	A [A]	- [B]
Emission class ⁴	Euro 5	Euro 5	Euro 5	Euro 5
Tank capacity in l/incl. approx. reserve	59/8	59/8	59/8	59/8
Load capacity in l	450	450	450	450
Turning circle diameter in m	10.84	10.84	10.84	10.84
Kerb weight ⁵ in kg	1615 [1630]	1615	1655 [1660]	- [1660]
Perm. GVW in kg	2085 [2100]	2085	2125 [2130]	- [2130]

¹ Figures in accordance with Directive 80/1269/EEC in the currently applicable version. ² Electronically limited. ³ The figures shown were obtained in accordance with the prescribed measuring process (Regulation [EC] 715/2007 in the respectively applicable version). The figures are not based on an individual model and do not constitute part of the product offer; they are provided solely for purposes of comparison between the different vehicle models. ⁴ Data applicable within the European Union only.

Petrol engines

C 180	C 200	C 250	C 250 Sport	C 350	C 63 AMG	C 63 AMG Edition 507
4/in-line	4/in-line	4/in-line	4/in-line	6/V	8/V	8/V
1595	1796	1796	1796	3498	6208	6208
115 (156)/5300	135 (184)/5250	150 (204)/5500	150 (204)/5500	225 (306)/6500	336 (457)/6800	373 (507)/6800
250/1250-4000	270/1800-4600	310/2000-4300	310/2000-4300	370/3500-5250	600/5000	610/5200
8.5 [8.5]	8.2 [7.8]	- [7.2]	- [7.2]	- [6.0]	- [4.4]	- [4.2]
225 [223]	237 [235]	- [240]	- [240]	- [250] ²	- [250] ²	- [280] ²
195/60 R 16	225/45 R 17	225/45 R 17	225/40 R 18, 255/35 R 18	225/45 R 17	235/40 R 18, 255/35 R 18	235/35 R 19, 255/30 R 19
Premium petrol	Premium petrol	Premium petrol	Premium petrol	Premium petrol	Super Plus petrol	Super Plus petrol
8.1-7.7 [8.0-7.7]	9.8-9.3 [9.1-8.8]	- [9.1-8.8]	- [9.1]	- [9.6-9.4]	- [18.2]	- [18.2]
5.4-4.7 [5.3-4.8]	5.8-5.2 [5.7-5.2]	- [5.7-5.2]	- [5.7]	- [5.6-5.3]	- [8.4]	- [8.4]
6.4-5.8 [6.3-5.8]	7.2-6.6 [7.0-6.5]	- [7.0-6.5]	- [7.0]	- [7.0-6.8]	- [12.0]	- [12.0]
149-136 [147-136]	168-154 [163-152]	- [163-152]	- [163]	- [164-159]	- [280]	- [280]
B [B]	C [C]	- [C]	- [D]	- [C]	- [G]	- [G]
Euro 6	Euro 5	Euro 5	Euro 5	Euro 5	Euro 5	Euro 5
59/8	59/8	59/8	59/8	66/8	66/14	66/14
450	450	450	450	450	450	450
10.84	10.84	10.84	10.84	10.84	11.10	11.10
1490 [1505]	1540 [1545]	- [1550]	- [1550]	- [1615]	- [1730]	- [1730]
1960 [1975]	2010 [2015]	- [2020]	- [2020]	- [2085]	- [2160]	- [2160]

² Figures according to Directive 92/21/EC, version 95/48/EC (kerb weight with fuel tank 90% full, driver, 68 kg, and luggage, 7 kg) for standard-specification vehicles. Optional extras and accessories will generally increase this figure and reduce the payload capacity accordingly. Figures in square brackets refer to engines with automatic transmission. Further technical data can be found at www.mercedes-benz.com

Non-metallic paints

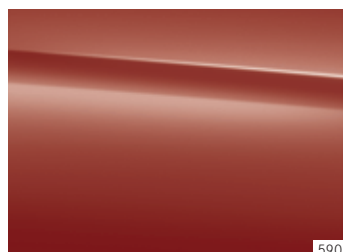

Metallic paints

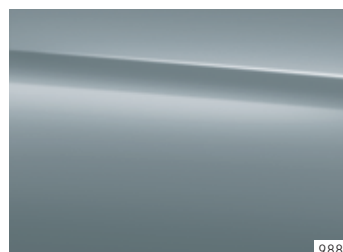
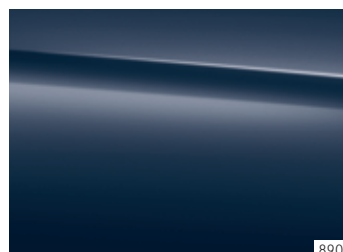
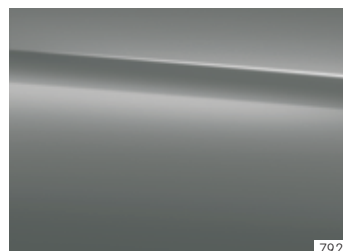
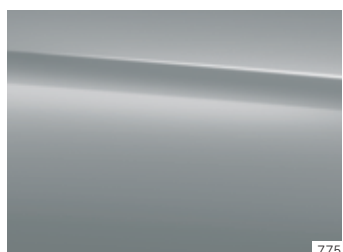
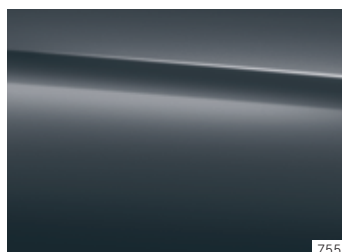
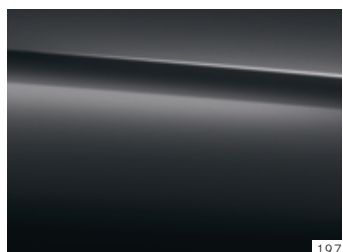
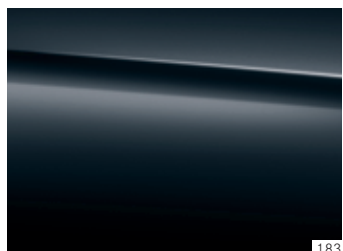

designo paint



designo manufaktur paint

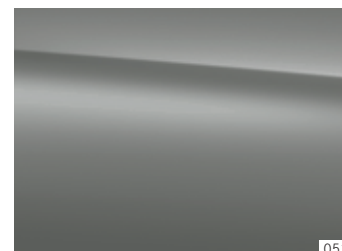

Take-back of end-of-life vehicles. At the end of its long life, you can return your C-Class to us for environment-friendly disposal in accordance with the European Union (EU) End-Of-Life Vehicle Directive. But that day lies a long way off.

A network of vehicle take-back depots and dismantlers has been established to make it as easy as possible for you to return your vehicle. You can leave it at any of these points free of charge and, by doing so, make an important contribution to completing the recycling process and conserving resources.

For further information about the recycling and disposal of end-of-life vehicles and take-back conditions, please visit your national Mercedes-Benz website.

Please note: changes may have been made to the product since this brochure went to press (27.01.2014). The manufacturer reserves the right during the delivery period to make changes to the design, form, colour or specification, provided these changes, while taking into account the interests of the vendor, can be deemed reasonable with respect to the purchaser. Where the vendor or the manufacturer uses symbols or numbers to describe an order or the subject of an order, no rights may be derived solely from these. The illustrations may include accessories and optional extras which do not form part of the standard specification. Actual colours may differ slightly from those shown owing to the limitations of the printing process. This brochure is distributed internationally. It provides a general indication of the range of models, features, optional extras, colours and/or services available in various countries. Some of the models, features, optional extras, colours and/or services shown may not be available in your country or may only be available in a different specification. Additionally some models, features, optional extras, colours and/or services may only be available in combination with others. For current and more specific information in relation to the range of models, features, optional extras, colours and/or services available in your country, and their pricing, you should contact your nearest authorised Mercedes-Benz Passenger Car Dealer.

www.mercedes-benz.com