

The G-Class.



Mercedes-Benz

This Brochure is prepared by Daimler AG and it predominantly reflects the capabilities and performance of vehicles sold in Europe.

Some characteristics, capabilities, performance features and optional extras (e.g. towing systems) may not be available or may not apply in Australia under Australian conditions. The information in this Brochure is therefore indicative, illustrative and provided only for guidance and should not be relied on. To obtain current and accurate information on a vehicle and any options applicable to Australia, contact your local authorised Mercedes-Benz dealer.

The G-Class. Nothing to add.

Rarely has a vehicle been more sure of what it is – and where it's going. It has all the attributes which make a Mercedes-Benz what it is: dynamism, comfort, safety and status. Yet it is different. Although it has been continually updated, modernised and equipped with technical innovations, the G-Class has remained true to its roots like practically no other vehicle: it has the same classic shape, the same rugged design, and the same mission to cope with extreme conditions, making it the only Mercedes-Benz that is at least as much at home off the road as on it. It is an unfailingly reliable partner which impresses whether parked at the kerbside or negotiating a mountainside. In fact, it is an object lesson in how to achieve perfection as there really is nothing left to add.



Featured model:

2 | Mercedes-Benz G 63 AMG designo magno platinum

AMG 5-twin-spoke light-alloy wheels, designo sand leather, AMG carbon-fibre trim

Details of further engines can be found starting on page 24.

The illustrations may include accessories and optional extras which do not form part of the standard specification.

Vision.

22 | Moving innovation

Drive system and chassis.

24 | Diesel and petrol engine

25 | AMG engines

26 | Transmissions

28 | Chassis and suspension

30 | On-/off-road systems

Safety.

34 | Integral safety concept

36 | G-Guard

Model variants.

38 | G-Class

40 | G 63 AMG

42 | G 65 AMG

Comfort.

44 | Multimedia systems

45 | Assistance systems and
Seat Comfort package

Equipment and appointments.

46 | Standard equipment

47 | Optional extras

48 | Equipment packages

54 | Upholstery and trim

58 | designo

68 | Wheels

70 | Services.

Facts and colours.

72 | Dimensions

72 | Paintwork

73 | Technical data





Its own way – the only road it never leaves.

In addition to its powerful appearance and high-performance engines, the G-Class possesses something that has made us particularly proud for the last 30 years: a strong character. So that this remains the case, our aim is to keep on further developing rather than redeveloping. A well-rounded character can still have corners and edges – it's about being true to yourself.



Off-road capability: either you've got it, or you fall by the wayside.

Special challenges call for special measures: engines whose capacity and power delivery are perfectly matched to the demands of this versatile cross-country vehicle are a case in point. They are complemented by three fully-lockable differential locks, which allow the G-Class to cope with the challenges presented by just about any driving situation or terrain. → Page 24-25, 30-33







Also built for the Hollywood hills.

Cruise in style around the hills of Bel Air or slog through the Mojave Desert in second gear? From the red carpet straight to the desert floor? No problem: extremes are the natural habitat of the G-Class. It copes with dramatic changes of scene or spur-of-the-moment detours with effortless superiority. The only limit is your imagination.



Knows the stones before
they're turned into asphalt.







At home in places others can only dream of reaching.

Ploughs its way through where others have to be dug out.

Climbing, fording, clambering, mud-plugging, slogging – it has to be said that terms like these do not usually find their way into a chassis design specification. But the G-Class relishes every challenge and gives you the reassuring feeling that you're never on your own when the going gets tough. Even if you've left lesser vehicles far behind.

→ Page 30–33





The height of luxury.

If you want to get to the top, you'll find you've pretty much made it as soon as you get in. But it's not just the commanding seating position that makes the G-Class so special. The comfort and optimised ergonomics also contribute to the driver's sense of well-being and the feeling of being in complete control. On the road or off the road, whether you're taking a drive in the mountains or heading for an economic summit.

→ Page 45



[gə'leɪnd]

გზისთვის

A single word can speak more eloquently than an entire manuscript. It projects pictures onto the retina of the mind's eye and sends emotions coursing straight to the heart. "Geländewagen" (the official German designation of the G-Class, which translates as "cross-country vehicle") is one such word. More than "off-roader" or "SUV", it conjures up images of loading supplies for an expedition, of poring over large-scale maps, of anticipation and excitement before the start and of the sense of being part of a great adventure. It is the invitation to plough through desert sands and the sense

of achievement on reaching places you had only ever dreamed of. It evokes the sound of the scree dislodged by the vehicle's progress, the swish of the tyres on endless sand tracks, the smell of rare drops of rain on parched grassland...

This inner film has countless plots, but always the same protagonist. Its name may not have found its way into the dictionary yet, but it has long occupied a unique place in the hearts of those who drive it: the G-Class.



Survival training.

The rain of the last few days has eroded the path so that it is now no more than a set of tyre tracks strewn with loose limestone scree. Someone has carved "I survived the Schöckl" into the bark of a beech tree. That just about says it all. Situated to the south of the Alps, the Schöckl is the birthplace of the G-Class – and one of the toughest off-road proving grounds in the world.

Can it really be that demanding? As if in answer, a G-Class suddenly bursts through the undergrowth, negotiates the rocky ascent noisily, treating knee-deep holes in its path with complete indifference as it goes. No sooner has it reached the top than the professional driver at the wheel hurls the Mercedes-Benz back down the slope again. The G-Class covers at least 30,000 kilometres under conditions such as these during the test phase. Because a vehicle that has survived the worst that the Schöckl can throw at it will be able to take just about any other challenge it may encounter in its stride.



The stuff that legends are made of.

Deutschmann nods. A slow, well-considered nod. Quite possibly the most influential head movement in the whole of the Graz Bergland region.

Some of his team watch him out of the corner of their eye before quickly getting back down to work again. With as many as 45,985 stitches to be placed, not to mention the countless cuts and folds, complete concentration and absolute precision are essential. The end result is then subjected to scrutiny by Herr Deutschmann, who has cast his unforgiving gaze over every G-Class for 33 years. A nod means excellent work. And if there is no nod? A vehicle which fails to attain the summit of perfection will never be allowed to leave the production facility in this picturesque, mountainous region of Austria.

The bobbins on the sewing machines hum as up to 810 metres of thread are dispatched on their mission to hold together the very heart and soul of every vehicle. No loop is too large, no stitch as much as a millimetre out of place. This accuracy and attention to detail reflect the passion which these skilled specialists – who are among the finest exponents of their craft – put into ensuring that every G-Class is a genuine Mercedes-Benz.

What makes a car a Mercedes?

Deep-rooted traditions: in our case, it is innovative traditions that run deep. We've gone along previously untravelled roads. Setting milestone after milestone. The first car with a crumple zone, the first ABS, the first diesel car. The first car. And whilst it's nice to look back, we'd much rather look forward.

Mercedes me – welcome to a world that revolves entirely around you. We focus on people. No more so than when we developed a new platform for you to keep in close contact with Mercedes-Benz. With services that are tailored to your needs. “connect me” connects the vehicle to your world of experience, to everything that is important to you. “move me” provides new mobility solutions. And “inspire me” gives you an exclusive insight into the future of mobility. Your gateway to a fascinating world: www.mercedes.me



Mercedes-Benz Intelligent Drive – on the road to accident-free driving. We develop intelligent technologies that actively assist the driver and make driving tangibly easier. Valuable assistance systems are already available in your Mercedes-Benz: they help to maintain the distance to the vehicle in front automatically, brake the car when necessary and warn against imminent rear-end collisions or vehicles in the blind spot. The sensors of the driving assistance and safety systems are linked intelligently. Potential hazardous situations are detected earlier than ever and, consequently, avoided with increasing regularity. Discover the fascinating world of Mercedes-Benz Intelligent Drive at www.mercedes-benz-intelligent-drive.com

BlueEFFICIENCY – our vision of emission-free driving. Sustainability is a big word. And it's a prime consideration in absolutely everything we do. From minimising the environmental impact of our production operations to alternative drive concepts.

The aims are ambitious, as you can see. But what could be better than seeing these aims achieved whilst on a long drive in a Mercedes?

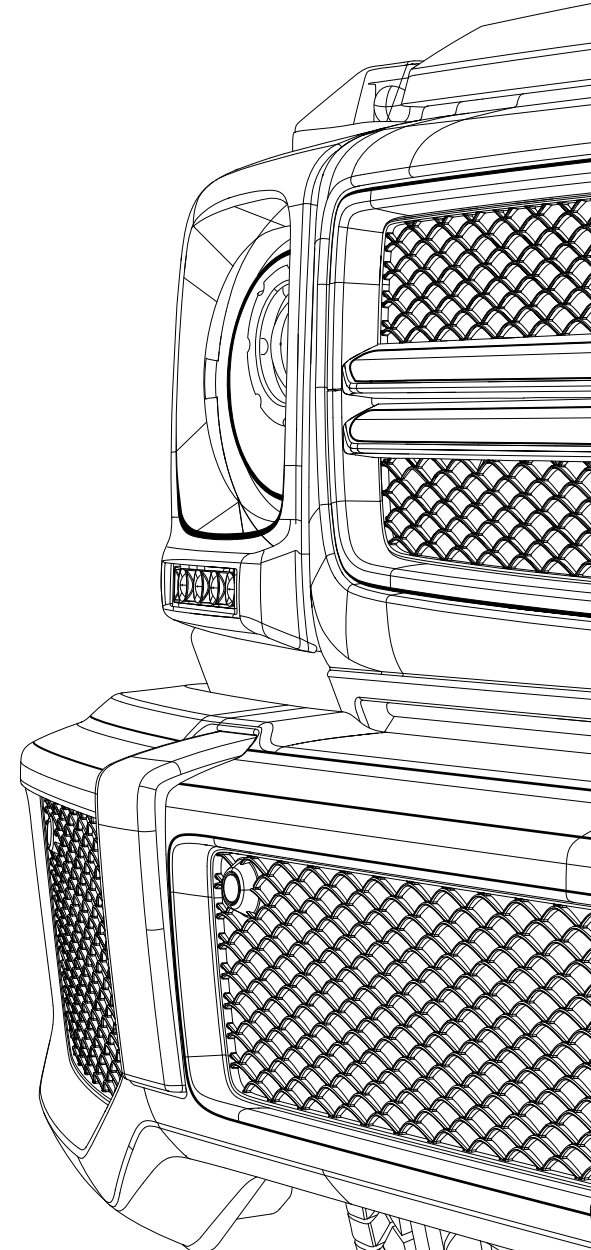

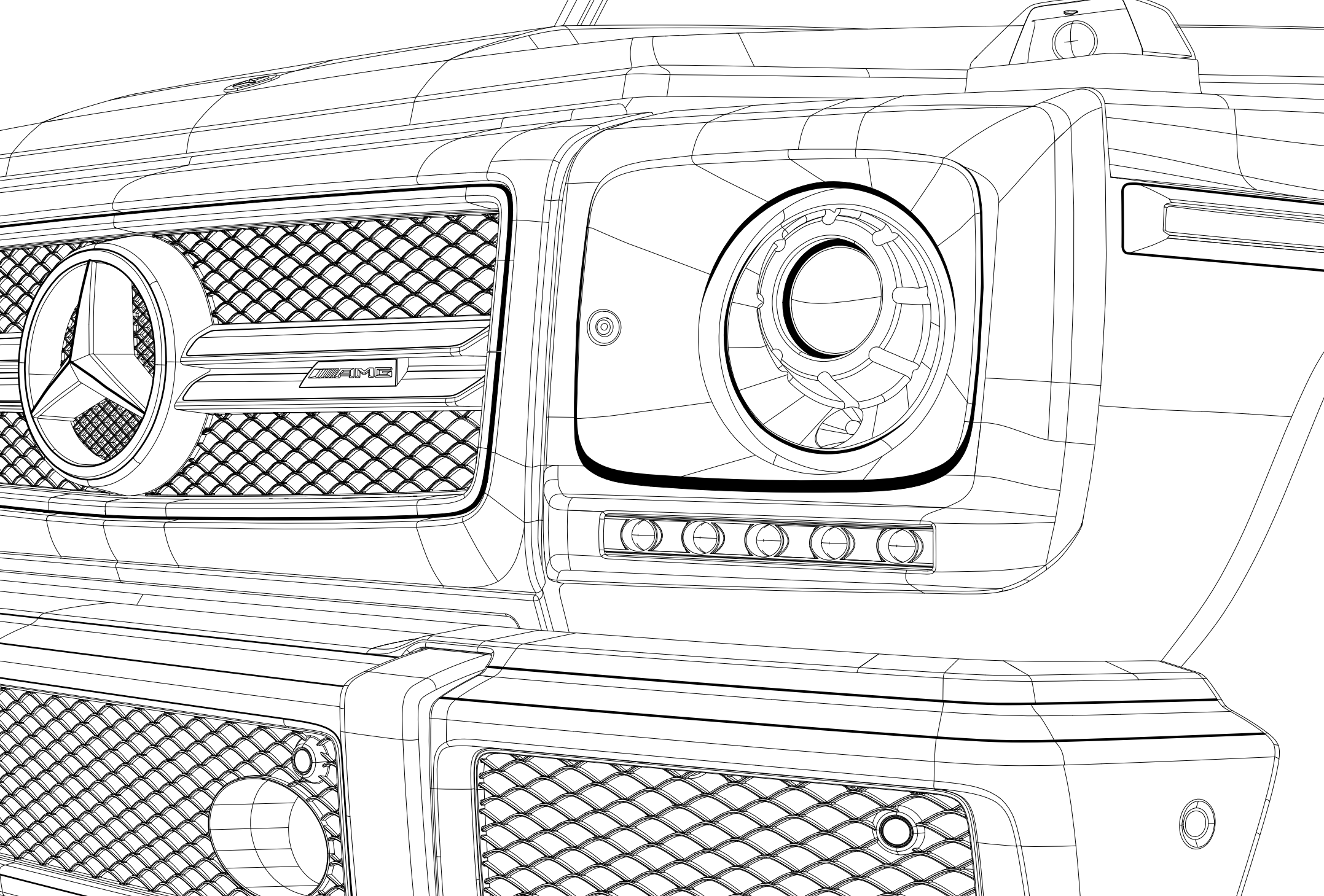

Diesel and petrol engine.

Plenty of torque on the road and off it: both the diesel and the petrol engine provide effortlessly superior power delivery for the G-Class.

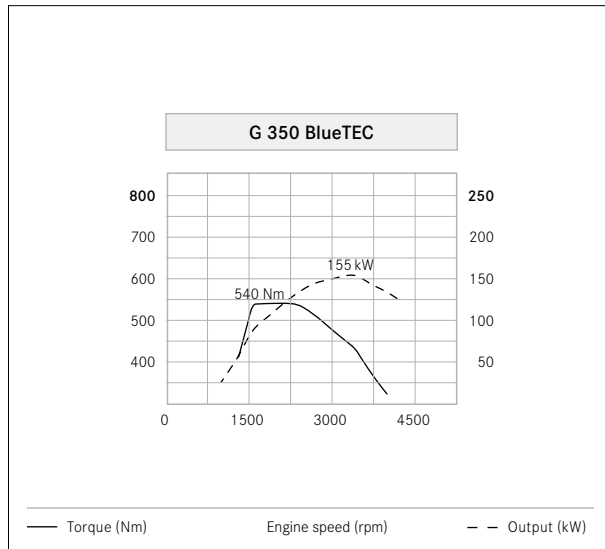

The G 350 BlueTEC achieves its maximum torque of 540 Nm early – between 1600 and 2400 rpm.

6-cylinder diesel engine. Although the V6 common-rail diesel in the G 350 BlueTEC develops 155 kW (211 hp), it is optimised to reduce fuel consumption. Thanks to precise piezo injectors, an injection pressure of up to 1600 bar and an optimised turbocharger, it attains a maximum torque of 540 Nm. Advanced catalytic converter technology helps to reduce this compression-ignition engine's emissions of nitrogen oxides by up to 80%. Cleaning and aftertreatment of the exhaust gases are carried out with the help of AdBlue® urea solution. If "Refill AdBlue®" appears on the display, the reduction agent can be replenished in a process as simple as refuelling. Containers of ISO 22241-compliant AdBlue® are available in the Mercedes-Benz Accessories range.

8-cylinder petrol engine. As well as being more than a match for even the most challenging terrain, the G 500 with its rated output of 285 kW (387 hp) is equally at home on fast motorway runs. The maximum torque of 530 Nm is available across a wide engine speed range from 2800 to 4800 rpm. This means that the G 500 accelerates from 0 to 100 km/h in 6.1 seconds and attains a top speed of 210 km/h. Optimum engine performance and reduced fuel consumption are ensured by infinitely variable intake and exhaust camshaft adjustment, four valves per cylinder and lightweight materials, such as magnesium, from the world of motorsport. The cylinder intake and exhaust ducts ensure an optimum air supply and so contribute to the increased output with reduced emissions. The characteristic V8 sound completes the G 500 experience.

AMG engines.

The two AMG 8- and 12-cylinder high-performance engines for the G 63 AMG and G 65 AMG offer maximum driving pleasure for drivers who like to make the most of their vehicles' power reserves.

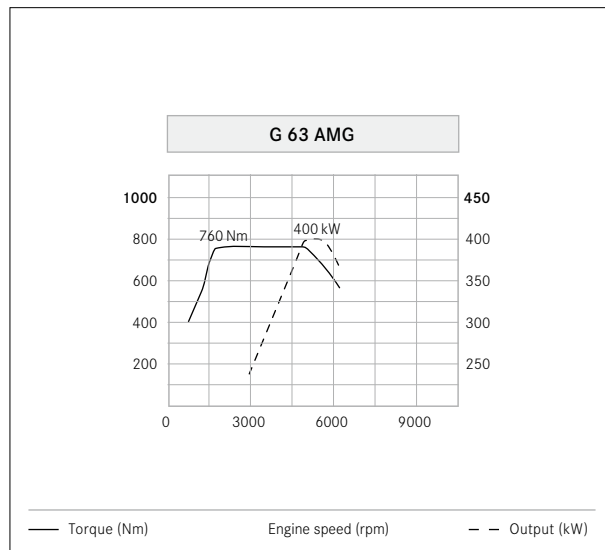

The impressive torque of 760 Nm is available across a broad engine speed range from 2000 to 5000 rpm.

AMG 8-cylinder petrol engine. The responsive AMG 5.5-litre V8 twin-turbocharged engine of the G 63 AMG develops a maximum output of 400 kW (544 hp) and maximum torque of 760 Nm from its 5461 cc displacement. No other engine in this output category attains the performance of the new AMG powerplant. Acceleration from 0 to 100 km/h takes 5.4 seconds with the top speed electronically limited to 210 km/h. Spray-guided direct petrol injection with piezo injectors and twin turbochargers, four valves per cylinder with camshaft adjustment, air-to-water intercooling and the ECO start/stop function blend high efficiency with high output. The result is an engine which reconciles an involving, compelling driving experience with a degree of responsibility which is exceptional in this vehicle class and output category.

AMG 12-cylinder petrol engine. Featuring the ultimate in advanced technology, the 12-cylinder twin-turbocharged engine of the G 65 AMG offers performance figures unprecedented in this vehicle class. This top-of-the-range engine equipped with two turbochargers and an intercooler develops 450 kW (612 hp) with maximum torque of 1000 Nm (governed) which is available across the engine speed range from 2300 to 4300 rpm. The G 65 AMG accelerates from 0 to 100 km/h in 5.3 seconds and rapidly attains its electronically governed top speed of 230 km/h. Its responsiveness and smooth, refined running characteristics ensure typical Mercedes comfort on long journeys accompanied by the classic, rich, 12-cylinder sound.

Transmissions.

Whether called on to deliver dynamic on-road performance or an agile response to the challenges of off-road use, **7G-TRONIC** and **AMG SPEEDSHIFT PLUS 7G-TRONIC** are matched precisely to the different engines and adjust to the driving situation and driving style.



7G-TRONIC (standard for G 350 BlueTEC and G 500). This automatic transmission increases ride comfort thanks to its particularly smooth gear change action. The spread over seven speeds means that the ideal ratio is always available and so ensures constant progress in the optimum engine speed range. This makes a measurable contribution to reducing fuel consumption and driving noise. Thanks to its multiple downshift capability, **7G-TRONIC** can skip individual gears – jumping straight from seventh to fifth when overtaking, for example. Driving dynamics are also enhanced by the very short shift times enabled by **7G-TRONIC**. Furthermore, there is no longer any interruption in tractive power during gear changes. Optimised driving characteristics when climbing, operating off-road or towing a trailer are the result.

The G-Class enjoys excellent shift quality thanks to **7G-TRONIC**.



The AMG SPEEDSHIFT PLUS 7G-TRONIC transmission manages power intelligently.

AMG SPEEDSHIFT PLUS 7G-TRONIC (standard for G 63 AMG and G 65 AMG). Now available in the G-Class for the first time, the AMG SPEEDSHIFT PLUS 7G-TRONIC represents automatic transmission technology in its highest form. The dynamic output of the AMG engines is managed brilliantly by the AMG SPEEDSHIFT PLUS 7G-TRONIC automatic transmission which ensures that the output of 400 kW (544 hp)/760 Nm or 450 kW (612 hp)/1000 Nm (depending on engine version) is delivered to the permanent all-wheel drive absolutely smoothly. Even more impressive is the fact that it does this with extremely short shift times and without any interruption to the flow of forward-thrusting power.

ECO start/stop function (standard for G 63 AMG).

Exemplary fuel consumption figures are attained thanks to the ECO start/stop function. In the “C” – Controlled Efficiency – driving mode this function switches the engine off when the vehicle is stationary. When moving off again, the transmission shifts automatically into second gear. Shifting takes place as early as possible, for higher torque at lower revs, improved efficiency and reduced CO₂ emissions.

Chassis & suspension.

With its ladder-type frame, rigid axles, long suspension travel and high ground clearance of 21 cm, the G-Class is well-equipped to cope with even the most challenging terrain.

Ladder-type frame. The design of the G-Class, which makes it less vulnerable and more rugged than vehicles with an integral body, is also responsible for its exceptional durability and value retention. The ladder-type frame forms the extremely sturdy, load-bearing basis of the G-Class. Its bending resistance means that it is particularly well equipped to withstand the rigours of extended use in tough terrain. The frame is formed by two parallel longitudinal members, each of which consists of two U-shaped half-shells which are welded together and con-

nected by cross tubes. The body is bolted to the frame at eight points and rests on rubber mountings to keep vibration transmission to a minimum. In order to ensure the best possible corrosion protection, the frame is powder-coated, surface-treated and then painted. All cavities are waxed, the frame undergoes cathodic dip priming, and the underbody is given an additional plastic coating. In this way, the body offers practically no point of attack for water, snow, road salt or even desert sand. An important advantage of the solid, torsionally stiff ladder-type frame

lies in its ability to absorb torsional forces arising along the longitudinal axis and so prevent them from being transmitted to the body. Furthermore, the ladder-type frame forms the lowest part of the vehicle with no components projecting below it, the only exception being the axles. This protects the vehicle in the event of ground contact when operating in off-road terrain.

Steering. The power steering of the G-Class is specially designed for the rigours of off-road use. It owes its resilience and durability to the absence of vulnerable steering gaiters or rubber bellows. What's more, the power steering offers a high degree of driving comfort and uses the traditional recirculating-ball principle to prevent shocks from being transmitted to the driver's hands when negotiating obstacles.



The G-Class is exceptionally stable and durable thanks to its ladder-type frame.

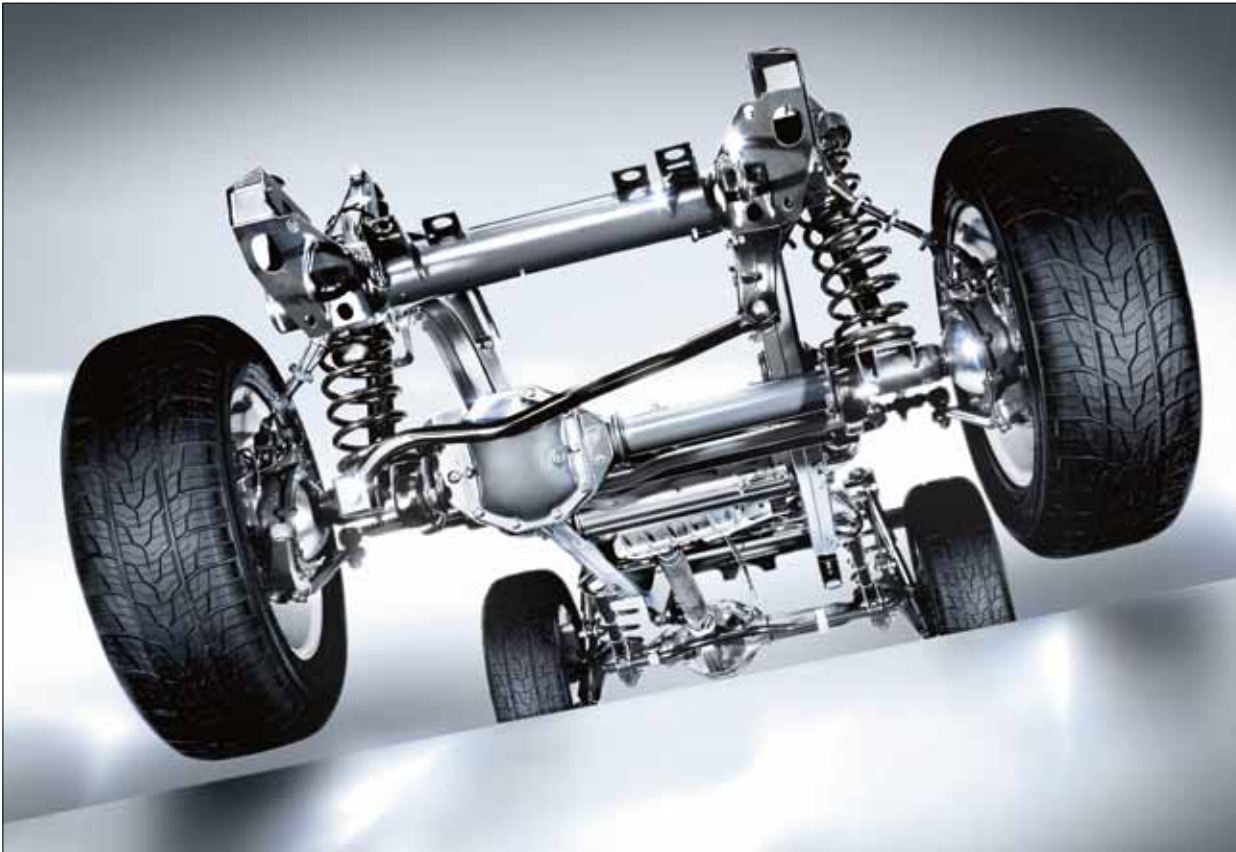

Rigid axles are extremely resilient, even when subjected to heavy loads during off-road driving, and offer constant ground clearance as well as optimum traction.

Rigid axles. The chassis of the G-Class offers several advantages over independent suspension which is designed for on-road vehicles. It is based on two rigid axles, each of which is controlled by two solid longitudinal arms and one transverse control arm. Coil springs with long spring travel ensure good axle articulation, high ground clearance and outstanding traction off the road as well as agile and comfortable handling on it. High-performance gas-filled shock absorbers prevent any see-sawing effect from building up while two anti-roll bars, optimised in line with the vehicle's performance, kerb weight and payload, effectively reduce the body roll typically suffered by off-road vehicles during cornering. As both wheels of an axle are connected by high-strength steel tubes, their camber is always constant. The high degree of axle articulation and the even distribution of the wheel load across each axle enable ground clearance to be maintained at all times – even in the case of large obstacles – and are beneficial with regard to traction, too. These advantages also apply when negotiating challenging off-road terrain.

On-/off-road systems.

Outstanding off-road performance and reliable tractive power even under extreme conditions – the drive system.

Permanent all-wheel drive including 4ETS. The permanent all-wheel drive of the G-Class, the synchromesh transfer case with selectable low-range gear, the electronic traction system 4ETS as well as the three fully lockable differential locks form an ideal team. The permanent all-wheel drive ensures that all wheels always have the best possible traction and makes for improved driving dynamics and enhanced driving stability. As a rule, power is distributed between the front and rear wheels in a 50:50 ratio. The 4ETS electronic traction system is a component of ESP®. It applies an individual braking force to any wheels

which are spinning and diverts the drive torque to the wheel or wheels with the best traction in the current situation. As a result, it is also possible to move off or accelerate when confronted with difficult conditions – such as ice – on the road or in less demanding off-road terrain. In challenging off-road terrain, the rigid axles provide the necessary ground clearance and outstanding traction to allow the permanent all-wheel drive to realise its full potential.

Differential locks. The three fully lockable differential locks which can be engaged electrically ensure that the G-Class can even cope with challenging terrain in which only one wheel is able to gain traction. During extreme off-road use, it is possible to lock the front axle differential and the rear axle differential as well as the centre differential in the transfer case. The locks are engaged in accordance with the increasing need for traction by means of three switches in the centre console. 4ETS and ESP® are automatically switched off when the locks are engaged. With the differentials fully locked, exactly the same rotational speed is found at both axles and at each wheel. In this fully locked condition, the vehicle can proceed even if only one wheel has traction. This means that the G-Class is able to free itself from what would otherwise be an inextricable situation.

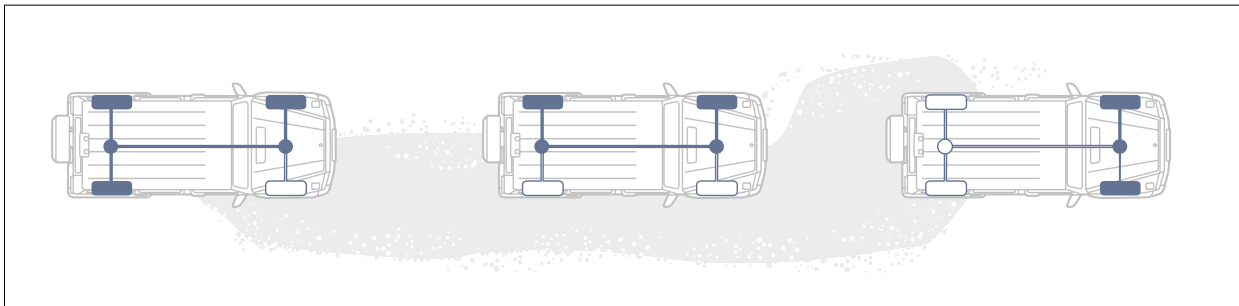

The 4ETS electronic traction system automatically transfers the drive torque to the wheels with the best traction.



On-/off-road systems.

Sheer power, controlled intelligently: the low-range ratio, the three 100% locking differential locks, the electronic traction system 4ETS and the design make the G-Class a high-performance cross-country vehicle.

Low-range ratio (figures apply to standard production version). During ventures into difficult terrain, the driver is supported by the standard-fit low-range ratio integrated in the transfer case. If the transmission is set to “neutral”, a press of the low-range button at speeds below 40 km/h is all that is required to optimise the transmission of the

engine torque. In this way, it is possible to benefit from greater tractive force and improved control when operating at lower speeds. As a result, the vehicle can climb slopes with an incline of up to 100% (80% in the case of the AMG models) – or negotiate descents more easily without the wheel locking. This is particularly important on changing

and slippery surfaces, such as rock, grass or snow, as it ensures enhanced driving stability. The risk of the rear of the vehicle breaking away can be prevented and steering control can be maintained.

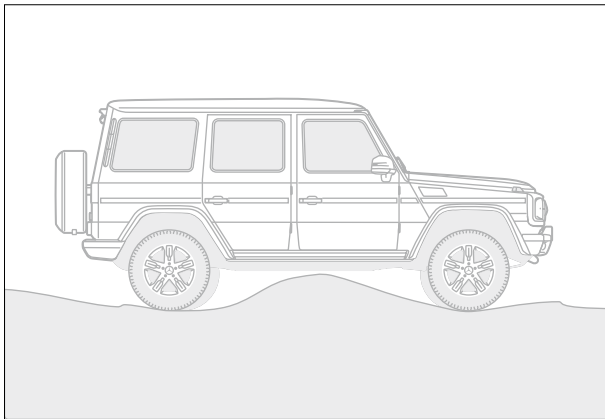

Ground clearance: 21 cm (AMG models: 22 cm).

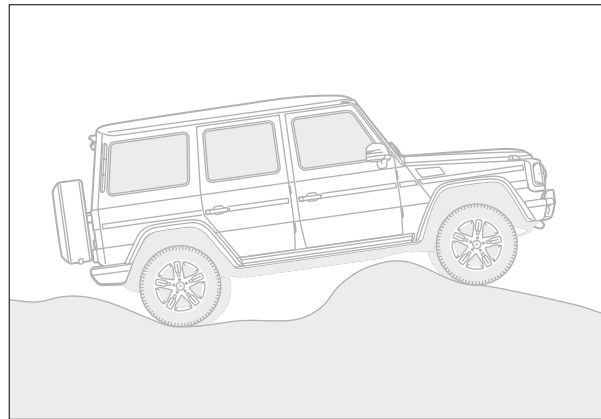

Breakover angle: 24°.

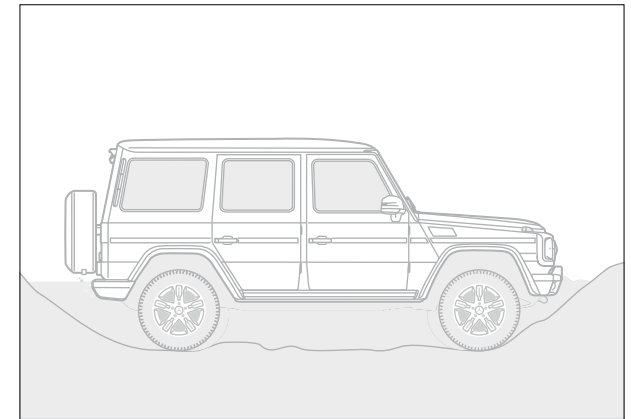

Maximum fording depth: 60 cm.

Special characteristics of the G-Class. A unique feature of the G-Class are the three 4ETS on-/off-road systems, the two-stage transfer case plus three fully lockable differential locks. The interplay between these systems allow operation in practically any terrain. Two rigid axles and protected drive components ensure

robust cross-country capability and maximum axle articulation. The G-Class can climb gradients of up to 100% (80% in the case of AMG models), where the surface conditions allow, remains directionally stable on lateral slopes of up to 54%, has ground clearance of 21 cm (AMG models: 22 cm) and can progress through water and mud with a

foraging depth of up to 60 cm. Finally, the angle of approach is 36° (AMG models: 27°), the angle of departure is 27° and the breakover angle, as a function of the ground clearance, is also comparatively large.

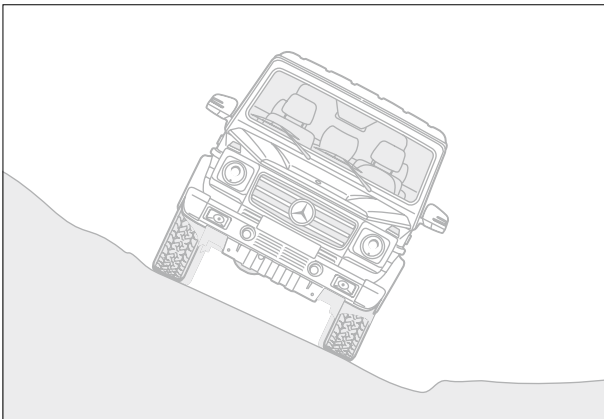

Directionally stable on lateral slopes of up to 54%.

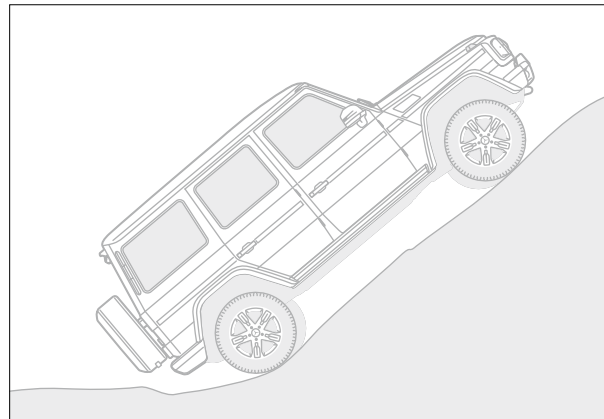

Slope-climbing ability up to 100% (80% in the case of AMG models), depending on ground condition.

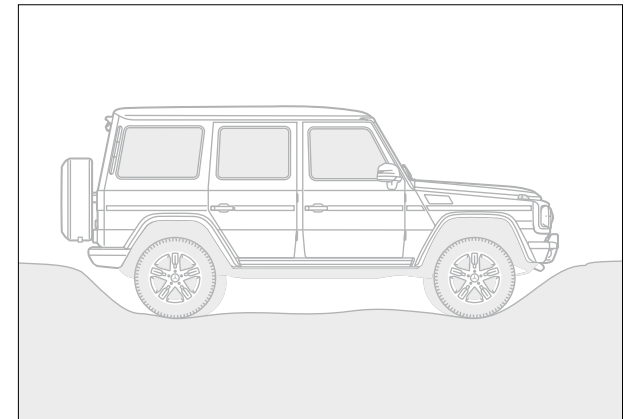

Angle of approach: 36° (AMG models: 27°). Angle of departure: 27°.

Integral safety concept.

Driven by our vision of accident-free driving. With our integral safety concept we are coming closer to achieving this goal – this is a holistic approach which can increase safety in every situation.

ESP®, incl. vehicle/trailer stabilisation (standard).

Control systems optimise the performance of the braking system: the ESP® can apply a selective braking force to individual wheels if necessary. Together with the ABS it provides greater stability when cornering. If an emergency braking situation is detected, Brake Assist BAS can provide emergency braking assistance. The ADAPTIVE BRAKE system's HOLD function can stop the vehicle from rolling backwards or forwards unintentionally in stop-and-go traffic or when waiting at traffic lights. Vehicle/trailer stabilisation can prevent oscillation of the vehicle/trailer combination.

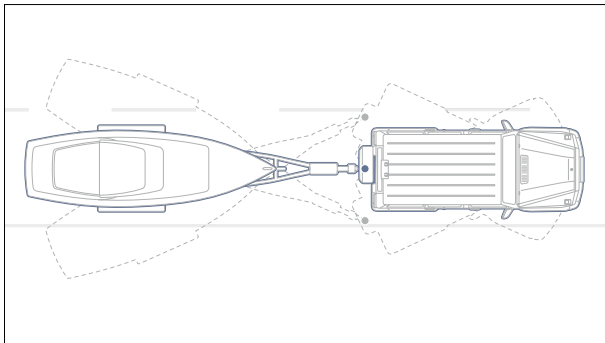

Vehicle/trailer stabilisation helps to ensure a safer journey when towing.

LED daytime running lamps (standard). The LED daytime running lamps are a characteristic feature of the vehicle's appearance and allow it to be seen more easily by other road users. The LEDs are arranged in light strips integrated in the headlamp surrounds.



The LED daytime running lamps underline the appearance of the vehicle while enhancing safety.

NECK-PRO luxury head restraints (standard for all models except the G 65 AMG). The crash-responsive NECK-PRO luxury head restraints on the front seats can help to reduce the risk of whiplash injury. In the event of a rear impact, the head restraints are pushed forwards by around 40 millimetres and upwards by 30 millimetres, thus providing support for the heads of the front seat occupants at an earlier stage. The flexible side bolsters of the NECK-PRO luxury head restraints provide additional lateral support while also enhancing seating comfort.

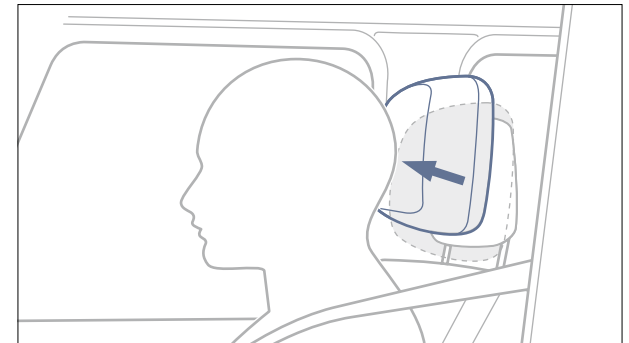

The NECK-PRO luxury head restraints can reduce the risk of whiplash injuries significantly in the event of a rear impact.

Airbags (standard). The G-Class has front airbags fitted as standard (with a seat occupancy sensor for the front passenger seat). Furthermore, the driver's airbag responds adaptively in the event of an accident, deploying in one or two stages depending on the predicted impact severity and the characteristics of the accident. The G-Class is additionally equipped with large windowbags, which deploy in the head area, as well as pelvisbags to protect the pelvic and hip areas. Plus there are sidebags to provide protection for the upper body and pelvic area in the event of a side impact.

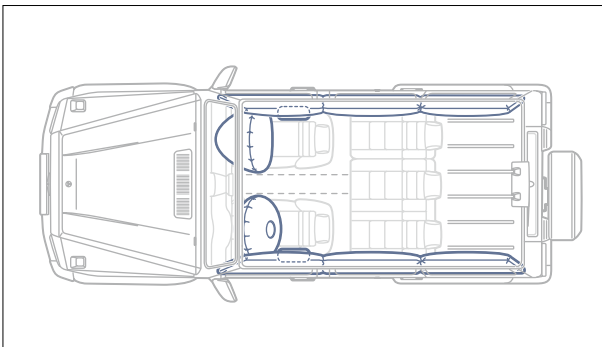

Windowbags covering both rows of seats are standard, as are airbags, pelvisbags and sidebags for the driver and front passenger.

DISTRONIC PLUS (option). This adaptive cruise control system uses a heated radar sensor to maintain the distance to the vehicle in front. Depending on the traffic situation – and even in snow and icy conditions – the system can throttle back or apply the brakes. If the gap is closing too quickly, an audible warning is given. Operating in a speed range of 0 to 200 km/h, the system reduces the strain on the driver, especially on motorways and in heavy traffic. Where emergency braking is required, Brake Assist (BAS) makes the necessary brake pressure available.



DISTRONIC PLUS adaptive cruise control helps the driver maintain the desired distance between the G-Class and the vehicle in front.

Blind Spot Assist (option). The optionally available Blind Spot Assist monitors the blind spot directly to the side of and behind the vehicle at speeds above 30 km/h. If the assistance system detects the danger of an impending collision when changing lane, it can warn the driver by means of a symbol in the exterior mirror. If the driver ignores this and activates the indicator, an additional audible warning is triggered.



Blind Spot Assist can increase safety when changing lane.



Better safe than sorry. A promise rather than a saying.

Maximum protection, poise and assurance – on and off the road: the G-Guard.

The “G” in this G-Class also stands for Guard. The G-Guard has been fulfilling its brief of providing the best possible level of occupant protection for more than 30 years. The latest version features an integrated protection system that, although barely noticeable on the outside, has been extensively further developed on the inside. Because the G-Guard incorporates safety-enhancing measures and components that are precisely adapted to each other very early on in the development phase. The result: highest protection at its best, even in extreme terrain.

In addition to the standard Mercedes-Benz quality and safety tests, the G-Guard undergoes a series of ballistic tests under the direction of independent and internationally recognised authorities. These tests confirm that the G-Guard meets the requirements for resistance level VR7 as per BRV 2009. This resistance class and the reinforcement of some of the glazed areas up to class 10 ensure that protection really does mean bullet-resistant protection. So although you may go weak for this vehicle, it will not go weak for you.

For the first time, the G-Guard also offers protection against DM31 mines in accordance with ERV2010 and STANAG 4569. This protection can be further enhanced by adding an explosion-proof fuel tank and fuel lines, for example. In a nutshell: we normally build cars that make your pulse race. This one does the opposite.



The special, laminated glass is shatterproof and bulletproof.



The fire extinguishing system, which can be deployed manually or automatically, can stop fire from breaking out in the interior.



Perfectly hidden behind the appearance of a series-production car, the integrated protection system delivers all that's needed to keep you safe.

The G-Class.

A timeless design classic, an exciting off-road legend, an overwhelming desire for freedom: the G-Class.

Clean lines and large, flat surfaces have defined the side view of the G-Class for over 30 years. The large window areas with heat-insulating glass between the A-, B-, C- and D-pillars, and especially the two large rear side windows, are a characteristic feature of this four-door model with its 2850 mm wheelbase. The side skirts as well as the beltline and roof edge are parallel for much of their length, as are the horizontal rub strips at door-handle height. More than just visual expressions of strength and stability, the distinctive wheel-arch treatment, the rear section



Clean lines and characteristic design.

which widens towards the base and the wide track make a practical contribution to the almost unlimited off-road capability of the G-Class. The spacious cross-country vehicle also offers the occupants of the rear seats maximum comfort, both on long journeys and in challenging terrain, with features such as seat heating as standard. Another advantage of the G-Class is its large load compartment which has a maximum capacity of 2250 litres and is accessed easily via a large tailgate hinged on the driver's side. All this space can be used flexibly thanks to the



Also extreme: the travel comfort offered by the G-Class.

1/3:2/3 split folding rear bench seat and the load retainers. A load compartment cover and a cargo net are optionally available. As the engine and chassis are designed for a towing capacity of 3.5 tonnes, the G-Class also lends itself to towing a boat, horse box or caravan, not least because of its ability to cope with difficult surface conditions.



Ready to take on any terrain with lots of equipment on board.



G 63 AMG.

The AMG G-Class models are in a class of their own. The G 63 AMG raises the bar yet again. → www.mercedes-amg.com



With a rated output of 400 kW (544 hp), the G 63 AMG develops maximum torque of 760 Nm yet remains extremely efficient thanks to the standard-fit ECO start/stop function. Exterior highlights: metallic paint, AMG radiator grille with chromed twin louvres, AMG wheel-arch flaring with “V8 BITURBO” logo, AMG exhaust system with twin chromed side tailpipes, AMG 5-twin-spoke light-alloy wheels in titanium grey with red painted brake callipers and 275/50 R 20 tyres. The stylish look is completed to perfection by the standard-fit Exterior Stainless Steel package.

Interior: illuminated AMG stainless steel door sill panels, seats in designo leather, leather-trimmed dashboard and AMG performance steering wheel as well as door centre panels in ruffled leather, headlining in black DINAMICA microfibre plus ambient lighting. The standard-fit Chrome package with designo trim in a choice of three versions complements the dynamic impression created by the interior which can also be ordered with carbon-fibre trim.



G 65 AMG.

The most powerful G-Class of all time makes no secret of its unique position among high-performance cross-country vehicles. → www.mercedes-amg.com



The first G-Class to be equipped with a V12 engine, the G 65 AMG develops 450 kW (612 hp) from a displacement of 5980 cc and maximum torque of 1000 Nm. The phenomenal pulling power and acceleration represented by these figures are matched by the exceptional standard equipment with metallic paint and the Exterior Stainless Steel package. Also included are AMG 5-spoke light-alloy wheels with 275/50 R 20 tyres and red-painted brake callipers framed by AMG wheel-arch flaring with a “V12 BITURBO” logo as well as an AMG exhaust system with twin chromed tailpipes on both sides of the vehicle and an appropriately impressive sound. Particularly striking features are the AMG radiator grille with chromed twin louvres backed by the characteristic diamond-pattern mesh, also in chrome, as well as brushed aluminium-effect inserts with AMG lettering. In addition to these features, the G 65 AMG is equipped as standard with an AMG performance steering wheel and all the exclusive details of the Chrome package.



The G 65 AMG is equipped as standard with the designo Exclusive package with AMG front sports seats. The seats and door centre panels as well as the insert in the tail-gate are trimmed in diamond-pattern designo leather while black designo leather features on the upper and lower sections of the dashboard. The two-tone designo leather interior is available in six combinations.

The front seats of the G 65 AMG have NECK-PRO luxury head restraints bearing an embossed AMG emblem. Also standard is the Seat Comfort package including climatized multicontour front seats.

Multimedia systems.

As well as supporting the driver with navigation assistance, the multimedia systems in the G-Class serve above all to provide entertainment tailored to the individual requirements of all the passengers.

COMAND Online (standard). This feature combines audio and navigation systems with telephone and internet functionality. Entertainment is provided by a DVD drive and the Music Register with a 10 GB hard disc, the standard USB and Bluetooth® interface plus online access via an internet-capable mobile phone. LINGUATRONIC allows the functions to be operated by voice entry. In the latest version the features it boasts include photo-realistic map display, Windows and iPhone® compatibility plus internet radio. With an optional TV receiver, passengers in the G-Class can even watch broadcast television programmes.



The multimedia system with hard-disc navigation has a high-resolution 17.8 cm colour display.

Harman Kardon® Logic 7® surround sound system (option). Equipped with 12 loudspeakers and a 10-channel DSP amplifier, this 450-watt Dolby Digital 5.1 system provides first-class acoustics for all seats. The 3D surround sound and speed-sensitive volume control ensure constant listening pleasure.



12 loudspeakers and 450 watts for full-bodied sound: the Harman Kardon® Logic 7® surround sound system.

Rear Seat Entertainment System (option). The Rear Seat Entertainment System fitted to the rear of the front head restraints comprises two DVD players with TFT colour display (17.8 cm diagonal), remote control, Aux-in connections and two sets of wireless headphones. Rear passengers can watch films or connect a games console during the journey. Both displays can be used independently of one another.



The two displays for the Rear Seat Entertainment System mounted on the front-seat head restraints.

Assistance systems and Seat Comfort package.

A range of assistance systems and enhanced seating comfort can make the driver's task easier in a number of ways.

Parking package (option). The Parking package, which includes a reversing camera and PARKTRONIC Parking Assist, makes parking much easier. The reversing camera with a wide-angle lens monitors the area directly behind the vehicle and sends the images to the COMAND display. It is activated automatically when reverse gear is engaged. PARKTRONIC can warn the driver automatically if there is a risk of the space in front of or behind the vehicle becoming tight when parking or manoeuvring. The system

operates on the echo sounder principle. Sensors on the front and rear bumpers emit ultrasound signals, which are then reflected by other vehicles or obstacles. A micro-computer then calculates the current distance and informs the driver.

Seat Comfort package (option, standard for G 65 AMG). The climatized multicontour seats of the Seat Comfort package make journeys in the G-Class – especially long ones – particularly comfortable. Features such as electric height adjustment and continuously variable seat cushion inclination adjustment for the front seats enhance comfort and ergonomics noticeably. The lumbar support can prevent symptoms of fatigue by providing additional support for the back. It is certified and recommended by AGR, a German association which promotes high-quality orthopaedic design.



The reversing camera shows the area behind the vehicle during parking.



The PARKTRONIC LEDs indicate the distance to the obstacle.

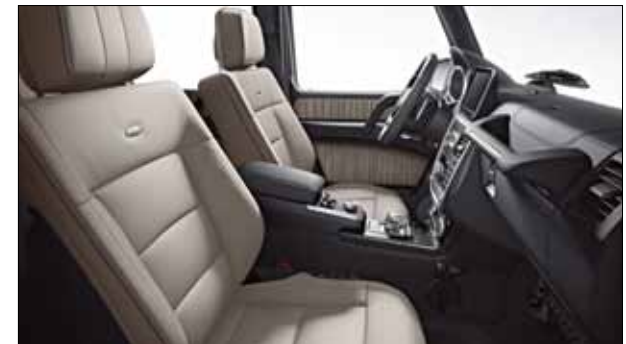

Multicontour seats can enhance driver-fitness safety.

Standard equipment | Selection.



Instrument cluster with colour display.



Differential locks.



Central display.



Electric seat adjustment with Memory function.



THERMATIC automatic climate control.



COMAND Controller.



Ambient lighting.



Bi-xenon headlamps with LED daytime running lamps.

Optional extras | Selection.



Carbon-fibre trim.



Harman Kardon® Logic 7® surround sound system.



Heated multifunction steering wheel.



AMG selector lever.



Sliding roof, electric.



Auxiliary heater with remote control.



Ball-head trailer coupling.



Privacy glass fitted in rear and load compartment side windows as well as tailgate.

Chrome package.

Brilliantly expressive: the Chrome package stands for heightened elegance.



With its three chromed louvres, the optional Chrome package (standard for AMG models) makes a brilliant impression. In the case of the AMG models, this is underlined in an exclusive way by the additional differentiation of the radiator grille design. Inside, stylish design elements, continuous chrome trim around the wooden fascia for the seat adjustment switches and chrome rings around the loudspeakers in the front doors embody a new level of individuality which extends to the smallest details. The theme continues all the way to the chromed load sill protection which features “Mercedes-Benz” lettering or “AMG” lettering (in the case of AMG models).

Exterior Stainless Steel package.

Clarity, elegance, refinement: stainless steel simply conveys that certain something.



An interesting enhancement for the G-Class is available in the form of the Exterior Stainless Steel package (standard for AMG models), featuring running boards and a spare wheel cover in stainless steel with a 3D Mercedes star.



Sports package.

Ensures that the G-Class makes a particularly sharp impression: the Sports package.



The stripe-effect inserts in anthracite are irresistibly sporty.



The stainless steel spare wheel cover is a brilliant finishing touch.

The optional Sports package (for G 350 BlueTEC and G 500) gives the design of the G-Class additional dynamism and individualises it to a high standard. The Sports package includes the Exterior Stainless Steel package with left and right running boards and a spare wheel cover in stainless steel with a 3D Mercedes star. AMG wings and optionally available 5-spoke light-alloy wheels in titanium grey with 265/60 R 18 tyres add particularly powerful emphasis to the exterior design. Rub strips with inserts in stripe-effect anthracite and a sports exhaust system (for G 500 only) complete the impressive picture. Velour floor mats provide the final interior touch for the package. The Sports package is only available in conjunction with the Chrome package.



Exclusive package.

As the name suggests: an exceptional combination of high-quality appointments.



The optional Exclusive package (for G 350 BlueTEC and G 500) combines fine appointments to meet exacting requirements. In combination with upholstery in leather or designo leather the dashboard is trimmed in leather. The driver and front passenger benefit from the comfort offered by the multiple adjustment options provided by the climatized multicontour seats from the Seat Comfort package. Ambient lighting integrated in the dashboard, door trim and footwells can be dimmed to any level to highlight the stylish interior and create a unique lighting atmosphere. Even the process of getting in and out is accompanied by a special lighting effect thanks to the illuminated door sill panels. Headlining in black DINAMICA microfibre adds the finishing touch to this high-quality interior. The Exclusive package offers an interesting starting point for further individualisation of the G-Class. The Seat Comfort package is also available as an option on its own.

designo Exclusive package.

The designo Exclusive package lends the interior an exceptionally exclusive ambience.



The distinguished character of the AMG models is underlined to great effect by the designo Exclusive package (optional for G 63 AMG, standard for G 65 AMG). It features sports seats in two-tone designo leather – available in six colour schemes – for the driver and front passenger. The door centre panels as well as the cushions of all the seats have a quilted diamond pattern. The dashboard trimmed in designo leather and the AMG emblem (an additional feature of the G 65 AMG) on the head restraints make it perfectly clear that this is no ordinary vehicle – and that the quality and character of the interior are also exceptional. The designo Exclusive package is only available in conjunction with the Seat Comfort package (standard for G 65 AMG).



Upholstery and trim.



For the black colour scheme it is possible to choose between seat covers in fabric and optional upholstery in leather. The interior is predominantly in black with contrast provided by the standard grey headlining. DINAMICA microfibre headlining in black is standard for AMG vehicles and an option for all others in combination with fabric upholstery or leather appointments. Trim elements in anthracite poplar wood are standard in combination with a black nappa leather steering wheel for the G 350 BlueTEC. Trim elements in high-gloss brown burr walnut wood are available as an option in combination with a wood/leather steering wheel in high-gloss brown burr walnut. The black colour scheme can also be combined with optional designo trim elements.



SP1



•



ZG8



V56



ZT0

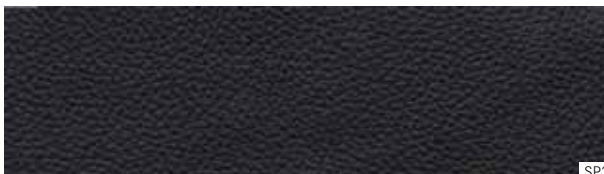

SP3

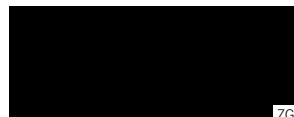

ZG2



ZG6

Black
SP1 Fabric ¹
SP3 Leather ²
Trim
• anthracite poplar wood ¹
V56 high-gloss brown burr walnut wood ³
ZG2 designo black piano lacquer wood ⁴
ZG8 designo champagne white piano lacquer wood ⁵
ZT0 designo light brown poplar wood with satin finish ⁵
ZG6 AMG carbon fibre ⁶

¹ Standard for G 350 BlueTEC, not available for G 500, G 63 AMG, G 65 AMG. ² Optional extra, standard for G 500, not available for G 63 AMG, G 65 AMG. ³ Optional extra, standard for G 500, no-cost option for G 63 AMG, G 65 AMG. ⁴ Optional extra, standard for G 63 AMG, G 65 AMG. ⁵ Optional extra, no-cost option for G 63 AMG, G 65 AMG. ⁶ Optional extra.



The optional alpaca grey colour scheme has leather upholstery. The interior is predominantly in grey with contrast provided by the steering wheel, dashboard and carpet in black. DINAMICA microfibre headlining in black is standard for AMG vehicles and an option for all others. Standard for the G 350 BlueTEC: trim elements in anthracite poplar wood in combination with a black nappa leather steering wheel. Trim elements in high-gloss brown burr walnut wood are available as an option in combination with a wood/leather steering wheel in high-gloss brown burr walnut. The alpaca grey colour scheme can also be combined with optional designo trim elements.



SP4



ZG8



V56

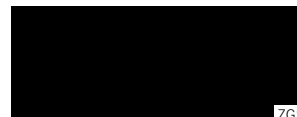

ZG2



ZG6



ZT0



ZG6

Alpaca grey

SP4 Leather¹

Trim

- anthracite poplar wood²

V56 high-gloss brown burr walnut wood³

ZG2 designo black piano lacquer wood⁴

ZG8 designo champagne white piano lacquer wood⁵

ZT0 designo light brown poplar wood with satin finish⁵

ZG6 AMG carbon fibre⁶

¹ Optional extra, no-cost option for G 500, not available for G 63 AMG, G 65 AMG. ² Standard for G 350 BlueTEC, not available for G 500, G 63 AMG, G 65 AMG. ³ Optional extra, standard for G 500, no-cost option for G 63 AMG, G 65 AMG.

⁴ Optional extra, standard for G 63 AMG, G 65 AMG. ⁵ Optional extra, no-cost option for G 63 AMG, G 65 AMG. ⁶ Optional extra.



The optional chestnut brown colour scheme has leather upholstery. The interior is predominantly in brown with contrast provided by the standard steering wheel, dashboard and carpet in black as well as by the grey headlining. DINAMICA microfibre headlining in black is standard for AMG vehicles and an option for all others. Trim elements in anthracite poplar wood are standard in combination with a steering wheel in black nappa leather for the G 350 BlueTEC. Trim elements in high-gloss brown burr walnut are available as an option in combination with a wood/leather steering wheel in high-gloss brown burr walnut. The chestnut brown colour scheme can also be combined with optional designo trim elements.



Chestnut brown

SP5 Leather¹

Trim

- anthracite poplar wood²
- V56 high-gloss brown burr walnut wood³
- ZG2 designo black piano lacquer wood⁴
- ZG8 designo champagne white piano lacquer wood⁵
- ZT0 designo light brown poplar wood with satin finish⁵
- ZG6 AMG carbon fibre⁶

¹ Optional extra, no-cost option for G 500, not available for G 63 AMG, G 65 AMG. ² Standard for G 350 BlueTEC, not available for G 500, G 63 AMG, G 65 AMG. ³ Optional extra, standard for G 500, no-cost option for G 63 AMG, G 65 AMG. ⁴ Optional extra, standard for G 63 AMG, G 65 AMG. ⁵ Optional extra, no-cost option for G 63 AMG, G 65 AMG. ⁶ Optional extra.



designo.

Individuality at its most alluring: the comprehensive designo range of optional paint finishes and interior appointments gives any G-Class its own uniquely luxurious identity.

→ www.mercedes-benz.com/designo

designo appointments allow customers seeking a unique identity for their vehicles to select their appointments in accordance with their own particular ideas and preferences. All design requests are implemented using carefully chosen materials which are painstakingly crafted by hand using traditional skills. In the case of the G-Class, the range comprises eight different exclusive designo paint finishes: designo metallic (designo mocha black metallic, designo graphite metallic, designo platinum black metallic), designo bright (designo mystic blue bright, designo mystic red bright, designo mystic brown bright) and the designo magno matt paint finishes (designo magno platinum and designo magno night black).

The interior indulges the senses with high-quality, hand-stitched single-tone designo leather upholstery, again in

a choice of eight attractive colours: designo porcelain, designo marron, designo classic red, designo black, designo light brown, designo sand, designo mystic red and designo titanium grey pearl. The appointments also comprise door panels in ruffled leather, velour floor mats with a designo leather surround and headlining in black DINAMICA microfibre. In the case of the G 63 AMG the upholstery in designo leather is included as standard. And in the case of the G 65 AMG it even takes the form of two-tone designo leather with an exclusive quilted diamond pattern. The most eye-catching interior features are the designo wood/leather steering wheel and the selector lever with an AMG emblem – included as standard for AMG models. The optional designo Exclusive package (standard for the G 65 AMG) can be ordered to enhance the G 63 AMG, which is already equipped as standard with

a comprehensive selection of high-quality appointments, with even more impressive details. Climatized multi-contour front seats must also be fitted when the designo Exclusive package is ordered.



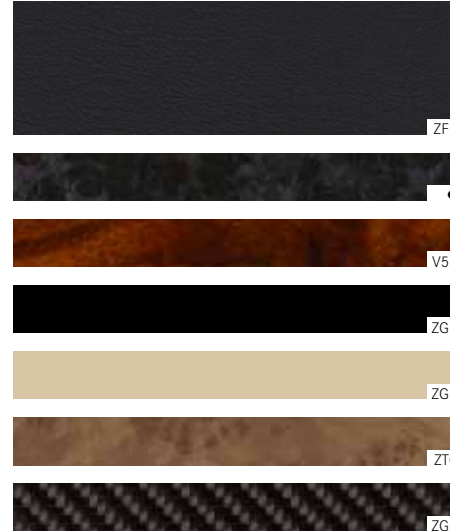

designo black leather (option)

ZF7 designo leather¹

Trim

- anthracite poplar wood²
- V56 high-gloss brown burr walnut wood³
- ZG2 designo black piano lacquer wood¹
- ZG8 designo champagne white piano lacquer wood⁴
- ZT0 designo light brown poplar wood with satin finish⁴
- ZG6 AMG carbon fibre⁵

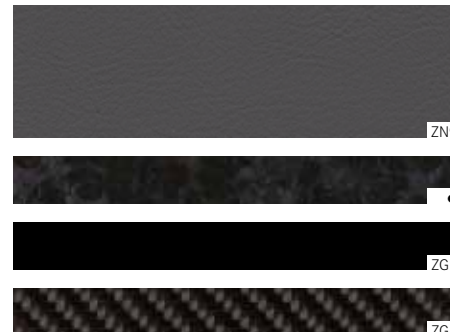

designo titanium grey pearl leather (option)

ZN9 designo leather⁴

Trim

- anthracite poplar wood²
- ZG2 designo black piano lacquer wood¹
- ZG6 AMG carbon fibre⁵

¹ Optional extra, standard for G 63 AMG, G 65 AMG. ² Standard for G 350 BlueTEC, not available for G 500, G 63 AMG, G 65 AMG. ³ Optional extra, standard for G 500, no-cost option for G 63 AMG, G 65 AMG. ⁴ Optional extra, no-cost option for G 63 AMG, G 65 AMG. ⁵ Optional extra.

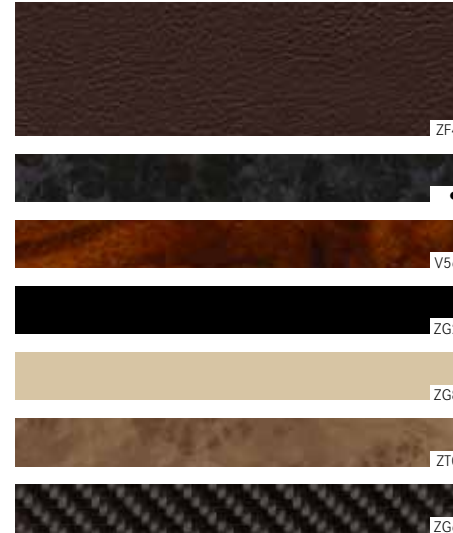

designo marron leather (option)

ZF4 designo leather^{4, 6}

Trim

- anthracite poplar wood²
- V56 high-gloss brown burr walnut wood³
- ZG2 designo black piano lacquer wood¹
- ZG8 designo champagne white piano lacquer wood⁴
- ZT0 designo light brown poplar wood with satin finish⁴
- ZG6 AMG carbon fibre⁵

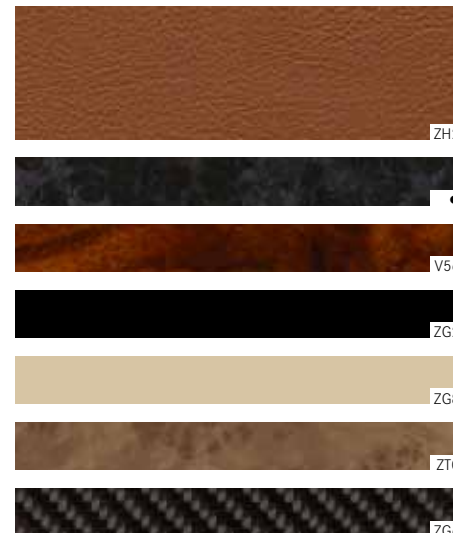

designo light brown leather (option)

ZH2 designo leather⁴

Trim

- anthracite poplar wood²
- V56 high-gloss brown burr walnut wood³
- ZG2 designo black piano lacquer wood¹
- ZG8 designo champagne white piano lacquer wood⁴
- ZT0 designo light brown poplar wood with satin finish⁴
- ZG6 AMG carbon fibre⁵

¹ Optional extra, standard for G 63 AMG, G 65 AMG. ² Standard for G 350 BlueTEC, not available for G 500, G 63 AMG, G 65 AMG. ³ Optional extra, standard for G 500, no-cost option for G 63 AMG, G 65 AMG. ⁴ Optional extra, no-cost option for G 63 AMG, G 65 AMG. ⁵ Optional extra. ⁶ Not in conjunction with the designo Exclusive package (PA6) and not available for G 65 AMG.

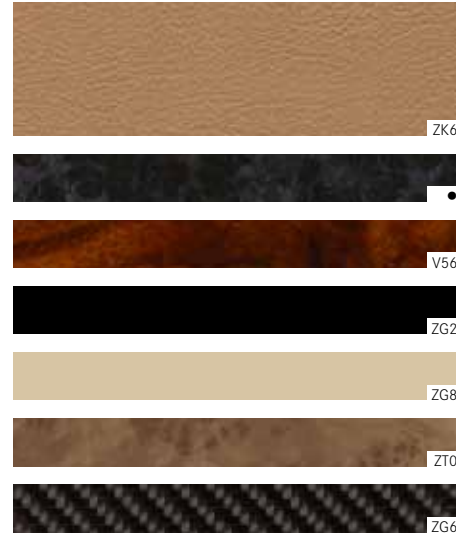

designo sand leather (option)

 ZK6 designo leather⁴

Trim

- anthracite poplar wood²

 V56 high-gloss brown burr walnut wood³

 ZG2 designo black piano lacquer wood¹

 ZG8 designo champagne white piano lacquer wood⁴

 ZT0 designo light brown poplar wood with satin finish⁴

 ZG6 AMG carbon fibre⁵

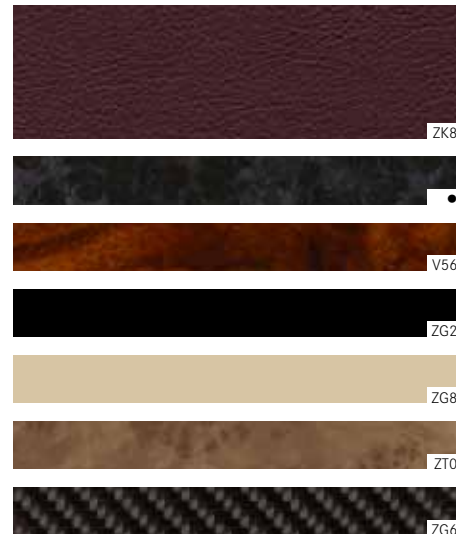

designo mystic red leather (option)

 ZK8 designo leather^{4, 6}

Trim

- anthracite poplar wood²

 V56 high-gloss brown burr walnut wood³

 ZG2 designo black piano lacquer wood¹

 ZG8 designo champagne white piano lacquer wood⁴

 ZT0 designo light brown poplar wood with satin finish⁴

 ZG6 AMG carbon fibre⁵

¹ Optional extra, standard for G 63 AMG, G 65 AMG. ² Standard for G 350 BlueTEC, not available for G 500, G 63 AMG, G 65 AMG. ³ Optional extra, standard for G 500, no-cost option for G 63 AMG, G 65 AMG.

⁴ Optional extra, no-cost option for G 63 AMG, G 65 AMG. ⁵ Optional extra. ⁶ Not in conjunction with the designo Exclusive package (PA6) and not available for G 65 AMG.

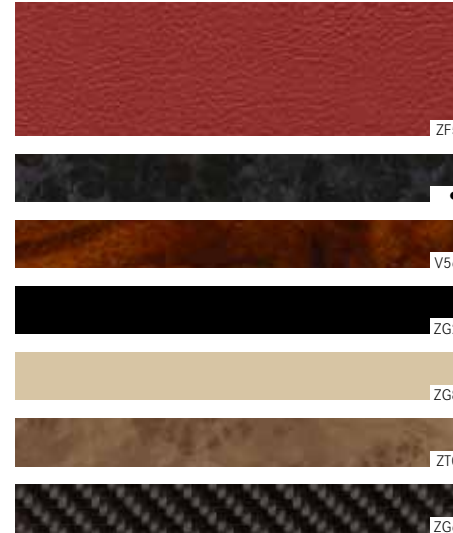

designo classic red leather (option)

ZF5 designo leather⁴

Trim

- anthracite poplar wood²
- V56 high-gloss brown burr walnut wood³
- ZG2 designo black piano lacquer wood¹
- ZG8 designo champagne white piano lacquer wood⁴
- ZT0 designo light brown poplar wood with satin finish⁴
- ZG6 AMG carbon fibre⁵

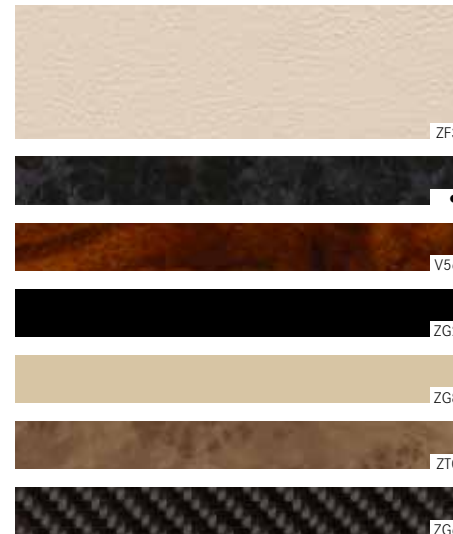

designo porcelain leather (option)

ZF3 designo leather⁴

Trim

- anthracite poplar wood²
- V56 high-gloss brown burr walnut wood³
- ZG2 designo black piano lacquer wood¹
- ZG8 designo champagne white piano lacquer wood⁴
- ZT0 designo light brown poplar wood with satin finish⁴
- ZG6 AMG carbon fibre⁵

¹ Optional extra, standard for G 63 AMG, G 65 AMG. ² Standard for G 350 BlueTEC, not available for G 500, G 63 AMG, G 65 AMG. ³ Optional extra, standard for G 500, no-cost option for G 63 AMG, G 65 AMG. ⁴ Optional extra, no-cost option for G 63 AMG, G 65 AMG. ⁵ Optional extra.



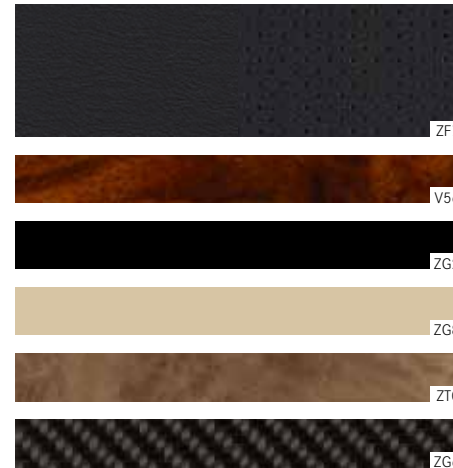

designo black/black leather (option)⁵

ZF7 designo leather

Trim

V56 high-gloss brown burr walnut wood²

ZG2 designo black piano lacquer wood¹

ZG8 designo champagne white piano lacquer wood³

ZT0 designo light brown poplar wood with satin finish³

ZG6 AMG carbon fibre⁴

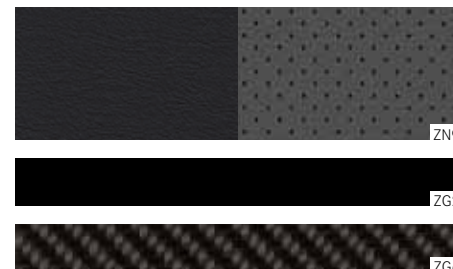

designo black/titanium grey pearl leather (option)⁵

ZN9 designo leather

Trim

ZG2 designo black piano lacquer wood¹

ZG6 AMG carbon fibre⁴

¹ Optional extra, standard for G 63 AMG, G 65 AMG. ² Optional extra, standard for G 500, no-cost option for G 63 AMG, G 65 AMG. ³ Optional extra. No-cost option for G 63 AMG and G 65 AMG. ⁴ Optional extra. ⁵ Only available for G 63 AMG and G 65 AMG. Only in conjunction with PA6, standard for G 65 AMG.

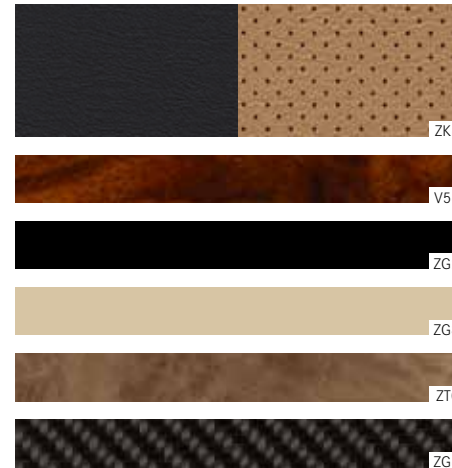

designo black/sand leather (option)⁵

ZK6 designo leather

Trim

V56 high-gloss brown burr walnut wood²

ZG2 designo black piano lacquer wood¹

ZG8 designo champagne white piano lacquer wood³

ZT0 designo light brown poplar wood with satin finish³

ZG6 AMG carbon fibre⁴

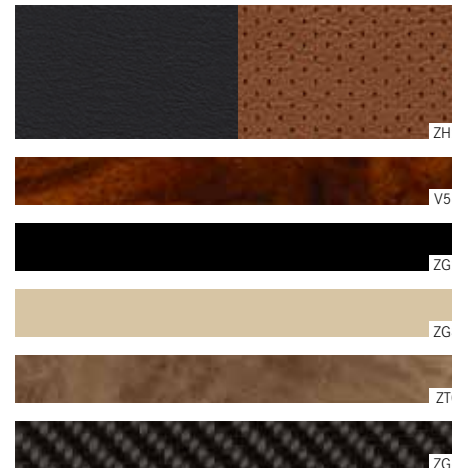

designo black/light brown leather (option)⁵

ZH2 designo leather

Trim

V56 high-gloss brown burr walnut wood²

ZG2 designo black piano lacquer wood¹

ZG8 designo champagne white piano lacquer wood³

ZT0 designo light brown poplar wood with satin finish³

ZG6 AMG carbon fibre⁴

¹ Optional extra, standard for G 63 AMG, G 65 AMG. ² Optional extra, standard for G 500, no-cost option for G 63 AMG, G 65 AMG. ³ Optional extra. No-cost option for G 63 AMG and G 65 AMG
⁴ Optional extra. ⁵ Only available for G 63 AMG and G 65 AMG. Only in conjunction with PA6, standard for G 65 AMG.

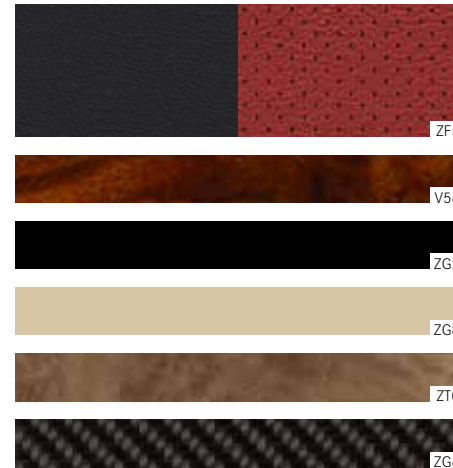

designo black/classic red leather (option)⁵

ZF5 designo leather

Trim

V56 high-gloss brown burr walnut wood²

ZG2 designo black piano lacquer wood¹

ZG8 designo champagne white piano lacquer wood³

ZT0 designo light brown poplar wood with satin finish³

ZG6 AMG carbon fibre⁴

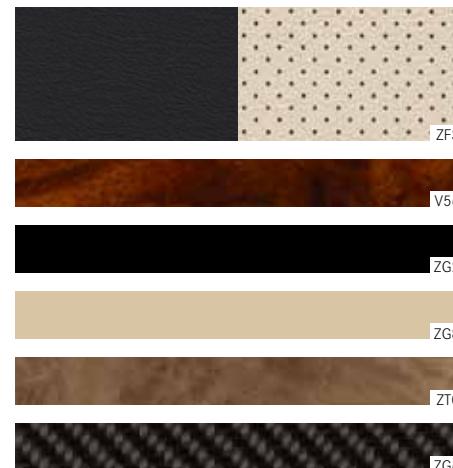

designo black/porcelain leather (option)⁵

ZF3 designo leather

Trim

V56 high-gloss brown burr walnut wood²

ZG2 designo black piano lacquer wood¹

ZG8 designo champagne white piano lacquer wood³

ZT0 designo light brown poplar wood with satin finish³

ZG6 AMG carbon fibre⁴

¹ Optional extra, standard for G 63 AMG, G 65 AMG. ² Optional extra, standard for G 500, no-cost option for G 63 AMG, G 65 AMG. ³ Optional extra. No-cost option for G 63 AMG and G 65 AMG. ⁴ Optional extra. ⁵ Only available for G 63 AMG and G 65 AMG. Only in conjunction with PA6, standard for G 65 AMG.

Wheels.



5-spoke light-alloy wheels with 265/70 R 16 tyres (standard for G 350 BlueTEC, Code RL3).



6-spoke light-alloy wheels with 265/60 R 18 tyres, with high-sheen finish (optional for G 350 BlueTEC, G 500, Code RL6).



5-twin-spoke light-alloy wheels with 265/60 R 18 tyres (standard for G 500, optional for G 350 BlueTEC, Code RM9).



5-spoke light-alloy wheels with 265/60 R 18 tyres, painted titanium grey with high-sheen finish (standard for Sports package, optional for G 350 BlueTEC, G 500, Code RL5).



5-twin-spoke light-alloy wheels with 265/60 R 18 tyres, painted titanium grey (optional, only for Sports package, Code RM9).



AMG 5-spoke light-alloy wheels with 275/50 R 20 tyres, painted titanium grey with high-shine finish (standard for G 65 AMG, Code RM1).



AMG 5-twin-spoke light-alloy wheels with 275/50 R 20 tyres, painted titanium grey with high-shine finish (standard for G 63 AMG, Code R10).



AMG 5-spoke light-alloy wheels with 275/50 R 20 tyres, painted matt black with high-shine finish (optional for G 63 AMG, G 65 AMG, Code R11).



More than simply a star. A whole universe.

The range of **services from Mercedes-Benz**. Every Mercedes brings with it as a standard feature a reassuring feeling of safety on the road. But if you ever do need help, we're here for you around the clock. You can reach us from anywhere in Europe on the toll-free number 00800 1 777 7777¹ (or alternatively direct through Mercedes-Benz Contact²).

Ensuring that you can keep moving in the event of a technical breakdown, accident, vandalism or even misfuelling, the **Mercedes-Benz mobility package Mobilo³** is included as part of the standard specification. It covers the cost of local assistance, for example for towing your car away or for a replacement vehicle – and will do so in more than 40 countries across Europe for up to 30 years³. Furthermore, for the first four years following initial registration of the vehicle, Mobilo offers special mobility services in the case of workshop visits involving warranty or goodwill situations.

Avoid unexpected workshop costs⁴: a **Mercedes-Benz Service Contract** covers unforeseeable repairs, maintenance or wear parts, depending on the specific contract. Your local Mercedes-Benz dealer will be pleased to provide information about available Service Contracts and terms and conditions.

Mercedes-Benz Financial Services. Drive a Mercedes-Benz and remain flexible when it comes to payment: our attractive leasing and finance products make this possible – matched to your requirements and needs. We will also be happy to offer you a range of detailed insurance proposals. Just speak to your Mercedes-Benz dealer, who will be happy to provide information about our current range of financial services, terms and conditions.

¹ Alternatively: +49 69 95 30 72 77. Calls to a landline are chargeable. ² Calls from a mobile phone to a landline are chargeable. ³ When it expires, (four years after initial registration) Mobilo can be extended to up to 30 years from one service to the next by your authorised Mercedes-Benz service partner. ⁴ Mercedes-Benz service contract terms and conditions apply.

Enjoy the digital experience of Mercedes-Benz – wherever you happen to be. Thanks to a range of offers optimised for smartphones and tablet computers, you can immerse yourself in the world of Mercedes-Benz even while on the move.

Insights into the full product range, a varied programme of entertainment and direct contact to a wide variety of services await you. Take an interactive tour with the **Interactive Owner's Manual**, for example, to get to know your dream car better. Experience the various functions in detail, take a close-up look at what's going on inside or explore the benefits of the particular model on your national Mercedes-Benz website.

With the **"Mercedes-Benz Guides"** app you can also explore the highlights of the various vehicles off-line. The app is available free of charge from the Apple® iTunes® Store (iOS) or the Google Play Store (Android).

Incidentally, our TV and magazine media are also available to watch and read digitally. Explore the whole brand world for yourself at www.mercedes-benz.com. Just click to take a look.

The **fascination of Mercedes-Benz**. A car whose name brings a gleam to the eyes of people all over the world, one that has featured in many a movie and been sung about in international hits, is surely far more than just a car. How did it come to this?

Discover just what has been moving the world for more than 125 years and take a fascinating journey through time as well as through the history of the automobile, in the **Mercedes-Benz Museum**. More than 1500 exhibits over a display area of 16500 square metres demonstrate the unique heritage and innovative power of the inventor of the automobile, among them one-off models such as the oldest Mercedes still in existence, built in 1902, or the legendary "Gullwing" cars. Welcome to a place of innovation: www.mercedes-benz-classic.com/museum

What would the history of Mercedes-Benz be like without **motorsport**? What would motorsport be without Mercedes-Benz? The first vehicle ever to win an automobile race was powered by a Daimler engine. The first Mercedes was a racing car. The Silver Arrows – a true legend. Out of this glorious past has grown an exciting present: the MERCEDES AMG PETRONAS Formula 1 team and the DTM Mercedes AMG C-Coupés fight it out weekend after weekend for points and victory.



Dimensions.

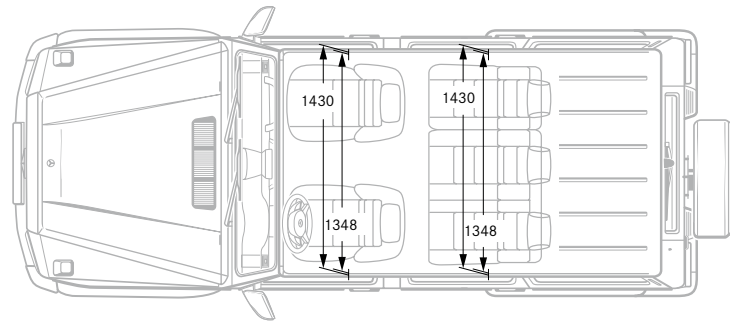
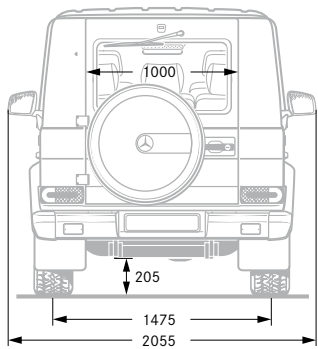
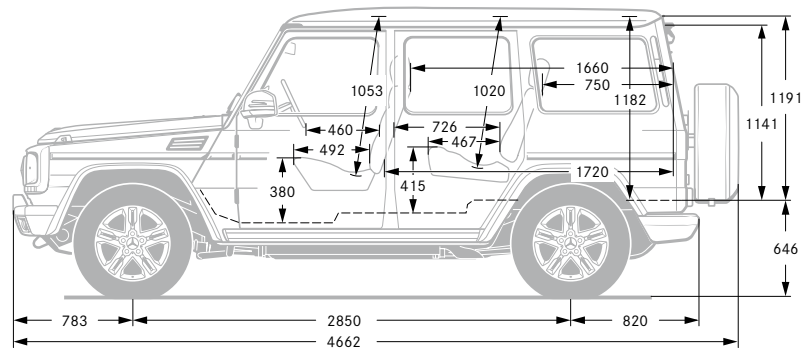
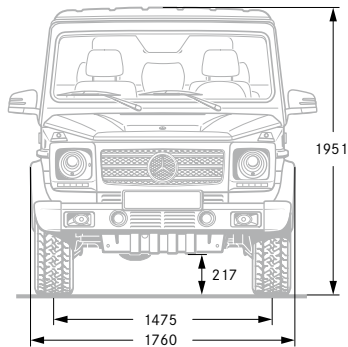

Paintwork.

The paint system developed by Mercedes-Benz includes one of the best clear coats on the automotive market and is a key factor behind the car's excellent value retention. Its secret is the exceptionally thick molecular structure, which makes the metallic or non-metallic clear coat more resistant and produces a longer lasting and visibly more intensive shine.

Technical data.

	Diesel engine	Petrol engines
	G 350 BlueTEC	G 500
No. of cylinders/arrangement	6/V	8/V
Total displacement (cc)	2987	5461
Rated output ¹ in kW (hp) at rpm	155 (211)/3400	285 (387)/6000
Rated torque ¹ (Nm at rpm)	540/1600–2400	530/2800–4800
Compression	17.7	10.7
Transmission	Automatic	Automatic
Acceleration from 0 to 100 km/h (s)	9.1	6.1
Top speed, approx. (km/h)	175	210
Tyres	265/70 R 16	265/60 R 18
Fuel	Diesel	Premium petrol
Fuel consumption ² (l/100 km)		
Urban	13.6	20.0
Extra-urban	9.8	11.9
Combined	11.2	14.9
CO ₂ emissions ² (g/km) combined	295	348
Efficiency class	F	G
Emission class ³	Euro 5	Euro 5
Tank capacity (l)/of which reserve approx.	96/14	96/14
Turning circle diameter (m)	13.6	13.6
Kerb weight ⁴ /perm. GVW (kg)	2570/3200	2530/3200
Perm. towing capacity ⁴ , braked/unbraked (kg)	3500/750	3500/750

¹ Figures in accordance with Directive 80/1269/EEC in the currently applicable version. ² The figures shown were obtained in accordance with the prescribed measuring process (Regulation [EC] 715/2007 in the currently applicable version). The figures are not based on an individual vehicle and do not constitute part of the product offer; they are provided solely for the purposes of comparison between different vehicle models. ³ Figures only valid within the European Union. ⁴ Figures in accordance with Directive 92/21/EC, version 95/48/EC (kerb weight with fuel tank 90% full, driver, 68 kg, and luggage, 7 kg) for standard-specification vehicles. Optional extras and accessories will generally increase this figure and reduce the payload capacity accordingly. ⁵ Changes to Euro 6 in quarter 1/2015. Further technical data can be found at www.mercedes-benz.com

	AMG engines	
	G 63 AMG	G 65 AMG
No. of cylinders/arrangement	8/V	12/V
Total displacement (cc)	5461	5980
Rated output ¹ in kW (hp) at rpm	400 (544)/5500	450 (612)/4300-5600
Rated torque ¹ (Nm at rpm)	760/2000-5000	1000/2300-4300
Compression	10.0	9.0
Transmission	Automatic	Automatic
Acceleration from 0 to 100 km/h (s)	5.4	5.3
Top speed, approx. (km/h)	210	230
Tyres	275/50 R 20	275/50 R 20
Fuel	Premium petrol	Premium petrol
Fuel consumption ² (l/100 km)		
Urban	17.2	22.7
Extra-urban	11.8	13.7
Combined	13.8	17.0
CO ₂ emissions ² (g/km) combined	322	397
Efficiency class	G	G
Emission class ³	Euro 5 ⁵	Euro5 ⁵
Tank capacity (l)/of which reserve approx.	96/14	96/14
Turning circle diameter (m)	13.6	13.6
Kerb weight ⁴ /perm. GVW (kg)	2550/3200	2580/3200
Perm. towing capacity ⁴ , braked/unbraked (kg)	3500/750	3500/750

Non-metallic paints



9040 black



9149 polar white

Metallic paints

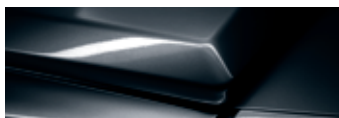

9183 magnetite black



9775 iridium silver



9197 obsidian black

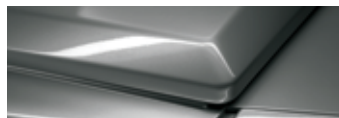

9792 palladium silver



6300 periclase green



8796 citrine brown



5359 tanzanite blue



9963 indium grey



3541 thulite red



9988 diamond silver



7755 tenorite grey

designo manufaktur paints



0033 designo mocha black metallic



0032 designo mystic blue bright



0041 designo graphite metallic



0037 designo mystic red bright



0046 designo platinum black metallic



0052 designo mystic brown bright



0051 designo magno platinum



0056 designo magno night black

Details of further individual designo paint finishes are available from your authorised Mercedes-Benz Dealer.

Take-back of end-of-life vehicles. You can return your G-Class to us for environment-friendly disposal in accordance with the European Union (EU) End-Of-Life Vehicle Directive. But that day lies a long way off.

A network of vehicle take-back depots and dismantlers has been established to make it as easy as possible for you to return your vehicle. You can leave it at any of these points free of charge and, by so doing, make an important contribution to completing the recycling process and conserving resources.

For further information about the recycling and disposal of end-of-life vehicles, and the take-back conditions, please visit the national Mercedes-Benz website.

Please note: Changes may have been made to the product since going to press (31.01.2014). The manufacturer reserves the right during the delivery period to make changes to the design, form, colour or specification, provided these changes, while taking into account the interests of the vendor, can be deemed reasonable with respect to the purchaser. Where the vendor or manufacturer uses symbols or numbers to identify an order or subject of an order, no rights may be derived solely from these. The illustrations may show accessories or optional extras that are not part of the standard specification. Colours may differ slightly from those shown, owing to the limitations of the printing process. This publication may include models and services which are not available in individual countries. Statements about legal and fiscal regulations and effects apply only to the Federal Republic of Germany. Please consult your nearest authorised Mercedes-Benz Passenger Car Dealer about the definitive latest version.

www.mercedes-benz.com