

# LandCruiser 70

Still powerful, still indestructible.



[toyota.com.au](http://toyota.com.au)

  
*Oh what a feeling!*

# Modern, purposeful with legendary strength.

The LandCruiser legend follows a path right back to 1957 and the Snowy Mountains Scheme. It was here the original LandCruiser forged its place in Australian folklore. Then through the years, as the work and demands got tougher, LandCruiser got stronger.

From the Bass Strait pipeline projects to the roughest rural, mining and construction sites, LandCruiser became the 'go to' vehicle you could always count on. Today, LandCruiser 70 Series are the uncompromising workhorses of the LandCruiser line-up. Delivering legendary strength combined with muscled-up looks, stacks of grunt and a truckload of impressive features and comforts inside.



Front cover: Double-Cab Cab-Chassis WorkMate model shown with optional Toyota Genuine tray body  
This page: Single-Cab Cab-Chassis GXL model shown with optional Toyota Genuine tray body





Wagon GXL model shown

## A tough, work hardened physique.

The rugged good looks of the LandCruiser 70 Series are more than just skin deep. The tough steel body is built upon a full steel chassis to provide a strong stable platform.

Not only is the wide body design suitably muscular with real on-road presence, it also accommodates an awesome powerplant up front. And the A-pillar mounted snorkel helps you to breathe easy even when getting in over your head.

That large, impressive looking front bumper is purposely designed to give a great approach angle, so you'll have heaps of clearance when lumbering over tough terrain.

And there's plenty of glass area to maximise visibility and come nightfall, powerful halogen lights show the way ahead. On GXL models, you'll also have fog lamps to clear the way forward in drizzly conditions.



# Shaping up to the challenge.

Regardless of the LandCruiser 70 you choose, you'll have a vehicle purpose built from the ground up to get stuck into the rough stuff.

The practical WorkMate in the Single-Cab and Double-Cab Cab-Chassis models, the Wagon and the Troop Carrier, is fitted with a black front bumper, radiator grill and mirrors. Tough as nails 16" alloy wheels come as standard on the GX Single-Cab and Double-Cab, GXL

Cab-Chassis and Wagon grades. These models also feature over-fender flares and wide mudguards as well as central locking.

A chrome grille, roof drip rails and bumper are all standard on the GXL Single-Cab, Double-Cab Cab-Chassis, Wagon and the Troop Carrier models. These models, as well as Workmate grades, also feature chrome door handles.



Troop Carrier GXL model shown



August 2012 Single-Cab Cab-Chassis GXL model shown

## Comfort right up to the task.

Whether you're doing a long haul behind the wheel or long hours on the tools, the interior features and comforts in LandCruiser 70 will help lighten the load.

The engine immobiliser is standard and helps ensure no-one drives your LandCruiser 70 without the nod from you. The lockable glove box also helps keep your valuables in place.

There's an abundance of common sense with controls right where you need them and the blower and heater unit are integrated into one and placed centrally, for easy access. The standard audio system incorporates an AM/FM tuner, USB audio input for iPod<sup>®1</sup>/MP3<sup>2</sup> players and a MP3 compatible CD

player with Bluetooth<sup>®3</sup> capabilities to keep the music working overtime. In the GXL, you'll also have the luxury of power windows and remote central locking.



# Built to work your way.

With a trusty beast that goes almost anywhere, does almost anything, you'll also appreciate the flexibility to load it the way you need. Across the LandCruiser 70 Series, you'll find versatile seating and cabin arrangements that are designed to handle the demands of many different jobs and situations.

In the Double-Cab Cab-Chassis and Wagon models, you'll have enough room to seat five adults and throw in their gear as well as the dog. And when you need to haul the whole crew up to the coalface, Troop Carriers can carry two, five or a small army of ten people.

Plus the wide opening rear doors on the Wagon and Troop Carrier make it a breeze to load people and heavy gear.



Wagon GXL model shown

Single-Cab Cab-Chassis  
GXL and GX/WorkMate



Double-Cab Cab-Chassis  
GXL/WorkMate



Five Seat Wagon  
GXL/WorkMate



Two, five and ten seat Troop Carrier  
WorkMate, GXL





Single-Cab Cab-Chassis GXL model shown with optional Toyota Genuine tray body





Troop Carrier WorkMate model shown



# Hardened outside, welcoming within.

Even when you're out battling the toughest jobs and terrain, inside you'll find LandCruiser 70 delivers the goods by combining functionality with comfort, as well as being equipped with a host of standard features.

The vinyl seating and vinyl flooring can handle dust and mud and wipe down fast when the rough stuff is done. On the GXL you'll enjoy the extra comfort of fabric seat trim and carpet flooring.<sup>4</sup> Whichever way you go, you'll have luxury of seats offering deep cushioning to help soak up the bumps and reduce fatigue on long hard days.

COLOUR GUIDE	Single-Cab Cab-Chassis			Double-Cab Cab-Chassis		Troop Carrier		Wagon	
	WorkMate	GX	GXL	WorkMate	GXL	WorkMate	GXL	WorkMate	GXL
<b>Interior Seat Trim</b>	Grey Vinyl (LC10)	Grey Vinyl (LC10)	Grey Fabric (FF10)	Grey Vinyl (LC10)	Grey Fabric (FF10)	Grey Vinyl (LB10)	Grey Fabric (FD10)	Grey Vinyl (LE10)	Grey Fabric (FG10)
French Vanilla	•	•	•	•	•	•	•	•	•
Silver Pearl <sup>5</sup>	•	•	•	•	•			•	•
Graphite <sup>5</sup>	•	•	•	•	•			•	•
Merlot Red <sup>5</sup>	•	•	•	•	•			•	•
Vintage Gold <sup>5</sup>	•	•	•	•	•			•	•
Sandy Taupe	•	•	•	•	•	•	•	•	•
Midnight Blue	•	•	•	•	•	•	•	•	•

A. GXL Double-Cab Cab-Chassis (overseas model shown)

B. GXL Wagon shown



A.



B.

# Tough with a tender heart.

LandCruiser 70 Series boasts all the grunt and muscle you need to get into uncharted territory. But it also packs in a heap of advanced features to help get you safely home again.

If called upon, the big, powerful ventilated disc brakes all round are ready to slow things down in a hurry. Plus an Anti-lock Braking System (ABS) is standard across the range.

The collapsible steering column has been designed to help provide protection in real life emergency situations, whilst the side intrusion beams help protect you from side-on collisions. These no nonsense measures are further enhanced by driver and front passenger SRS airbags, as well as Emergency Locking Retractor (ELR) seatbelts for the outer positions in the front cabin that also come standard across the range.

Not forgetting the little ones, Child Restraint System (CRS) upper tether anchors allow the easy fitting of child seats in the five door Wagons.

- A. Side impact beams
- B. Disc brakes
- C. Anti-lock Braking System (ABS)
- D. Rigid frame and body structure

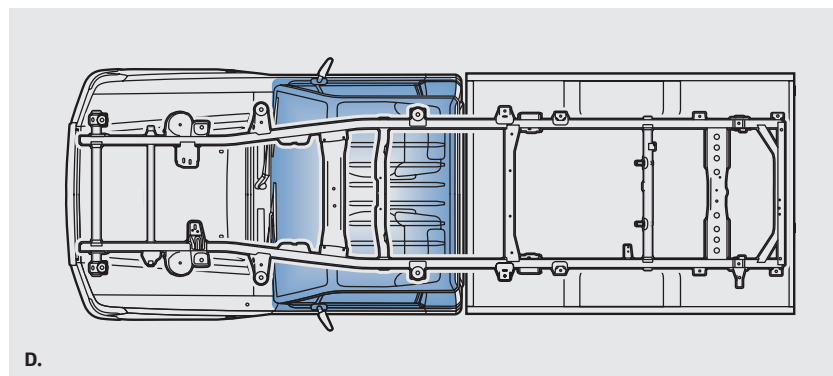
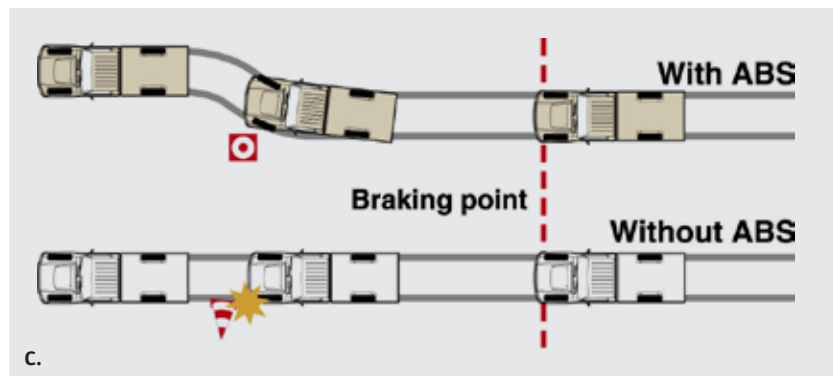
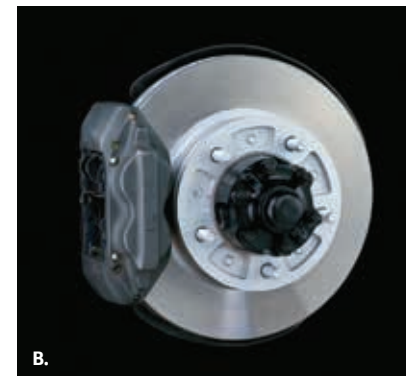
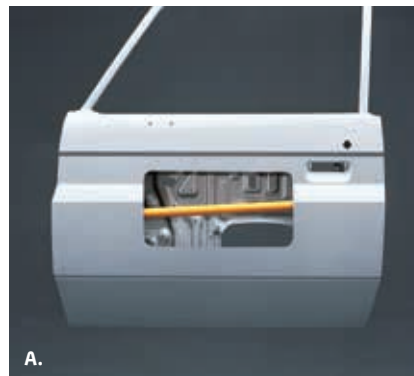



# Real power. No sweat.

A real workhorse needs a big heart, and it'd be hard to find anything with more get-up and go than the LandCruiser 70 Series.

The 4.5 litre V8 Turbo-diesel engine delivers enough grunt to help make tough jobs easy. With 151kW of power coming on strong at just 3,400rpm, and a massive 430Nm of torque all the way from 1,200 – 3,200rpm, you get quick acceleration, big pulling-power on steep hills and muscle to haul heavy loads.

The variable vane turbocharger also provides greater response at lower engine speeds and more power at higher revs. And with the fuel efficiency of just 11.5 litres/100km<sup>6</sup> for the Single-Cab Cab-Chassis and 11.9 litres/100km<sup>6</sup> for the Double-Cab Cab-Chassis, Troop Carrier and Wagon, you're sure to go a long way. Especially with a 180 litre fuel tank available on the Single-Cab Cab-Chassis and Troop Carrier, and the 130 litre tank on the Double-Cab Cab-Chassis and Wagon.

Plus there's the latest fuel injection and technology including Exhaust Gas Recirculation (EGR) to help LandCruiser 70 meet the Euro IV emissions rules.

Then when it comes to harnessing such impressive power, the proven 5-speed manual transmission delivers smoothly across high and low range, even when faced with testing terrain and carrying some heavy loads.



WorkMate Double-Cab Cab-Chassis with optional Toyota Genuine tray shown

# Single-Cab Cab-Chassis



Single-Cab Cab-Chassis GXL model shown with optional Toyota Genuine tray body  
Tray fitted with Under Body Tyre Hanger (Sold separately)

## WorkMate

- 4.5 litre V8 Turbo-diesel engine
- 180L fuel tank
- 5-speed manual transmission
- Power steering
- Halogen headlamps
- 16" steel wheels
- Black front bumper, radiator grille and exterior mirrors
- Steel side steps
- Front mudflaps
- Intermittent windscreen wipers
- Tilt and telescopic steering column
- Engine immobiliser

## GX

- 16" alloy wheels
- Over-fender flares
- Front mudguards
- Multi-function clock

## GXL

- Chrome and painted front bumper
- Chrome radiator grille
- Aluminium side steps
- Power windows
- Central locking/keyless entry
- Variable intermittent wipers
- Front fog lamps



### WorkMate

- 4.5 litre V8 Turbo-diesel engine
- 130L Fuel Tank
- 5-speed manual transmission
- Power steering
- Halogen headlamps
- 16" steel wheels
- Black front bumper, radiator grille and exterior mirrors
- Aluminium side steps
- Front mudflaps
- Intermittent windscreen wipers
- Tilt and telescopic steering column
- Engine immobiliser

### GXL

- 16" alloy wheels
- Chrome and painted front bumper
- Chrome radiator grille
- Multi-function clock
- Front mudguards
- Central locking/keyless entry
- Variable intermittent wipers
- Front fog lamps

## Double-Cab Cab-Chassis



Double-Cab Cab-Chassis GXL shown with optional Toyota Genuine tray body

# Wagon



Wagon GXL model shown

## WorkMate

- 4.5 litre V8 Turbo-diesel engine
- 130L fuel tank
- 5-speed manual transmission
- Aluminium side steps
- 16" steel wheels
- Power steering
- Halogen headlamps
- 4-speaker single CD Audio with manual antenna, Bluetooth,<sup>®3</sup> MP3 and USB/AUX inputs<sup>2</sup>
- Manual window control
- Black front and rear bumpers
- Chrome door handles
- ABS brakes

## GXL

- 16" alloy wheels
- Chrome and painted front and rear bumpers
- Chrome radiator grille
- Power windows
- Differential locks
- Multi-function clock
- Over-fender flares
- Front mudguards
- Front fog lamps



### WorkMate

- 4.5 litre V8 Turbo-diesel engine
- 180L fuel tank
- Steel side steps
- 16" steel wheels
- Power steering
- Barn type rear tailgate with spare wheel
- Engine immobiliser
- Halogen headlamps
- Driver and front passenger airbags
- Available in 2 or 10 seat variants
- ABS brakes
- 12V accessory connector

### GXL

- Chrome and painted front and rear bumpers
- Aluminium side steps
- Front fog lamps
- Power windows
- Cloth seat trim
- Rear bench seat
- 5 seat capacity

# Troop Carrier



Troop Carrier GXL model shown



A.



B.



C.



D.



E.



F.



G.

## Land your perfect colour.

From the red centre, to the bush or down by the sea, the colours of Australia are wonderfully vibrant and varied. And so are the seven knockout colours for LandCruiser 70 Series, ready for you to blend in or stand out from your chosen terrain.

A. French Vanilla 058  
B. Silver Pearl<sup>1</sup> 1F7  
C. Sandy Taupe 4E9  
D. Vintage Gold<sup>3</sup> 4R3

E. Graphite<sup>5</sup> 1G3  
F. Merlot Red<sup>5</sup> 3Q3  
G. Midnight Blue 8H6





Single-Cab Cab-Chassis GXL model shown in Merlot Red, accessorised with Toyota Genuine Steel Bull Bar, Side Rails (Front and side pair), Driving Lights, Headlamp Covers, Front Weathershields and Galvanised Steel Colour-coded Tray Body. All sold separately.



# Accessories for every working environment.

Roll up your sleeves and make your LandCruiser 70 totally job ready with Toyota Genuine Accessories, all developed to perform in the toughest conditions and backed by our Toyota Warranty.<sup>7</sup>

- A. Airbag Compatible Steel Bull Bar, Driving Lights, Superwinch, Bonnet Protector, Headlamp Covers and Side Rails (Sold separately)
- B. Airbag Compatible Steel Bull Bar, Driving Lights, Superwinch, Bonnet Protector and Headlamp Covers (Sold separately)
- C. Side Rails – front and side pair (Sold separately)
- D. Front Weathershields
- E. Sunvisor – unpainted
- F. Cargo Barrier  
Available on Wagon and Troop Carrier models







G.



H.



I.



J.



K.



L.



M.



N.

- G. Heavy Duty Roof Racks – two bar set**  
Available on Wagon and Troop Carrier models (Third bar shown – sold separately)
- H. Heavy Duty Galvanised Steel Tray Body (Colour coded)<sup>8,9</sup>**  
Available on Cab-Chassis models. Tray fitted with Under Body Tyre Hanger (Sold separately)
- I. Heavy Duty Alloy Tray Body**  
Available on Cab-Chassis models. Tray fitted with Under Body Tyre Hanger (Sold separately)
- J. Towbar,<sup>10</sup> Towball and Trailer Wiring Harness**  
Image shown does not include wiring harness (Sold separately)
- K. Alloy Wheel Lock Nut Set**
- L. All Weather Rubber Floor Mats – front**
- M. Satellite Navigation<sup>11</sup> Audio System**
- N. Canvas Seat Covers**

MECHANICAL SPECIFICATIONS		
<b>Engine</b>	Engine	V8 Turbo-diesel
	Name	1VD-FTV
	Displacement (cm <sup>3</sup> )	4461
	Max power (kW/rpm)	151/3400
	Max torque (Nm/rpm)	430/1200-3200
	Valve train	32-valve DOHC
	Fuel system	Common-rail type
	Bore x Stroke (mm)	86.0 x 96.0
	Compression ratio	16.8:1
<b>Transmission</b>	Transmission	5-speed manual
	Gear ratios	1st 4.529; 2nd 2.464; 3rd 1.490; 4th 1.000; 5th 0.881; Reverse 4.313
	Transfer Gear Ratio (H4/L4)	1.000/2.488
	Driveline	4WD
<b>Fuel</b>	Fuel type	Diesel
	Fuel economy <sup>6</sup> (L/100km)	Single-Cab Cab-Chassis: 11.5; Double-Cab Cab-Chassis, Wagon and Troop Carrier: 11.9
	Fuel capacity (litres)	Single-Cab Cab-Chassis and Troop Carrier: 180; Double-Cab Cab-Chassis and Wagon: 130 (additional 90L option for Single-Cab WorkMate)
<b>Steering</b>	Steering system	Hydraulic
	Steering operation	Power steering
	Turning circle (kerb to kerb) (m)	Single and Double-Cab Cab-Chassis: 14.4; Troop Carrier: 13.6; Wagon: 12.6
<b>Brakes</b>	Brake control system	Front and rear ventilated discs
<b>Suspension</b>	Front	Rigid live axle, leading arm, coil springs, dampers and anti-roll bar
	Rear	Rigid live axle, semi-elliptic leaf springs, dampers



LANDCRUISER 70 MODEL		Single-Cab Cab-Chassis			Double-Cab Cab-Chassis		Wagon		Troop Carrier	
		WorkMate	GX	GXL	WorkMate	GXL	WorkMate	GXL	WorkMate	GXL
Dimensions <sup>12</sup> and Weights	Overall length (mm)	5220	5220	5230	5220	5230	4870	4910	5210	5220
	Overall width (mm)	1790	1870	1870	1790	1870	1790	1870	1790	1790
	Overall height (mm)	1970	1955	1955	1960	1945	1955	1940	2115	2115
	Wheelbase (mm)	3180	3180	3180	3180	3180	2730	2730	2980	2980
	Front track (mm)	1515	1555	1555	1515	1555	1515	1555	1515	1515
	Rear track (mm)	1420	1460	1460	1420	1460	1420	1460	1420	1420
	Running clearance (mm)	235	235	235	235	235	230	230	235	235
	Kerb weight (kg) <sup>13</sup>	2065	2065	2075	2205	2215	2295	2295	2340	2355
	Gross Vehicle Mass (GVM) (kg) <sup>14</sup>	3300	3300	3300	3300	3300	3060	3060	3300	3330
Capacities	Seating capacity	2	2	2	5	5	5	5	10 and optional 2 seat	5
	Towing capacity <sup>10</sup> – with trailer brakes	3500	3500	3500	3500	3500	3500	3500	3500	3500
	Towing capacity <sup>10</sup> – without trailer brakes	750	750	750	750	750	750	750	750	750
Wheels	16" steel wheels	•			•		•		•	•
	16" alloy wheels		•	•		•		•		
Exterior	Moulded black front bumper	•	•		•					
	Chrome and painted front bumper			•		•				
	Moulded black front and rear bumpers						•		•	
	Chrome and painted front and rear bumpers							•		•
	Front mudflaps	•	•	•	•	•				
	Front and rear mudflaps						•	•	•	•
	Steel side steps	•	•						•	
	Aluminium side steps			•	•	•	•	•		•
	Halogen headlamps	•	•	•	•	•	•	•	•	•
	Front fog lamps			•		•		•		•

LANDCRUISER 70 MODEL		Single-Cab Cab-Chassis			Double-Cab Cab-Chassis		Wagon		Troop Carrier	
		WorkMate	GX	GXL	WorkMate	GXL	WorkMate	GXL	WorkMate	GXL
<b>Exterior</b> <i>continued</i>	Air-intake snorkel	•	•	•	•	•	•	•	•	•
	Over-fender flares		•	•		•		•		
	Chrome radiator grille			•		•		•		•
	Chrome roof drip rails			•		•		•		•
	Power antenna			•		•		•		•
	Barn type 60/40 rear tailgate doors						•	•	•	•
<b>Interior</b>	Bucket front seats (2 seats)	•	•	•	•	•	•	•	•	•
	Front bucket seats and second row bench seat				•	•	•	•		
	Textured vinyl seat trim	•	•		•		•		•	
	Cloth seat and door trim			•		•		•		•
	Floor carpet			•		•		•		
	Air conditioning	Optional	Optional	Optional	Optional	Optional	Optional	Optional	Optional	Optional
<b>Instruments and Controls</b>	Front and rear power windows					•		•		
	Front power windows			•						•
	Tilt and telescopic steering column	•	•	•	•	•	•	•	•	•
	Intermittent windscreen wipers	•	•		•				•	
	Variable intermittent windscreen wipers			•		•	•	•		•
	12V accessory socket	•	•	•	•	•	•	•	•	•
	Multi-function clock		•	•		•		•		•
	Central locking/keyless entry			•		•		•		•
Differential locks			•		•		•		•	





# The Toyota Advantage.

Every Toyota gives you a lifetime of advantages. That's what makes it a Toyota. You'll enjoy legendary Toyota value from the moment you drive away, and you'll continue to appreciate the quality, safety and innovation that's engineered into each model, every day you drive.



Discover the full range of Toyota products and services and find your nearest Dealer at [toyota.com.au](http://toyota.com.au)



**TOYOTA  
ACCESS**

**A SMARTER WAY TO BUY**

## A smarter way to buy.

Toyota Access puts you in complete control when buying a new car.<sup>15</sup> Drive out of the Dealership with a clear road ahead then drive back a few years later with more options at your disposal than ever before. Whatever stage you're at in life, Toyota Access puts you in the driver's seat with ongoing flexibility and assurance. To discover Toyota Access for yourself visit [toyota.com.au/access](http://toyota.com.au/access)



**TOYOTA  
FINANCE**

**EASY FINANCE OPTIONS**

## Finance to get you going.

If you need a little help, Toyota Finance<sup>18</sup> can offer you a wide range of vehicle financing. With Toyota Finance, you'll have the peace of mind of dealing with one of Australia's leading vehicle finance corporations with over 30 years experience. And with a range of flexible products and services to suit almost every need and circumstance, Toyota Finance can help find the right package for you or your business.



**TOYOTA  
SERVICE  
ADVANTAGE**

**CAPPED PRICE SERVICING**

## Capped price servicing.<sup>16</sup>

A new Toyota means you don't have to worry about unexpected service costs. Every Toyota comes with a low, capped price service cost for a set number of years/kilometres. Pay the same low capped price from one eligible logbook service to the next for up to three years or 60,000km, whichever occurs first (including Genuine parts, labour and fluids). For the full benefits consult a Toyota Dealer or visit [toyota.com.au/advantage](http://toyota.com.au/advantage)



**TOYOTA  
INSURANCE**

**GENUINE TOYOTA COVER**

## Even more protection.

Our Comprehensive Motor Vehicle insurance<sup>19</sup> policy is packed with great benefits including; agreed value cover or New vehicle replacement cover for Toyota vehicles damaged beyond repair within 3 years of original registration, Genuine Parts Promise and Lifetime Repair Guarantee. And our Toyota Insurance Factory Approved Extended Warranty Insurance provides protection that continues after your Toyota New Vehicle Warranty ends.



**TOYOTA  
WARRANTY**

**PEACE OF MIND**

## We've got your back.

Every new Toyota is built to exceptional standards, backed by a three year/100,000km<sup>17</sup> warranty, giving you the peace of mind to feel confident for years to come. In the unlikely event that you need them, every Toyota Service Centre is committed to providing any warranty repairs you may need. They have the technology, the tools, and the skilled personnel to keep your Toyota in excellent condition.



**TOYOTA  
EXTRA CARE**

**PEACE OF MIND**

## Extend your peace of mind.

Whether it's a flat tyre, lost keys or a flat battery, Toyota Extra Care Roadside Assist<sup>20</sup> is never more than a phone call away. Available 24 hours a day, seven days a week, every day of the year, you'll have peace of mind, whatever your emergency. With two levels of cover available, Toyota Extra Care Roadside Assist provides one of the most professional, reliable, and technologically advanced assistance networks in Australia.

# Disclaimers and Notice.

- 1 iPod® is a trademark of Apple, Inc. Not all devices will be compatible and functionality will vary depending on the device.
- 2 Not all devices will be compatible. Functionality varies depending on device.
- 3 The Bluetooth® word mark is owned by Bluetooth SIG, Inc. Not all devices will be compatible and functionality varies depending on the device.
- 4 Troop Carrier GXL comes standard with vinyl rear flooring.
- 5 Paint featured is optional extra at additional cost.
- 6 Fuel consumption varies depending on driving conditions/style, vehicle conditions and options/accessories. Source of fuel consumption data: ADR81/02 combined.
- 7 All Toyota Genuine Accessories purchased and fitted to a Toyota are warranted for the remainder of the New Vehicle Warranty or 12 months, whichever is greater. Toyota Genuine Accessories purchased from an authorised Toyota Dealer over the counter are warranted from the date of purchase for one year. Conditions apply.
- 8 Single-Cab tray shown.
- 9 Towbar shown not available for sale.
- 10 Towing capacity is subject to regulatory requirements, towbar and vehicle design and towing equipment limitations. Ask your Dealer for Toyota Genuine Towbar capacity and availability details.
- 11 Current navigation mapping database encompasses major capital and primary national road networks and offers some coverage in regional areas.
- 12 Vehicle dimension figures are approximate and vary due to options and accessory fitment.
- 13 Kerb, tare and payload weights are nominal and vary depending on options and accessories.
- 14 Gross Vehicle Mass (GVM) is the total permissible combined weight of the vehicle, including occupants, fuel and cargo.
- 15 Terms and Conditions, fees and charges apply. Toyota Access Guaranteed Future Value products are available to approved customers of Toyota Finance, a division of Toyota Finance Australia Limited ABN 48 002 435 181, AFSL and Australian Credit Licence 392536.
- 16 Maximum payable for standard scheduled logbook servicing (normal operating conditions) until first of three years or 60,000km (whichever occurs first), up to the first six services. Excludes Government & Rental vehicles. Contact your Toyota Dealer or go to [toyota.com.au/advantage](http://toyota.com.au/advantage) for other exclusions, eligibility and full details.
- 17 New Vehicle Warranty expires three years from date of first delivery or 100,000km, whichever occurs first. Refer to the warranty conditions. The New Vehicle warranty does not limit and may not necessarily exceed your rights under the Competition and Consumer Act 2010.
- 18 Toyota Finance is a division of Toyota Finance Australia Limited ABN 48 002 435 181, AFSL and Australian Credit Licence 392536.
- 19 Terms and conditions apply. This advice is general in nature and does not take into account your objectives, financial situation or needs. Before making a decision to purchase any of the insurance products you should consider the appropriateness of the advice taking into account your own objectives, financial situation and needs and refer to the current PDS for the relevant product available from participating Dealers, via our website at [toyotainsurance.com.au](http://toyotainsurance.com.au) or by calling 137 200. Toyota Insurance is issued by Toyota Finance Australia Limited ABN 48 002 435 181, AFSL and Australian Credit Licence 392536. The insurer is Aioi Nissay Dowa Insurance Company Australia Pty Ltd ABN 11 132 524 282, AFSL 443540. Our insurance policies do not change or take away your rights under the Australian Consumer Law. Your right to claim under our policies for the benefits covered are in addition to other rights and remedies you have under the law in relation to your vehicle. However, you can choose to make a claim under any of our policies even if you have rights under the law.
- 20 Toyota Extra Care is administered by Toyota Finance, a division of Toyota Finance Australia Limited ABN 48 002 435 181, Australian Credit Licence 392536.

Toyota Genuine Accessories are not applicable to all models/grades. Consider the mass of your load to ensure you will not exceed the maximum allowable individual axle capacity, Gross Vehicle Mass and/or Gross Combined Mass of the vehicle. Refer to the current Accessories brochure or visit [toyota.com.au](http://toyota.com.au) for details on

#### IMPORTANT NOTICE – PLEASE READ:

Toyota Australia uses its best endeavours to ensure this material is correct when published. You must check with your authorised Toyota Dealer when ordering to ensure the vehicle with your chosen specifications, equipment and colour is available and that the vehicle can be delivered within the timeframe suitable to you. When ordering accessories, you must check with your authorised Toyota Dealer to ensure the accessory's design, features and colours are available and will fit your vehicle. Please also consider the mass of your load to ensure you will not exceed the maximum allowable individual axle capacity, Gross Vehicle Mass and/or Gross Combined Mass of the vehicle. Refer to [toyota.com.au/payload](http://toyota.com.au/payload) for further details. Colours displayed here are a guide only and may vary from actual colours due to printing/display processes. Certain accessories when fitted will require the removal of standard equipment.

warranty and [toyota.com.au/vehiclepayload](http://toyota.com.au/vehiclepayload) for details on vehicle payload, to help determine Accessories suitable for your vehicle. Accessory colours shown may vary from actual colour due to the printing process.

Standard equipment may be retained by Toyota Australia. Toyota Australia reserves the right to change, without notice, at any time prices, colours, materials, equipment, specifications and discontinue colours/models. To the extent permitted by law, Toyota Australia will not be liable for any damage, loss or expense incurred as a result of reliance on this material in any way. Distributed nationally (other than in Western Australia) by Toyota Motor Corporation Australia Limited ABN 64 009 686 097, 155 Bertie St, Port Melbourne 3207. Material distributed in Western Australia by or on behalf of Prestige Motors Pty Ltd (for vehicles) and by Eastpoint Pty Ltd (for parts/accessories). Toyota Australia makes no warranties regarding (and will not be liable for) the accuracy of materials distributed in Western Australia. PART NUMBER: TYLC70PACKBRO. PROOF HQ: T2015-000517. PRINTED: MARCH 2015. GT01579.



Wagon GXL model shown