

The SLC Roadster



Mercedes-Benz



This Brochure is prepared by Daimler AG and it predominantly reflects the capabilities and performance of vehicles sold in Europe. Some characteristics, capabilities performance features and optional extras (e.g. towing systems) may not be available or may not apply in Australia or under Australian conditions. The information in this brochure is therefore indicative, illustrative and provided only for guidance and should not be relied on. To obtain current and accurate information on a vehicle and any options applicable to Australia, contact your local authorized Mercedes-Benz dealer.

Return of a blazing star. The new-generation SLC.

The rhythm of the city suddenly seems to accelerate. Now the new-generation SLC sets the pace. Expressive design. Maximum performance. An astonishing engine sound. The air throbs. Everything is prepared for an even more intense driving experience. Open-top or with the roof closed, on the straight or chasing around curves. A sense of wonder has returned.

WONDER IN EVERY FORMAT.



Experience the new SLC in thrilling HD. With the Mercedes-Benz brochure app for the iPad® and with the Digital Owner's Manual from "Mercedes-Benz Guides" for the iPhone®. Both apps feature a host of films and additional content and are available free of charge from the iTunes Store®.

For gripping the world's attention:

2 | Mercedes-AMG SLC 43

fire opal

AMG 10-spoke light-alloy wheels, painted titanium grey with a high-sheen finish, Exclusive nappa leather/DINAMICA microfibre upholstery in black with red topstitching, dark carbon-grain aluminium trim

10 | Mercedes-Benz SLC 300

designo diamond white bright

5-triple-spoke light-alloy wheels, painted tremolite grey with a high-sheen finish, Exclusive nappa leather upholstery in saddle brown, high-gloss black ash wood trim

16 | Mercedes-Benz SLC 300

iridium silver metallic

AMG Line design and equipment line, AMG multi-spoke light-alloy wheels, painted titanium grey with a high-sheen finish, Exclusive nappa leather in bengal red/black, light carbon-grain aluminium trim

56 | Mercedes-AMG SLC 43

obsidian black metallic

AMG multi-spoke light-alloy wheels, painted high-gloss black with a high-sheen finish, upholstery in Exclusive nappa leather/DINAMICA microfibre in black with red topstitching, AMG carbon-fibre trim

For gripping the world's roads:

24 | Mercedes me

28 | Services

32 | Engines

34 | 9G-TRONIC automatic transmission

35 | DYNAMIC SELECT drive programs

36 | Chassis with Adaptive Damping System ADS

37 | Sports exhaust system

38 | Driving assistance systems

39 | Integral safety concept

40 | COMAND Online

42 | Open-air comfort

44 | Panoramic vario-roof with MAGIC SKY CONTROL

46 | Equipment, packages and accessories

54 | Wheels

56 | Mercedes-AMG

66 | Technical data, dimensions, upholstery, trim and paintwork

Turn the sun up loud.

The design of the new SLC works like an amplifier on the synapses and sense of sight. Long nose, short overhangs – the silhouette is muscular and sensationally dynamic when open and closed. Joie de vivre right down the line, starting with a distinctive front with a diamond radiator grille and chrome wing, brilliantly brought to a conclusion by an expressive tail end.





A red Mercedes-Benz SLC is shown from a low-angle, rear-quarter perspective, driving on a cable-stayed bridge. The bridge's cables and towers are visible in the background, and the water below is blurred, suggesting motion. The sky is bright and clear.

Powertraining.

When driving, the new SLC delivers what its design promises: performance par excellence. Sporty to the max, fuel-efficient or comfortable? Everything goes. Five drive programs are available to choose from via the DYNAMIC SELECT Switch. For every mood, for every route.







Love hertz.

A noise becomes a feeling. Listening becomes experiencing. The rich sound of the new sports exhaust system alone is reason enough to open the roof of the SLC. Each drive program has its own soundtrack: emotively appealing and intense, from powerful roaring through to a deep timbre.



The image shows the interior of a Mercedes-Benz SLC convertible. The car is parked on a cobblestone street, and the top is down. The interior features black leather seats with red stitching, a black dashboard with silver accents, and a black center console with a silver gear shifter. The ambient lighting is a vibrant red, highlighting the interior surfaces. The Mercedes-Benz logo is visible on the dashboard and the center console.

Anyone taking a seat in the new SLC immediately shoots to the top. Agility and comfort come together to form an unbeatable team and positively demand you to drive with the top down. After all, the dynamic interior design deserves to be shown. Be it the restyled sports seats or the sports steering wheel with its perforated grip area. Particularly impressively showcased by the ambient lighting, which strikes the right tone of your mood if you wish.

Comfortissimo.

Applause from the eyes.





An unadulterated roadster driving experience with the comfort and suitability for everyday use of a Mercedes-Benz – only the new SLC offers that in this class. If the sun comes out, the fully power-retractable roof goes down at the press of a button – in less than 20 seconds. In the process the boot separator closes automatically on request for the first time: for even more uninterrupted comfort and cabriolet pleasure.

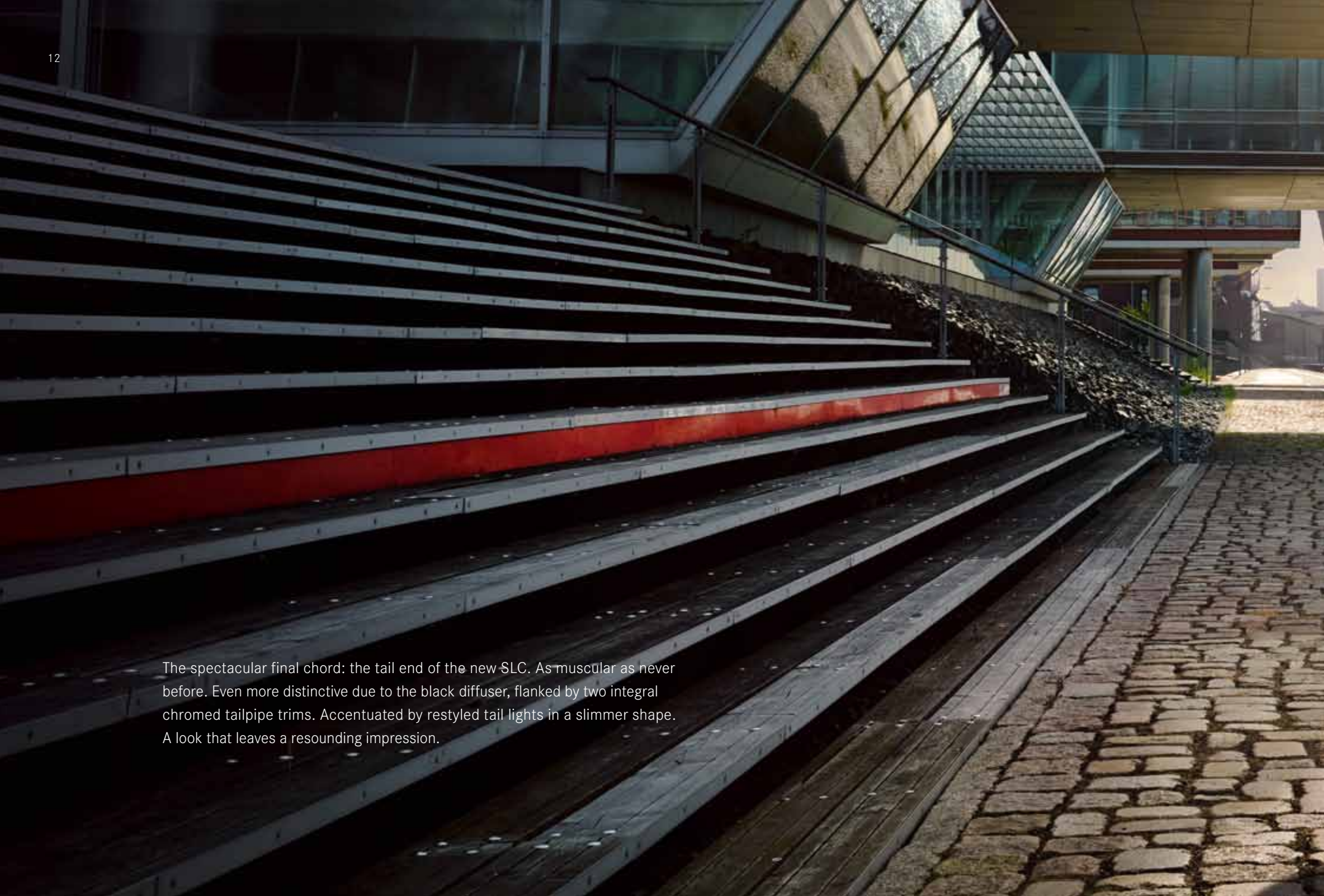

The spectacular final chord: the tail end of the new SLC. As muscular as never before. Even more distinctive due to the black diffuser, flanked by two integral chromed tailpipe trims. Accentuated by restyled tail lights in a slimmer shape. A look that leaves a resounding impression.





Open for storms of enthusiasm.







High-frequency intelligence.

The sun disappears behind the buildings, the city shines in the light of the optional LED High Performance headlamps. The journey begins. The destination: spur of the moment. Thanks to latest-generation multimedia systems, 3D navigation, telephone and internet are just one touch away. Your window to the digital world: the 17.8 cm (7-inch) media display of the optional COMAND Online. A fine outlook indeed.

A blurred night scene of a road with a metal railing and bridge pillars, suggesting motion and vibration. The image is dark with blue and white highlights from the railing and bridge structure. The road surface is wet and reflective, with a yellow line visible. The overall effect is one of dynamic movement and energy.

Sportiness for good vibrations
on every road.



D S LC 1721



The finest connection between sky and street: the panoramic vario-roof. It offers a clear overhead view – for that al fresco feeling even when the roof is closed. On request also with MAGIC SKY CONTROL: at just one press of a button the tinted glass becomes transparent. And the interior feels even bigger.







There can be no finer end to the day.



Our next great innovation revolves around you.

Prepare to be inspired, surprised and thrilled by new services, products and experiences at www.mercedes.me. You are also warmly invited to check out our Mercedes me stores in major cities such as Hamburg, Milan, Tokyo or Hong Kong.





Mercedes me. Welcome to your Mercedes-Benz world.

You have new questions, Mercedes-Benz has a new answer for you: Mercedes me. Your point of access to a fascinating world of personalised services from Mercedes-Benz. Offering innovative, individualised mobility, connectivity, finance and other services, as well as special brand experiences. All subject to continual development. Innovative, simple and cutting-edge: www.mercedes.me

Join us – on your smartphone, tablet or PC. And let's shape tomorrow's world together. Any time, anywhere.

Mercedes me connect is all about networking the vehicle with the driver – and more besides: the car is becoming part of the way we live, providing added comfort as well as the reassurance of being permanently connected, even while on the move. Mercedes me connect includes Standard Services, which are able to provide you with automatic support in the event of a breakdown or an accident, and Remote Online Services – the option enabling vehicle settings to be carried out by smartphone.



Mercedes me finance offers you various routes to your vehicle of choice. Mercedes-Benz Financial Services finds the ideal leasing, financing and insurance solution together with you – tailored to your needs. Our leasing products enable you to drive the latest models at all times while enjoying maximum flexibility, as you pay not for acquisition of the vehicle, but only for its use. You also benefit from attractive monthly instalments. Our financing arrangements enable you to pay for your new Mercedes-Benz in a way that suits your personal budget. You can tailor your monthly instalments to your needs by deciding on an appropriate down-payment and term for your contract. Our individual insurance solutions offer reliable protection for your budget and your vehicle on attractive terms.

Mercedes me inspire offers special brand experiences and an opportunity to engage in an inspiring dialogue. We aim to share our ideas with you and we would like to know your ideas and wishes. So that we can always offer you the best solutions. A community is available to this end, and you will also find a growing range of offerings and experiences which go beyond the traditional vehicle-related topics – from areas such as events, travel and lifestyle.

Mercedes me move offers access to the intelligent mobility solution moovel: this mobility app pools the offerings from various mobility providers to find the ideal route from A to B. car2go is the pioneer and market leader worldwide in free-floating car sharing, and car2go black stands for smartphone-based car sharing with Mercedes-Benz B-Class vehicles. With the mytaxi app you can order a taxi, track its approach live and pay for your journey in a convenient manner.

Mercedes me assist makes easy work of organising maintenance for your vehicle, providing a convenient online means of locating a Mercedes-Benz dealer in your neighbourhood and arranging a service appointment. The digital service report keeps you up to date on performed service work at all times. The report is available to you online just one day after a service. In addition to the current service report, you can also view your vehicle's complete service history and service intervals, and you can print this information out if you so wish.

**Mercedes-Benz
Service**



Our service: the perfect fit for your Mercedes.

Beyond the car itself, you also acquire something priceless – an exclusive partnership with Mercedes-Benz. For you, this means safety, independence and motoring free of any worries. In other words: the reassuring feeling of driving a Mercedes.

The best for your Mercedes. No-one knows your Mercedes better than our experienced specialists at the Mercedes-Benz workshops. The comprehensive range of services and the high standard of quality ensure that your vehicle is in top condition. We use tested Mercedes-Benz GenuineParts and special tools to this end.

The best for you. Motoring free of any worries right from the word go: with the tailor-made Mercedes-Benz Service Contracts. These offer you the benefits of a reliable basis for long-term planning, permanent control over costs, fixed monthly rates and cost transparency. Plus ideal protection from additional workshop costs.

The best for your mobility. The Mercedes-Benz Mobilo¹ insurance package provides for motoring free of any worries throughout Europe – covering breakdowns, accidents, minor mishaps and vandalism. The benefits offered by Mobilo include on-the-spot assistance, a replacement vehicle, towing and overnight hotel accommodation, for example. This mobility guarantee is automatically on board for the first two years after initial registration, and can subsequently be renewed for a period of up to 30 years in all. Whenever you need assistance, you can reach us free of charge throughout Europe on 00800 1 777 7777².

↘ FIND OUT MORE

For the full information on Mercedes-Benz Service Contracts, go to www.mercedes-benz.com/servicevertraege – or ask your authorised Mercedes-Benz dealer to draw up an individual offer for you.

¹ Our general terms and conditions apply. The period of validity is extended after each service carried out by an authorised Mercedes-Benz service partner until the due date for the next service – up to a maximum of 30 years after initial registration. ² Roaming charges may apply when calling from abroad.

What would motorsport be without Mercedes-Benz?

The first vehicle to ever win an automobile race was powered by a Daimler engine. The first Mercedes was a racing car. The Silver Arrows – a true legend. Mercedes-Benz has a long tradition of involvement with the world of sport. Motorsport shapes the brand and every vehicle bearing the Mercedes star to this day. Discover the brand's unique history first-hand: at the Mercedes-Benz Museum in Stuttgart.

↘ FIND OUT MORE

Discover just what has been moving the world for almost 130 years and take a journey through time as well as through the history of the automobile at the Mercedes-Benz Museum. More than 1500 exhibits await you on 16,500 sqm of floor-space, including unique gems such as the oldest surviving Mercedes from 1902 or the legendary gull-wing models.

Welcome to a place of innovation:

www.mercedes-benz.com/museum



What would Mercedes-Benz be without motorsport?

3 June 1934 marked the beginning of the Silver Arrows legend in the International Eifel Race at the Nürburgring. The Silver Arrows works team MERCEDES AMG PETRONAS continued this tradition in the 2014 Formula 1 season. Its successful involvement was crowned by the most impressive double victory of the season, with the team topping both the constructors' and the drivers' rankings. The team's successes are not restricted to the race track, however. Every mile raced also advances the development of hybrid technology for series production.

FIND OUT MORE

Fascinating Formula 1 goes multimedia:

<http://www.facebook.com/MercedesAMGF1>

<http://twitter.com/MERCEDESAMGF1>

<http://www.youtube.com/user/MERCEDESAMGPETRONAS>

<http://plus.google.com/+Mercedesamgf1/posts>

<http://instagram.com/MercedesAMGF1#>

<http://www.MercedesAMGF1.com>



MERCEDES AMG PETRONAS F1 W06 hybrid, 2015 season.



SLC 300

The 4-cylinder petrol engine achieves 180 kW (245 hp) and delivers a maximum torque of 370 Nm.

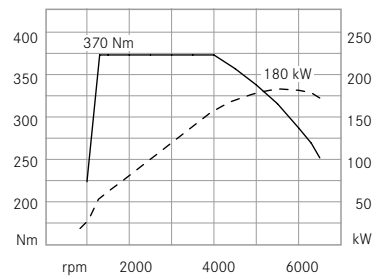

Engine speed rpm

Torque in Nm

Output in kW

The sound of power. The engines.

Powerful. Fast. Superb. Yet very modest with it. Its engines lend the new SLC an inner strength that perfectly complements its captivating looks. The 4-cylinder petrol engines with a displacement of 1.6 and 2.0 l respectively, direct petrol injection, variable valve control and turbocharging are lively and powerful – whilst corresponding to the requirements of the Euro 6 emission class. The combination of the third-generation Mercedes-Benz high-pressure direct injection system with precise piezo injectors and the enhanced spray-guided combustion process facilitates virtually total combustion and thus allows the fuel to be used particularly efficiently. The variable valve control results in an optimum cylinder charge level which has a beneficial effect on fuel consumption and emissions, as do the lower weight and reduced internal friction. For impressive roadster driving enjoyment with no remorse.

Unusual for a roadster – extraordinary for a diesel: the 4-cylinder diesel engine with an output of 150 kW (204 hp) and maximum torque of 500 Nm impresses even in the lower engine speed range. Despite having the performance

of a sports car, its meagre consumption and low CO₂ output make the SLC 250 d one of the most frugal roadsters in the segment. This is made possible by a whole package of intelligent technologies. This fourth-generation common-rail diesel technology engine features an injection pressure increased to 2050 bar, optimised combustion chambers and precise solenoid injectors. High ignition pressure and two-stage turbocharging ensure an effortlessly superior torque curve. The state-of-the-art exhaust gas treatment concept BlueTEC reduces the nitrogen oxide emissions by up to 90 percent.

The impressive top performer in the SLC engine line-up is the new 3.0-litre V6 biturbo engine in the **Mercedes-AMG SLC 43**. An engine so powerful that it deserves its own chapter: find out more from page 56.

For the rare moments when the new SLC stands still: both the diesel and petrol engines have the ECO start/stop function as standard. For yet more efficiency the ECO display supports a consumption-optimised driving style.

THE ENGINE RANGE

Petrol:

SLC 180 with 115 kW (156 hp) output and 250 Nm torque

SLC 200 with 135 kW (184 hp) output and 300 Nm torque

SLC 300 with 180 kW (245 hp) output and 370 Nm torque

Mercedes-AMG SLC 43 with 270 kW (367 hp) output and 520 Nm torque

Diesel:

SLC 250 d with 150 kW (204 hp) output and 500 Nm torque

↳ FIND OUT MORE

From a minimal CO₂ figure to the maximum output: you can find all the technical data on pages 66/67.



Driving desire. 9G-TRONIC and manual transmission.

The new SLC stands for dynamic performance and agility at the highest level. Drivers who enjoy life in the fast lane also need to be able to shift gears quickly, manually or automatically. That's why the power of individual engines is transferred through transmission systems harmonised with the character of each vehicle model.

The **6-speed manual transmission's** hallmark features are ease of shifting and short, direct shift travel. Gear spacing and rear-axle ratio are optimally attuned to the engine output. A display with recommended gear changes on the instrument cluster further encourages a highly efficient driving style.

The **automatic transmission 9G-TRONIC** is a milestone in the field of transmission technology: with nine forward gears, this automatic transmission combines efficiency, comfort and dynamics at an entirely new level. Even faster gear changes and smoother gear shifting make it an enticing proposition. At the same time, 9G-TRONIC helps to reduce fuel consumption. For powerful, fast, short bursts of speed the 9G-TRONIC can skip individual gears when changing down.

DYNAMIC SELECT. One roadster, five powerful personalities.

Motoring pleasure and sportiness are in the very nature of a roadster. With DYNAMIC SELECT the new SLC lives up to this promise in a highly targeted manner, without neglecting comfort or efficiency. In conjunction with the new 9G-TRONIC automatic transmission there are five drive programs available – to suit every mood and every road: Eco, Comfort, Sport, Sport Plus and Individual. For a consumption-oriented, comfortable or decidedly sporty driving style – and the soundtrack to match: from the authentic sports car sound to the subtle long-distance soundscape that lends itself to long journeys. With Individual

you even have at your fingertips a drive program which you can configure yourself to a large extent. You change your drive program via the DYNAMIC SELECT Switch in the centre console. Depending on the setting selected there are model-specific changes to the engine, transmission, sound and steering characteristics. The drive program Sport, for example, offers high agility through adjusted steering support plus modified shift points. The drive program Sport Plus is even more rousing: the drive system and the Adaptive Damping System ADS available on request are configured for maximum dynamism.





A driving masterpiece.

With its sporty tuning the suspension offers an astonishing symbiosis of agility and ride comfort as standard. For an even more sporty driving experience the **Dynamic Handling package with the Adaptive Damping System ADS** is available for selection. The chassis lowered by 10 mm, the Direct-Steer system and the ESP® Curve Dynamic Assist increase agility, ride comfort and directional stability. The damping system has the three basic settings Comfort, Sport and Sport Plus, which can be chosen via DYNAMIC SELECT. On each individual wheel the damping force is continuously and automatically adjusted to the current driving situation.

CHASSIS AND STEERING

The optional 10 mm lower steel **sports suspension** facilitates dynamic driving through its tauter springing and damping configuration.

The **ESP® Curve Dynamic Assist** ensures more stability and handling safety in particular when accelerating in bends. If the ESP® sensors register a tendency towards understeering, this can be reduced through a targeted brake actuation.

The **Direct-Steer system** supplements the comfort of speed-sensitive power steering with a variable steering ratio dependent on the steering angle. This reduces the steering movements when parking and on winding roads leads to more agile vehicle reactions and to more directional stability when driving straight ahead.



The sound for the track. The sports exhaust system.

The new SLC with a **sportily tuned exhaust system** enhances the roadster experience with a spectacular engine sound inside and out. This is made possible by the modified structure of the exhaust silencer system: via the integral exhaust gas flap the sound characteristics adapt to the drive program chosen via DYNAMIC SELECT. Every driving experience is thus given an optimum acoustic backdrop: powerfully increasing and rich when accelerating in the Sport Plus drive program, comfortably restrained during relaxed motoring. The sports exhaust system is installed as standard in the SLC 300 and it is part of the optional AMG Line and the Sports package for the SLC 200.

Plus vision. Minus dangers.

Not only does the new-generation SLC look good – you also see better with it. Because the low-beam headlamps of the optional **LED Intelligent Light System** automatically adapt to the weather, lighting and driving conditions – for better vision on rural roads and motorways, when cornering and on bends. The clearly defined contours and high-quality detailing with a three-dimensional design ensure that the vehicle also has an unmistakable front view in the

daytime too. At night, situation-based light distribution, the light colour similar to daylight and also less glare (compared with a xenon system) ensure maximum visual comfort. Nice gesture: when you unlock your SLC it welcomes you with an extraordinary light show. The optional **Adaptive Highbeam Assist Plus** also proves very obliging: it makes it possible to drive with main beam constantly switched on whilst on unlit roads, without dazzling other road users.

Failure to maintain an adequate distance from the vehicle in front is one of the main causes of serious accidents. The standard **Active Brake Assist** gives the driver a visual warning if the distance to the vehicle in front is too small. If the danger of a collision is detected an acoustic warning signal is emitted; thereafter, the system can support the driver's braking action, and if the driver does not react, the vehicle speed can be autonomously reduced.

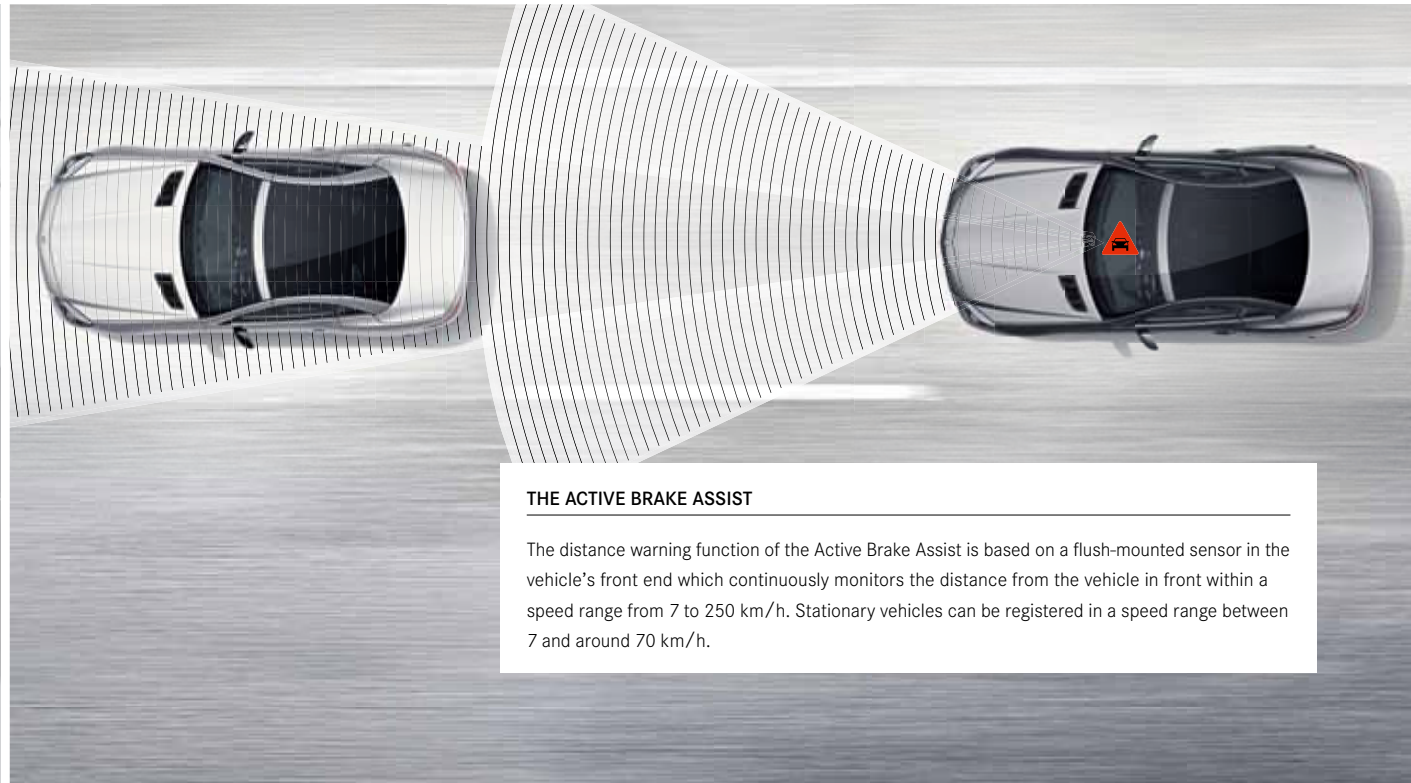

THE ACTIVE BRAKE ASSIST

The distance warning function of the Active Brake Assist is based on a flush-mounted sensor in the vehicle's front end which continuously monitors the distance from the vehicle in front within a speed range from 7 to 250 km/h. Stationary vehicles can be registered in a speed range between 7 and around 70 km/h.

The reassuring feeling of driving a Mercedes-Benz.

We are the first automotive manufacturer worldwide to have developed an **integral safety concept**, aimed at avoiding accidents, ensuring ideal responses to dangers and lessening the consequences of accidents. For the occupants of a Mercedes and for all other road users, too.

SAFE DRIVING

The **ATTENTION ASSIST** can monitor steering behaviour especially on long journeys and at night to detect typical signs of drowsiness and warn the driver of impending microsleep in good time.

The **integral brake system ADAPTIVE BRAKE** improves braking performance through intelligent intervention: in wet conditions, the brake discs are kept dry. The brake pads are applied automatically when the driver's foot is removed abruptly from the accelerator pedal. And on uphill gradients, the system is able to prevent the vehicle from rolling backwards.

The optional **Distance Pilot DISTRONIC** automatically helps the driver to maintain a safe distance from the vehicle ahead and relieves driver strain on long journeys and when following vehicles in a tailback.

The optional **Blind Spot Assist** with radar sensors makes one of the major hazards in traffic visible. When a vehicle is detected in the blind spot, a red triangle lights up in the exterior mirror. An acoustic warning additionally sounds as necessary. The system is active at speeds between 30 and 250 km/h. The optional **Lane Keeping Assist** system is able to detect when the car is unintentionally drifting out of its lane at speeds between 60 and 200 km/h, duly warning the driver by means of vibrations on the steering wheel. Blind Spot Assist and Lane Keeping Assist also form part of the optional Lane Tracking package.

IN THE EVENT OF DANGER

The optionally available preventive **PRE-SAFE® occupant protection system** is able to identify critical driving situations in advance and to initiate precautionary measures to protect the car's occupants if an accident appears imminent. Such measures include reversible belt tensioning or automatic closing of open side windows, for example.

IN AN ACCIDENT

An extensive protection system can significantly reduce the risk of injury. This includes the **active bonnet**, which can automatically rise by six centimetres and thus helps to provide better protection for pedestrians or cyclists. The car occupants, meanwhile, can be supported over a wide area in accidents by up to **six airbags**.

AFTER AN ACCIDENT

Every Mercedes-Benz is optimally trained in first aid. If the worst comes to the worst, the engine can be turned off automatically, the hazard warning lamps and emergency interior lighting can be activated, and the central locking can be unlocked. Finally the **Mercedes-Benz emergency call system** can send position data and important vehicle information, though it is to be hoped this will never be necessary. Over and above this Mercedes-Benz makes Guidelines for Rescue Services available on the internet at www.mercedes-benz.de/rettungsdienst for helpers to download all over the world in different languages.





We hope you enjoy the show.

Conduct the entire world – easily done from your driver's seat. Navigation, telephone, audio, video, internet – with the **COMAND Online** control and display system you are able to keep these and many other functions in view and under control. Information is shown in high resolution and in colour on a 17.8 cm (7-inch) media display. Operation is simple and intuitive. And should you want to hand over the baton now and then: you can use the fast hard-disc navigation with realistic topographic map display for stress-free route guidance.

MULTIMEDIA AND INFOTAINMENT

With COMAND Online a DVD player, radio and interfaces for connecting external devices provide **entertainment made to measure**. Further highlights: the voice-operated control system LINGUATRONIC, Bluetooth® interface with hands-free function, reading function for SMS and music reproduction via audio streaming.

User-friendly navigation, precise map data and excellent route guidance – the **Garmin® MAP PILOT** brings all the familiar benefits of a Garmin® navigation system to the Audio 20 CD – including Live Traffic Information. 3D views plus photorealistic Cross-Traffic and Lane Assistant make orientation easier.

With **Smartphone Integration** it is possible to integrate your iPhone® into the car via Apple CarPlay™ and operate it via voice control – certain functions can also be operated via the vehicle controls. This makes safe use possible while on the move.

**40****SOFT TOP OPERATION WHEN MOVING OFF**

The rain comes down. The comfort continues. Because, if upon moving off the opening or closing procedure of any of the roof variants of the new SLC's vario-roof is initiated, the procedure can be completed at speeds of up to 40 km/h. This means that there are no waiting times for you or the traffic behind you.

Open for every comfort.

Open-top driving in all seasons and almost all kinds of weather: the comfortable, intelligent solutions offered by the new SLC make it possible. For example, the optional **AIRSCARF** neck-level heating developed by Mercedes-Benz extends the open-air season by wrapping an invisible scarf around the shoulders and neck of the driver and passenger. The desired temperature can be adjusted in three levels.

The optional **AIRGUIDE** draught-stop system minimises draughts and air stream noises when driving open-top – thus noticeably enhancing comfort. As it consists of two transparent pivoting elements, it does not restrict visibility towards the rear. These individually adjustable swivelling plastic panels are installed on the rear of the roll-over bars. There they deflect the flow of air so that significantly fewer draughts are generated around the head and neck areas of the passengers.

A particularly comfortable innovation in the SLC is the **partially automatic boot separator**. When the vario-roof is closed this is in the upper position, in order to increase the boot capacity. If the roof is opened, it automatically moves down – manual closing is no longer necessary. The system operates safely: if there are obstacles or if there is a lack of space due to luggage the process is autonomously stopped and the driver is warned.





Ready for the most exciting open-air event of the year?

The new-generation SLC combines the unequalled motoring enjoyment of a roadster with the day-to-day practicality and quiet-running qualities of a coupé. All it takes to open and close the electrohydraulically operated folding **vario-roof** in under 20 seconds is the press of a button. The only question that remains is which roof variant to choose.

The optional **panoramic vario-roof** offers a virtually clear view of the sky even when closed – and makes the car's interior seem lighter and roomier. In conjunction with **MAGIC SKY CONTROL** it provides an open-air feeling at the push of a button even with the roof closed. The glass roof changes its light and energy transmission capability instantaneously. In its tinted state, it substantially reduces heating-up of the vehicle interior.







Powerful. The AMG Line.

The AMG Line emphasises the sportiness and enhances the exclusivity. Impressive features on the exterior include the distinctive AMG bodystyling and AMG 5-spoke light-alloy wheels. The larger, perforated front brake discs improve the car’s performance, while the tauter setting of the sports suspension improves its driving dynamics. In the interior the seats in a sporty design plus red seat belts and contrasting topstitching create a sporty ambience.

EXTERIOR HIGHLIGHTS

- AMG bodystyling, comprising front and rear aprons as well as side sill panels
- AMG 5-spoke light-alloy wheels, painted titanium grey with a high-sheen finish, with 225/40 R 18 front and 245/35 R 18 rear tyres (792)
- Sports suspension lowered by 10 mm (deselectable)
- Diamond radiator grille with chrome pins and chrome-plated louvre
- Larger braking system with perforated brake discs and brake callipers with “Mercedes-Benz” lettering at the front
- Sports exhaust system (SLC 200, standard for SLC 300)

INTERIOR HIGHLIGHTS

- Seats with dynamic sports upholstery layout
- Sports steering wheel with galvanised steering-wheel gearshift paddles in silver chrome (in conjunction with 9G-TRONIC)
- Red contrasting topstitching on seats, steering wheel and armrests on the doors (additional appointments in conjunction with nappa leather/Exclusive nappa)
- Instrument cluster in chequered-flag look
- Red seat belts (can be deselected)
- AMG velour floor mats with “AMG” lettering

➤ PURE AMG

Experience all the fascination of AMG from page 56.



Black magic. The AMG Night package.

Available on request for yet more extravagance and sportiness: the AMG Night package building on the AMG Line. Striking design elements in black underscore the car's sportily expressive character from the front splitter to the exterior mirrors, to the trim strip on the diffuser in high-gloss black.

EXTERIOR HIGHLIGHTS

Diamond radiator grille in chrome with high-gloss black louvre

Front splitter in high-gloss black

High-gloss black diffuser trim strip

AMG 45.7 cm (18-inch) multi-spoke light-alloy wheels painted high-gloss black with a high-shine finish with 225/40 ZR 18 on 8 J x 18 ET43 front axle and 245/35 ZR 18 on 9 J x 18 ET42 rear axle (91R)

Exterior mirror housings in high-gloss black





The standard equipment.

The new SLC leaves virtually nothing to be desired as you take a seat in its standard variant. Numerous extras like the extensive safety equipment, refined comfort features and exclusive details add a special touch to your roadster ex factory.

The **multifunction sports steering wheel**, with a flattened bottom section and in a 3-spoke design in black nappa leather with perforations in the grip area, boasts steering-wheel gearshift paddles in conjunction with 9G-TRONIC.

The **sports seats** give the driver and passenger firm support during extreme lateral acceleration as well, and offer optimal seating comfort on long journeys.

The **climate control system** has a heating and ventilation system as well as a cooling system. A particulate matter activated charcoal filter helps to ensure high air quality.

The **Audio 20 CD** with internet capability, radio, twin tuner, CD drive and Digital Owner's Manual also allows networking with mobile devices via Bluetooth®.

Door sill panels in brushed stainless steel signal exclusive sportiness at first glance.

Main headlamps in H7 projector-beam technology with integral LED daytime running lamps plus Headlamp Assist.

The optional extras.

There is an entire symphony of options for adapting the new SLC to your personal style. From small, fine details for that certain something through to selected, particularly exclusive comfort-enhancing appointments.

The sun-reflecting **Exclusive nappa leather upholstery** stands out with seats, door centre panels, upper part of the dashboard and door beltlines in nappa leather with a cross-piping layout in the appointments colour with piping and topstitching in a contrasting colour.

With the access and drive authorisation system **KEYLESS-GO** (including convenience operation of the vario-roof) the SLC can be opened, started and locked – all just by carrying the electronic key.

The **Harman Kardon® Logic 7® surround sound system** including a 10-channel DSP amplifier and 2-channel booster with a total output of 500 W ensures an unmistakably authentic spatial sound in conjunction with ten high-performance loudspeakers.

The **ambient lighting** showcases the interior with pleasant, indirect light. Solar red, polar blue or polar white: you can select the colour and brightness you prefer.

Navigation, telephone, audio, video, internet – and even your parking space in conjunction with the **reversing camera**: thanks to the 17.8 cm (7-inch) display with TFT technology on the **COMAND Online** control and display system you have an overview of everything.

In addition to their distinctive visual appeal, the **LED High Performance headlamps** boost night-time driving safety thanks to broad light distribution, a daylight-simulating colour temperature, and low energy consumption.

↘ FIND OUT MORE

As attractive as this overview may be, it only provides an initial impression. You can find all the standard equipment and optional extras online at www.mercedes-benz.com





designo. For your very own variation on a theme.

You can hit your personal top note in your new SLC with the exclusive designo paintwork, leather appointments and trim. Carefully chosen materials are turned into genuine masterpieces to the highest standards of craftsmanship. The single- or two-tone characteristic designo leather appointments in designo leather or designo Exclusive leather refine the interior in 21 variants. Matching trim adds individual highlights. Three extraordinary paint finishes are offered for your SLC's show-stopping appearance, including a sensational matt paint.



The **designo upholsteries** in a designo-specific design are available in a single- or two-tone version. Eleven further colour shades are available for combination alongside the base colour black for a personalised and inimitable interior.

The **designo black piano lacquer** trim fundamentally defines the character of the interior and at the same time adds a visual and haptic highlight.

Genuine accessories.

The new SLC leaves virtually nothing to be desired. And for those extra special needs there are genuine accessories. These cover almost every conceivable need for more pleasant and individual motoring. Every accessory has been developed specifically in accordance with Mercedes-Benz's high quality standards.

The **rear spoiler** is harmoniously aligned to the car's contours, reinforcing the sporty design.

5-twin-spoke **light-alloy wheels**, painted palladium silver with a high-sheen finish, with 225/40 R 18 front tyres (see detailed image below left, optionally with 245/35 R 18 rear tyres). Accessory wheels are supplied without tyres.

The 6-part **high-gloss chrome fin attachment** for the air intakes on the bonnet is on the one hand an eye-catching feature and on the other it underscores the sporty character of the new-generation SLC.

↳ **DISCOVER THE ENTIRE RANGE**

Now online at www.mercedes-benz-accessories.com





39R



R49



R35



R93



R23



37R



R81



22R

Wheels.

Wheels are indispensable on practical grounds, of course. But on an emotional level, too, perfect wheels are an absolutely crucial ingredient of many people's dream car. With this in mind, we have put together a particularly large selection for you.

STANDARD EQUIPMENT AND OPTIONAL EXTRAS

39R 10-spoke light-alloy wheels, with 205/55 R 16 tyres (standard equipment for SLC 180)

R23 5-spoke light-alloy wheels, with 205/55 R 16 tyres (standard equipment for SLC 200)

R49 9-spoke light-alloy wheels, with 205/55 R 16 front and 225/50 R 16¹ rear tyres (standard equipment for SLC 250 d)

37R 5-spoke light-alloy wheels, with 225/45 R 17 front and 245/40 R 17 rear tyres (standard equipment for SLC 300)

R35 10-spoke light-alloy wheels, with 225/45 R 17 front and 245/40 R 17 rear tyres (option; not available for Mercedes-AMG SLC 43)

R81 Multi-spoke light-alloy wheels, with 225/45 R 17 front and 245/40 R 17 rear tyres (option; not available for Mercedes-AMG SLC 43)

R93 10-spoke light-alloy wheels, painted palladium silver with a high-sheen finish, with 225/45 R 17 front and 245/40 R 17 rear tyres (option; not available for Mercedes-AMG SLC 43)

22R 5-twin-spoke light-alloy wheels, painted palladium silver with a high-sheen finish, with 225/40 R 18 front and 245/35 R 18 rear tyres (option; not available for Mercedes-AMG SLC 43)

35R 5-twin-spoke light-alloy wheels, painted tremolite grey with a high-sheen finish, with 225/40 R 18 front and 245/35 R 18 rear tyres (option; not available for Mercedes-AMG SLC 43)

¹ Option without an extra charge for for SLC 180, SLC 200 and SLC 300, code R12.



35R



R70



91R



607



47R



792



85R



796

47R 5-triple-spoke light-alloy wheels, painted matt black with a high-sheen finish, with 225/40 R 18 front and 245/35 R 18 rear tyres (option; not available for Mercedes-AMG SLC 43)

R70 5-twin-spoke light-alloy wheels, with 225/40 R 18 front and 245/35 R 18 rear tyres (part of the optional Sports package)

792 AMG 5-spoke light-alloy wheels, painted titanium grey with a high-sheen finish, with 225/40 R 18 front and 245/35 R 18 rear tyres (part of the optional AMG Line)

91R AMG multi-spoke light-alloy wheels, painted high-gloss black with a high-sheen finish, with 225/40 ZR 18 front and 245/35 ZR 18 rear tyres (option; standard equipment for Mercedes-AMG SLC 43 with 235/40 R 18 front and 255/35 R 18 rear tyres)

85R AMG multi-spoke light-alloy wheels, painted titanium grey with a high-sheen finish, with 225/40 ZR 18 front and 245/35 ZR 18 rear tyres (option; for Mercedes-AMG SLC 43 with 235/40 R 18 front and 255/35 R 18 rear tyres)

607 AMG 10-spoke light-alloy wheels, painted high-gloss black, surface with a high-sheen finish, with 235/40 R 18 front and 255/35 R 18 rear tyres (option for Mercedes-AMG SLC 43)

796 AMG 10-spoke light-alloy wheels, painted titanium grey with a high-sheen finish, with 235/40 R 18 front and 255/35 R 18 rear tyres (option for Mercedes-AMG SLC 43)

↘ FURTHER INFORMATION

on the wheels and their availability and on the Mercedes-Benz Genuine Accessories is available from your authorised Mercedes-Benz dealer or at www.mercedes-benz-accessories.com

Conqueror. The Mercedes-AMG SLC 43.

Mercedes-AMG is not just a manufacturer of performance vehicles and sports cars, AMG is a promise. The promise to give everything and always to go one step further. To this end we create extraordinary cars for extraordinary people. With the new Mercedes-AMG SLC 43 we are again underlining our claim to pull out all the stops – in every moment, every metre of the way.

Allow yourself to be enthralled by effortlessly superior power delivery, extraordinary driving dynamics and the good looks and elegance of thoroughbred sports cars which, even at standstill, make it abundantly clear what they are made for: Driving Performance. With 270 kW (367 hp) and 520 Nm the 3.0-litre V6 biturbo engine conquers the roads with impressive output, with the acoustic backdrop of the unique engine sound from the standard-fit AMG sports exhaust system.

Welcome to the world of AMG.





DYNAMISM



A dark grey Mercedes-AMG SLC 43 is shown from a front-quarter perspective, driving on a winding asphalt road through a mountainous landscape. The car's license plate reads 'S LG 4320'. The background features rolling hills and a clear sky with a lens flare effect.

Take possession of the road.

The Mercedes-AMG SLC 43 promises unadulterated driving pleasure. The combination of an updated drive unit offering instantaneous response, the AMG sports suspension and the high-precision, two-stage AMG speed-sensitive sports steering adds up to supremely dynamic performance. Options such as the optional AMG limited-slip rear-axle differential for improved traction in conjunction with the AMG Handling package underscore the claim to the use of cutting-edge racing-sport technology. The 9G-TRONIC transmission system also impresses with its choice of gentle or fast, sporty gear changes. Switch to the “Sport+” mode and experience superbly short response times through double-declutching when shifting down. One tap of the accelerator and the road is yours.





Perfection down to the last detail.

A long bonnet, occupant compartment positioned much further back – the Mercedes-AMG SLC 43 boasts the hallmark attributes of a sports car. The expressive AMG bodystyling is reflected at the front in the steeply raked radiator grille, front splitter in silver chrome and front apron in an A-wing design. In the silhouette the sporty style is continued in details such as the air intakes with fins in silver chrome and AMG 45.7 cm (18-inch) light-alloy wheels. The hallmark AMG pert tail end with its AMG sports exhaust system and chromed tailpipe trims forms the perfect conclusion. This same stylistic consistency is also apparent in the interior. Sports seats covered with nappa leather/DINAMICA microfibre with red topstitching ensure optimum lateral support. One grip of the optional AMG performance steering wheel with a flattened bottom section and red contrasting topstitching – and everything is ready for chasing around curves. It's your move.

Agility and power.



The 3.0-litre V6 biturbo engine of the Mercedes-AMG SLC 43 stands out for its state-of-the-art injection technology and mixture formation, resulting in maximum power combined with low consumption and meagre pollutant emissions. When it comes to Driving Performance the SLC 43 sets new standards in the segment with 270 kW (367 hp) and 520 Nm. The SLC 43 offers two suspension variants: the AMG sports suspension plus the optional AMG RIDE CONTROL sports suspension with damping adjustment. On both versions, all components are designed for high lateral acceleration and reduced body roll. This is exemplified by the substantially reinforced control arm guide bearings and the AMG-specific engine and transmission mounts. The AMG high-performance braking system with internally ventilated and perforated brake discs all round offers maximum control – ensuring superb response and excellent deceleration performance.







Passion grows when it is shared: the AMG Private Lounge is our community centred around the world of AMG. This is where AMG customers meet at top-class events and on the online platform exchange views about the latest developments from Affalterbach. They benefit from special offers and from a direct connection with the AMG headquarters: www.mercedes-amg.com/privatelounge/welcome

The AMG Driving Academy stands for an incomparable team spirit: experience performance with like-minded drivers and improve your driving skills on race tracks and at lifestyle events held at breathtaking locations around the world. Become part of the "World's Fastest Family": www.mercedes-amg.com/driving-academy

You want even more? With the AMG Customer Sports Programme AMG provides a platform for professional motorsport – and with the Mercedes-AMG GT3 its own racing car specially designed for this purpose. A completely integral service world gives you access to motorsport at the highest level: www.mercedes-amg.com/customersports

In the AMG Performance Studio we create cars that are perfectly tailored to your wishes and desires. No limits are placed on our experts' creativity, who demonstrate their unparalleled craftsmanship and attention to detail in areas as varied as special technical components, extravagant paintwork finishes and the most exclusive interior appointments imaginable, to produce one-off masterpieces.

Enter the world of AMG. Experience true Driving Performance.

We don't just build cars.
We make dreams come true.

Technical data.

No. of cylinders/arrangement
Total displacement in cc
Rated output ¹ in kW (hp) at rpm
Rated torque ¹ in Nm at rpm
Transmissions
Acceleration from 0 to 100 km/h in s
Top speed, approx. in km/h
Tyre size – front axle, rear axle
Fuel
Fuel consumption ³ in l/100 km
Urban
Extra-urban
Combined
CO ₂ emissions ³ in g/km combined
Emission class ⁴ /efficiency class ⁵
Tank capacity, of which reserve, approx. in l
Boot capacity in l
With the roof closed
With the roof open
Turning circle diameter in m
Kerb weight ⁶ in kg
Perm. GVW in kg
Length ⁷ /width incl. mirrors ⁷ in mm
Wheelbase ⁷ in mm
Track width front ⁷ /rear ⁷ in mm

DIESEL ENGINE

SLC 250 d

4/in-line
2143
150 (204)/3800
500/1600–1800
– [9G-TRONIC]
– [6.6]
– [245]
205/55 R 16, 225/50 R 16
Diesel
– [5.5–5.2]
– [4.2–3.9]
– [4.7–4.4]
– [123–114]
Euro 6/– [A+]
60/8.0
285
180
10.52
– [1605]
– [1905]
4133/2006
2430
1558/1548

PETROL ENGINES

SLC 180

4/in-line
1595
115 (156)/5300
250/1200–4000
6-speed, manual [9G-TRONIC]
7.9 [8.1]
226 [223]
205/55 R 16
Premium petrol
7.7–7.4 [7.7–7.3]
4.9–4.5 [5.2–4.7]
5.8–5.6 [6.1–5.6]
134–127 [139–128]
Euro 6/B [B]
60/8.0
335
225
10.52
1435 [1460]
1750 [1775]
4133/2006
2430
1559/1565

SLC 200

4/in-line
1991
135 (184)/5500
300/1200–4000
6-speed, manual [9G-TRONIC]
7.0 [6.9]
240 [237]
205/55 R 16
Premium petrol
8.8–8.1 [7.9–7.5]
5.4–4.9 [5.2–4.7]
6.6–6.1 [6.1–5.7]
154–142 [143–133]
Euro 6/C [B]
60/8.0
335
225
10.52
1455 [1480]
1770 [1795]
4133/2006
2430
1559/1565

Figures in square brackets refer to engines with an automatic transmission.

The best for the engine:
Mercedes-Benz genuine engine oils.

¹ Figures for rated output and rated torque in accordance with Directive (EC) no. 595/2009 in the currently applicable version (EC) No. 595/2009. ² Electronically governed. ³ The figures shown for fuel consumption and CO₂ emissions were obtained in accordance with the prescribed measuring processes (§2 nos. 5, 6, 6a of the German Ordinance on Fuel Consumption Labelling (EnVKV) in the currently applicable version). The figures are not based on an individual vehicle and do not constitute part of the product offer; they are provided solely for purposes of comparison between different vehicle models. ⁴ Valid only within the European Union. ⁵ Determined on

PETROL ENGINES

	SLC 300	Mercedes-AMG SLC 43
No. of cylinders/arrangement	4/in-line	6/V
Total displacement in cc	1991	2996
Rated output ¹ in kW (hp) at rpm	180 (245)/5500	270 (367)/5500-6000
Rated torque ¹ in Nm at rpm	370/1300-4000	520/2000-4200
Transmissions	- [9G-TRONIC]	- [9G-TRONIC]
Acceleration from 0 to 100 km/h in s	- [5.8]	- [4.7]
Top speed, approx. in km/h	- [250] ²	- [250] ²
Tyre size - front axle, rear axle	225/45 R 17, 245/40 R 17	235/40 ZR 18, 255/35 ZR 18
Fuel	Super Plus petrol	Super Plus petrol
Fuel consumption ³ in l/100 km		
Urban	- [7.8-7.5]	- [10.7]
Extra-urban	- [5.2-4.7]	- [6.2]
Combined	- [6.2-5.8]	- [7.8]
CO ₂ emissions ³ in g/km combined	- [144-134]	- [178]
Emission class ⁴ /efficiency class ⁵	Euro 6/- [B]	Euro 6/- [D]
Tank capacity, of which reserve, approx. in l	60/8.0	70/9.0
Boot capacity in l		
With the roof closed	335	335
With the roof open	225	225
Turning circle diameter in m	10.52	10.52
Kerb weight ⁶ in kg	- [1505]	- [1595]
Perm. GVW in kg	- [1820]	- [1890]
Length ⁷ /width incl. mirrors ⁷ in mm	4133/2006	4143/2006
Wheelbase ⁷ in mm	2430	2430
Track width front ⁷ /rear ⁷ in mm	1551/1568	1551/1566

the basis of the measured CO₂ emissions taking into account the mass of the vehicle. ⁴ Figures in accordance with Directive 92/21/EC in the currently applicable version version (kerb weight with fuel tank 90% full, driver, 68 kg, and luggage, 7 kg) for standard-specification vehicles. Optional extras and accessories will generally increase this figure and reduce the payload capacity accordingly. ⁷ The dimensions given are mean values. They apply to unladen standard-specification vehicles. You can find further technical data at: www.mercedes-benz.com

Dimensions.

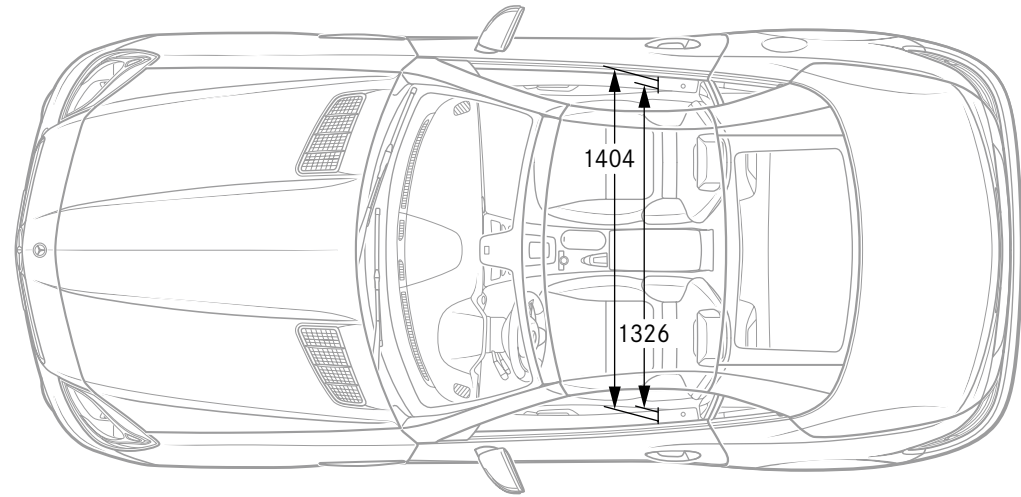
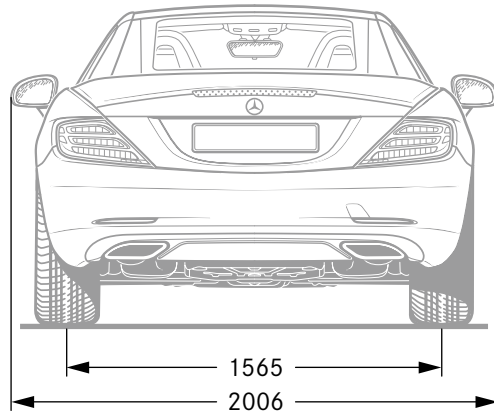
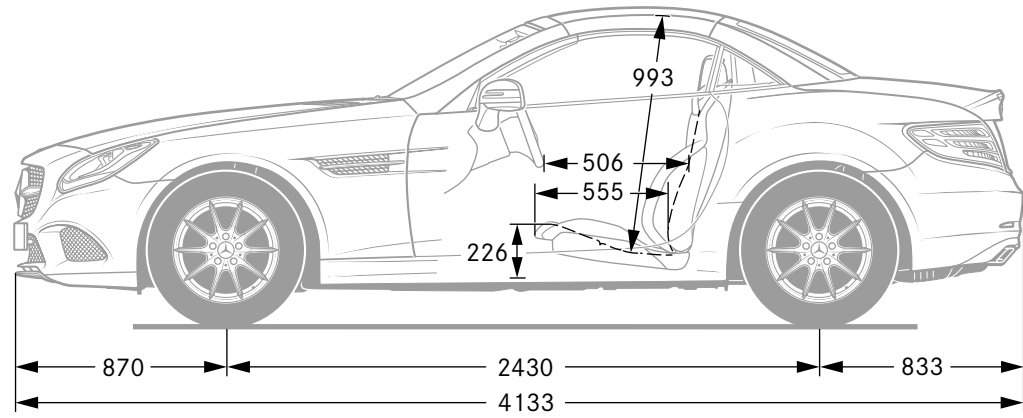
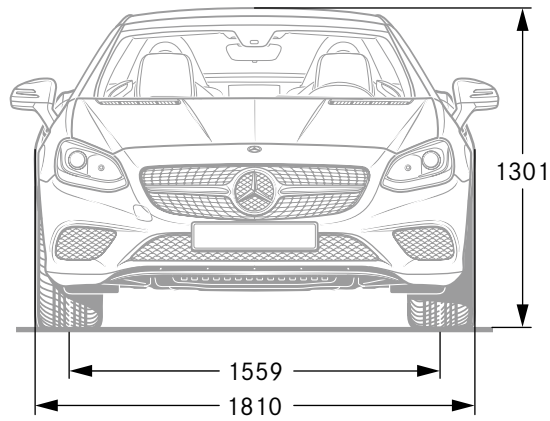

All dimensions in millimetres. The dimensions shown are mean values and apply to standard-specification, unladen vehicles.

Upholstery and trim.



**Fabric
Leather**

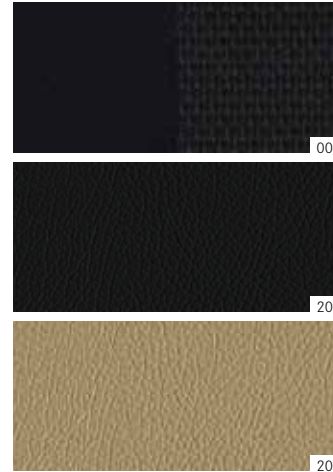

**Nappa leather
Exclusive nappa leather**

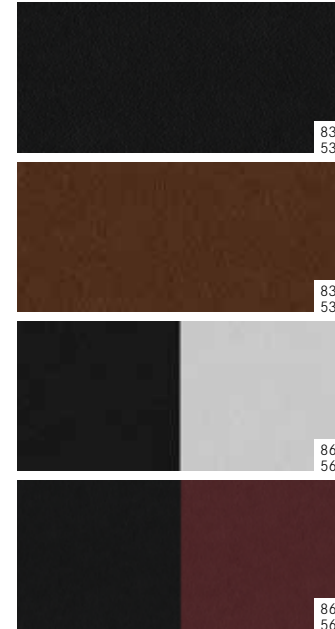

**Leather
Nappa leather; Exclusive nappa leather**

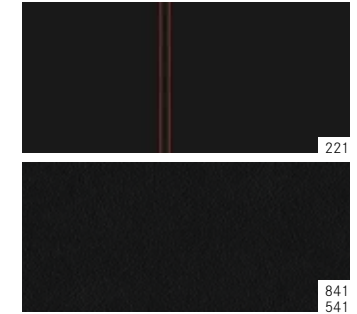

Upholstery			
001	black fabric	X10	designo sand
201	black	X12	designo pastel yellow
205	sahara beige	X17	designo classic red
221	black with red contrasting topstitching ¹	X27	designo porcelain
531	black	X30	designo platinum white
534	saddle brown	X35	designo light brown
541	black ²	X39	designo deep black
565	platinum white pearl/black	X41	designo red pepper
567	bengal red/black	X42	designo curcuma
711	black with red contrasting topstitching ¹	X46	designo deep white
721	black with red contrasting topstitching ¹	X51	designo red pepper/black
751	black with red contrasting topstitching ³	X52	designo curcuma/black
761	black with red contrasting topstitching ³	X60	designo platinum white/black
771	black with red contrasting topstitching ³	X63	designo light brown/black
831	black	X72	designo deep white/black
834	saddle brown	X77	designo sand/black
841	black ²	X78	designo pastel yellow/black
865	platinum white pearl/black	X83	designo classic red/black
867	bengal red/black	X87	designo porcelain/black
X06	designo marron	X96	designo marron/black
Trim			
731	High-gloss brown burr walnut wood		
736	High-gloss black ash wood		
H73	AMG carbon-fibre trim		
H74	Dark carbon-grain aluminium		
H78	Light carbon-grain aluminium		
W69	designo black piano lacquer		

¹ Only in conjunction with AMG Line/Sports package. ² Only in conjunction with AMG Line/Sports package and for Mercedes-AMG SLC 43. ³ Only for Mercedes-AMG SLC 43. ⁴ Either single- or two-tone.



Nappa leather/DINAMICA microfibre
Exclusive nappa leather/DIN. microfibre

designo leather⁴
designo Exclusive leather⁴

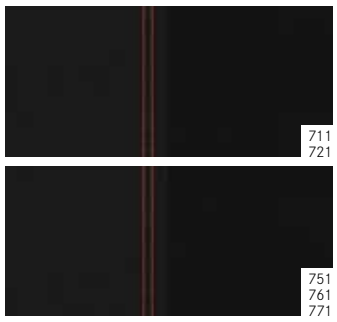

Trim

designo trim

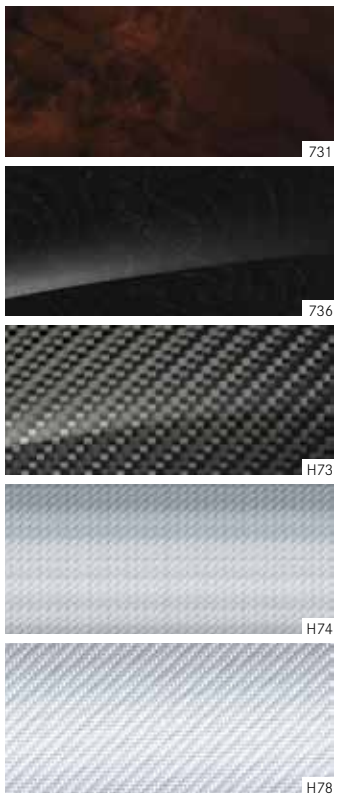

Paintwork.

Non-metallic paints



040

Metallic paints¹



197

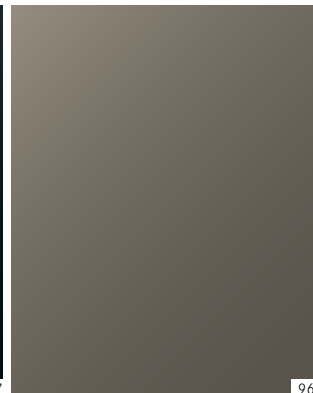

963

designo paints¹



281

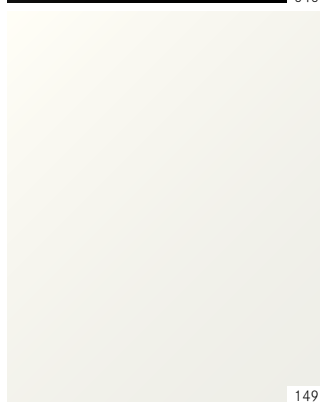

149



775



988



799

Non-metallic paints

- 040 black
149 polar white
590 fire opal

Metallic paints¹

- 197 obsidian black
775 iridium silver
896 brilliant blue
963 indium grey
988 diamond silver
992 selenite grey

designo paints¹

- 281 designo cerussite grey magno
799 designo diamond white bright
996 designo hyacinth red metallic
-

¹ Optional extra.
Additional individual designo paint
finishes are available from your Mercedes-Benz dealer.



590



896



992



996



Mercedes-Benz is one of the founding partners of the “Laureus Sport for Good Foundation”.

Since the foundation was established in 2000, Mercedes-Benz has been supporting and promoting the aims and values of this worldwide non-profit-making programme: to use social sports projects to improve the lives of children and young people who are disadvantaged or suffering from illness. Laureus has become a fundamental element of Mercedes-Benz’s social responsibility. Every new Mercedes is an ambassador embodying these values. In buying a Mercedes you are supporting the “Laureus Sport for Good Foundation”.

Please note: changes may have been made to the product since this brochure went to press (18.11.2015). The manufacturer reserves the right to make changes to the design, form, colour and specification during the delivery period, provided these changes, while taking into account the interests of the vendor, can be deemed reasonable with respect to the purchaser. Where the vendor or the manufacturer uses symbols or numbers to describe an order or the subject of an order, no rights may be derived solely from these. The illustrations may show accessories and items of optional equipment which are not of standard specification. Colours may differ slightly from those shown in the brochure, owing to the limitations of the printing process. This brochure is distributed internationally. It provides a general indication of the range of models, features, optional extras, colours and/or services available in various countries. Some of the models, features, optional extras and/or services shown may not be available in your country or may only be available in a different specification. Additionally some models, features, optional extras, colours and/or services may only be available in combination with others. For current and more specific information in relation to the range of models, features, optional extras, colours and/or services available in your country, and their pricing, you should contact your nearest authorised Mercedes-Benz Passenger Car Dealer.

www.mercedes-benz.com

Take-back of end-of-life vehicles. You can return your SLC to us for environment-friendly disposal in accordance with the European Union (EU) End-Of-Life Vehicle Directive. But that day lies a long way off.

A network of vehicle take-back depots and dismantlers has been established to make it as easy as possible for you to return your vehicle. You can leave it at any of these points free of charge and, by doing so, make an important contribution to completing the recycling process and conserving resources.

For further information about the recycling and disposal of end-of-life vehicles, and the take-back conditions, please visit the national Mercedes-Benz website.