

HiLux  
Unbreakable.



**TOYOTA**



[toyota.com.au](http://toyota.com.au)



*Oh what a feeling!*





## Rock solid refinement.

The nation's favourite WorkHorse is made to be more Unbreakable than you could ever imagine.

Every HiLux begins with an uncompromisingly tough and proven DNA that's the result of over

40 years of continuous testing and development by Toyota in the harshest Australian conditions and terrain. Each is built from the ground up, starting with an extra strong high tensile steel frame featuring hundreds of spot welds to deliver a muscled-up body with exceptional strength and torsional rigidity. Together they mean HiLux is unmatched when it comes to proven performance in the toughest real world situations.

Plus with greater ride comfort and outstanding interior features and appointments, you'll discover the tough HiLux DNA is more refined than ever before.

Front cover: SR5 Hi-Rider Double-Cab Pick-up Turbo-diesel in Olympia Red.<sup>1,2</sup> This page: 4x4 SR5 Double-Cab Pick-up Turbo-diesel in Nebula Blue<sup>1,2</sup> shown accessorised with Toyota Genuine Towing Kit6 (Towbar, Towball and Trailer Wiring Harness sold separately) and Hard Tonneau Cover. All accessories sold separately. Fresh water crossing shown.



# Modern, masculine and undeniably tough.

With its wide stance and imposing presence, HiLux looks every part the powerful all-rounder.

Purposely designed to make it easier to load and handle the hardest jobs, then be more than welcoming when it's time to head out on the town.

From the chunky front bumpers and contrasting grille, through to the dynamic running lines, muscular integrated wheel flares on wide body models, and 18" alloys on SR5, HiLux takes toughness into a fresh dimension.

Up ahead, halogen headlamps and Daytime Running Lamps (DRLs) show the way, rising to

LED low beam headlamps and Daytime Running Lamps on SR5 models.

Depending on the demands of your crew, you can choose from Single-Cab, Extra-Cab or Double-Cab body types in a mix of 4x2 and 4x4 configurations that add up to 31 variants in the HiLux range. Step into the Hi-Rider, and you'll appreciate the raised heavy duty suspension and underbody protection of a 4x4 with the everyday simplicity of a 4x2, while all Extra-Cab models have the added functionality of easy opening rear access doors.



4x2 WorkMate Single-Cab Cab-Chassis in Glacier White shown with optional Toyota Genuine Tray Body.

Unbreakable outside, unforgettable within.



4x4 SR5 Double-Cab Pick-up Turbo-diesel automatic interior shown



Even with its uncompromisingly tough exterior, HiLux provides you with unrivalled levels of interior style within. You could easily mistake the interior for a well-appointed SUV rather than a tough as nails WorkHorse.

Such unprecedented levels of interior style and advanced technology features are matched with a superior ride quality and enhanced quietness to deliver a more than welcoming experience across the entire HiLux range. In 4x4 Double-Cab Turbo-diesel, the optional Leather Accented interior adds an extra touch of sophistication.

Inside you'll always be cool on even the hottest days with air conditioning fitted as standard on every HiLux, rising to single-zone climate control in the SR5. Smart Entry and Start system also allows you to get in and get going while the key stays in your pocket on SR5 models.

When it comes to great sound, the AM/FM display audio system with CD player, including USB,<sup>1</sup> AUX and Bluetooth<sup>2</sup> connectivity, is sure to keep you rocking, rising to six speaker sound in the Double-Cab SR and Double-Cab SR5.

Once underway, the 4.2" Multi Information Display (MID) on SR5 provides you with important trip and vehicle information including outside temperature and average fuel consumption levels. Plus with an integrated Satellite Navigation<sup>3</sup> unit on SR5, you'll go straight to your next project or destination with a minimum of fuss.

- A. Front air conditioned cooler box – SR and SR5 only
- B. 60/40 split rear seat – SR and SR5 Double-Cab only
- C. Satellite Navigation<sup>3</sup> and audio display – SR5 only
- D. Engine start stop button – SR5 only
- E. Single-zone climate control – SR5 only



# Off-road or on the job, HiLux is up to the task.

Unbreakable can now take you further than ever before. Every HiLux has been specially developed and tuned to handle the demands of Australian roads, whether they're in town or well off the beaten track.

The redesigned underbody protection on all Hi-Rider and 4x4 variants is built to be strong, durable and Unbreakable. The special anti-corrosion undercoating makes it ready to meet the demands of harsh working environments and the extra thick construction is perfect to handle and help deflect loose debris to add an extra level of toughness.

The suspension has been extensively tested in Australia, then configured to provide an impressive 520mm of wheel articulation ensuring off-road performance in even the harshest conditions. An approach angle of up to 31° and departure angle of up to 26° on 4x4 variants means that HiLux will go further when the terrain gets tricky. And with incredible ground clearance and a transfer switch that allows you to quickly balance the drive to suit

the conditions, you'll be able to comfortably tackle Australia's toughest terrain.

Hill-start Assist Control<sup>4</sup> (HAC) automatically applies the brakes on steep slopes to help prevent rollback when starting to move forward. On slippery or uneven surfaces, Active Traction Control (A-TRC) optimally delivers the drive force to the wheels with the best grip to provide outstanding ground covering capability. On SR5 4x4 automatic, Downhill Assist Control<sup>5</sup> (DAC) automatically maintains low speed control when driving down steep, slippery and bumpy slopes.

Then when it's time to take charge of a heavy load, the HiLux towing capacity<sup>6</sup> is up to an impressive 3.5 tonnes on Turbo-diesel 4x4 variants, even in off road conditions, and selected variants can shoulder up to a hefty 1240kg payload with ease.

Beefed up and ready to go, HiLux is ready for any challenge, whether it's a hard day's work or your next great adventure.

- A. Front double-wishbone – 4x2 suspension shown
- B. Front double-wishbone – 4x4 and Hi-Rider suspension shown
- C. Heavy-duty rear leaf suspension – 4x4 and Hi-Rider shown
- D.
- E.



A.



B.



C.

Without Hill-start Assist Control



With Hill-start Assist Control

**Hill-start Assist Control<sup>4</sup> (HAC)**

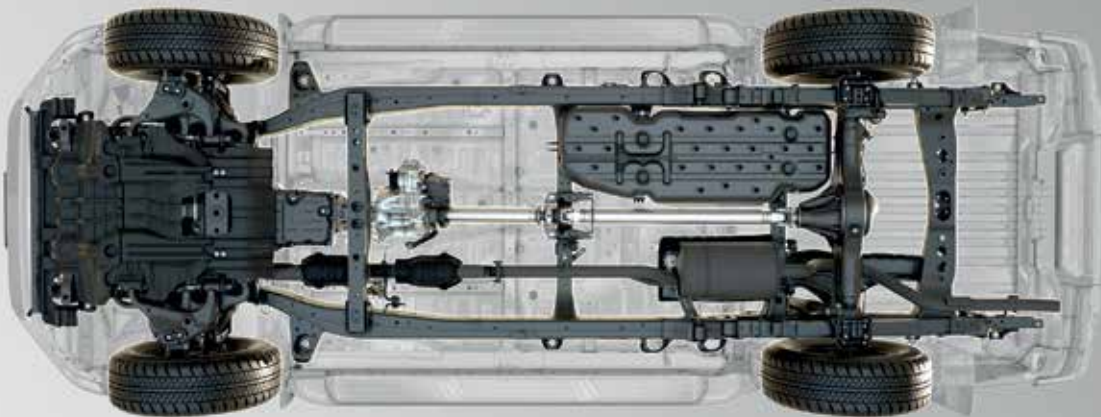

**4x4 and Hi-Rider<sup>4</sup> underbody protection**

Without Downhill Assist Control



With Downhill Assist Control

**Downhill Assist Control<sup>5</sup> (DAC)** – On 4x4 SR5 automatic only



**4x2 underbody protection**

# Toughness with plenty of heart.

Whatever the situation demands, with HiLux you'll always have the power to get the job done.

The 2.4L Turbo-diesel is available on HiLux WorkMate models and delivers up to 400Nm of torque and fuel efficiency as low as 7.1L/100km.<sup>8</sup>

On automatic SR and SR5 HiLux models, the 2.8L Turbo-diesel pumps out a grunty 450Nm of pulling power with manual transmission fuel efficiency as low as 7.3L/100km,<sup>8</sup> making this the strongest, most powerful Turbo-diesel HiLux engine.

More than just numbers, this engine has been developed to produce the maximum torque at the lowest possible RPM. This means the power is always delivered smoothly, giving it outstanding drivability off road or under load conditions. And it's then matched with a drive train that's engineered to deliver all that raw power intelligently.

If you prefer the power of a Dual VVT-i Petrol engine, the 2.7L version is available on the 4x2 WorkMate and delivers 122kW of power using as low as 10.4L/100km.<sup>8</sup> Available on select Double-Cab 4x4 and 4x2 variants, the 4.0L VVT-i V6 can provide you with an impressive 175kW of responsive power.

The intelligent Manual Transmission (i-MT) is now standard on SR5 Turbo-diesel HiLux models. This revolutionises manual gear selection by automatically setting the optimal engine revs to allow the smoothest possible gear changes, whether up or down and helps make it virtually impossible to stall, in even the most critical situations.

On other models you have the choice of a 6-speed automatic, 6-speed manual transmission or 5-speed manual transmission that have been optimised to provide the smoothest possible drive using gear ratios that make the best use of the available power in all conditions and ultimately place less stress on the engine.

A. 4.0L VVT-i Petrol engine  
B. 2.8L Turbo-diesel engine



A.



B.





A.

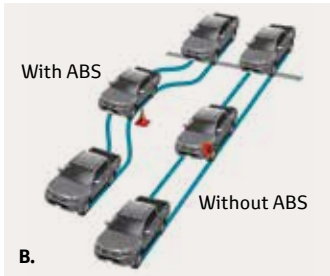

B.

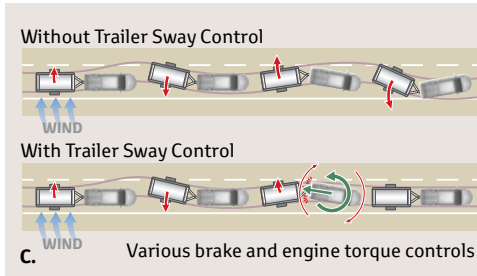

C.

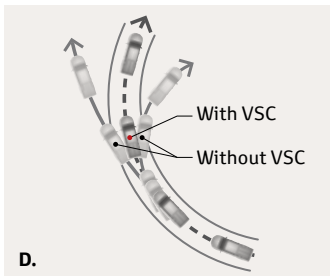

D.



E.

# Tough enough to care.

Whether you're heading to a job, or onto the open road, you'll have the peace of mind of knowing HiLux has the maximum 5-star ANCAP safety rating.

Seven SRS airbags, including side, curtain and a driver's knee airbag, are standard across the range. The Reversing Camera<sup>9</sup> is fitted standard on HiLux pick-up variants with a display that features static guidelines to help make reversing into tight spaces not only safer, but easier too.

The intelligent Anti-lock Braking System (ABS) with Electronic Brake-force Distribution (EBD) helps you stop quickly and safely, while Traction Control (TRC) and Vehicle Stability Control (VSC) help you maintain grip on slippery surfaces and help provide greater control when cornering.

3-point seatbelts with Emergency Locking Retractors (ELR) are standard on each seat and seatbelt reminders are fitted to all front seats and rear seats in Double-Cab variants.

On all variants, Trailer Sway Control (TSC) automatically uses brake and engine output to help limit trailer movement should it experience excessive sway due to cross winds, variable road surface or steering changes by the driver.

- A. Seven SRS airbags – Overseas model shown
- B. Anti-lock Braking System (ABS)
- C. Trailer Sway Control (TSC)
- D. Vehicle Stability Control (VSC)
- E. Child restraint anchor

# A HiLux built for every need.

4x2 HiLux Model	Engine Type	Transmission	Cab	Style
-----------------	-------------	--------------	-----	-------

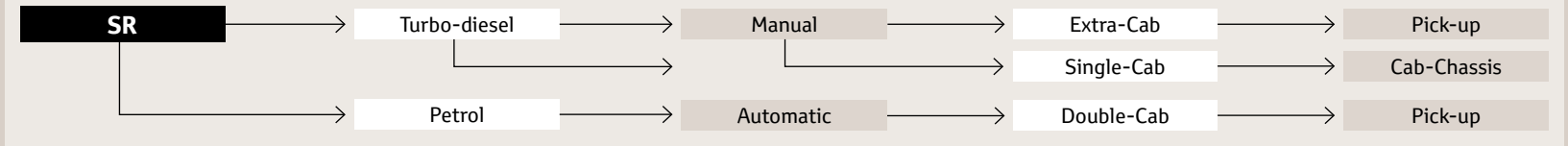
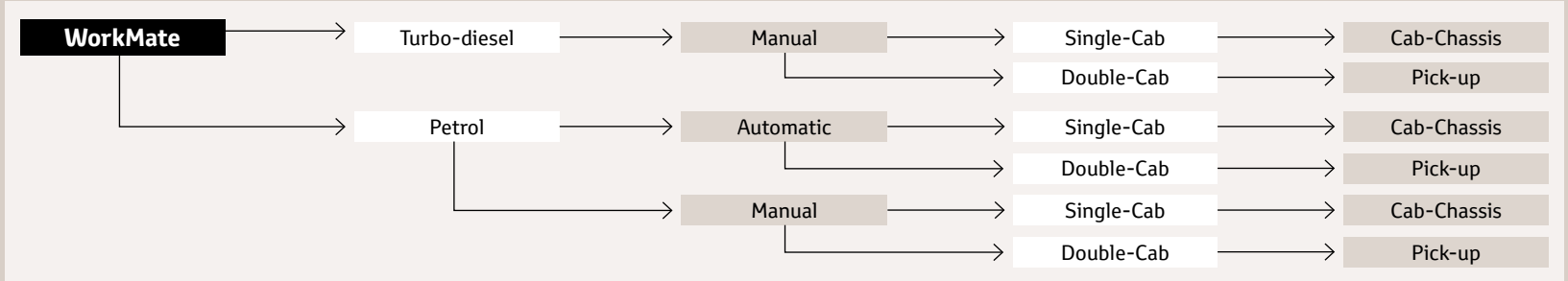

Hi-Rider HiLux Model	Engine Type	Transmission	Cab	Style
----------------------	-------------	--------------	-----	-------

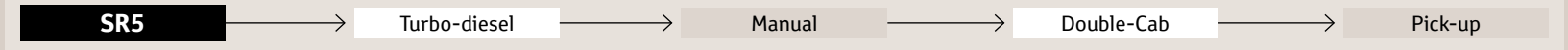
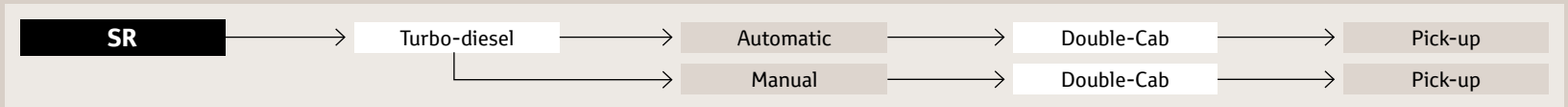



4x4 HiLux Model	Engine Type	Transmission	Cab	Style
-----------------	-------------	--------------	-----	-------

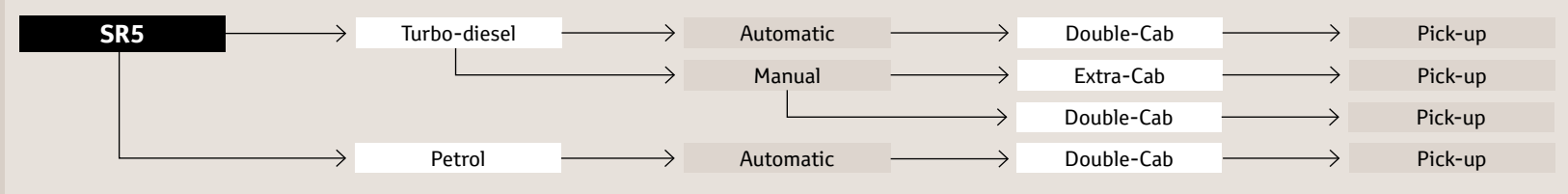
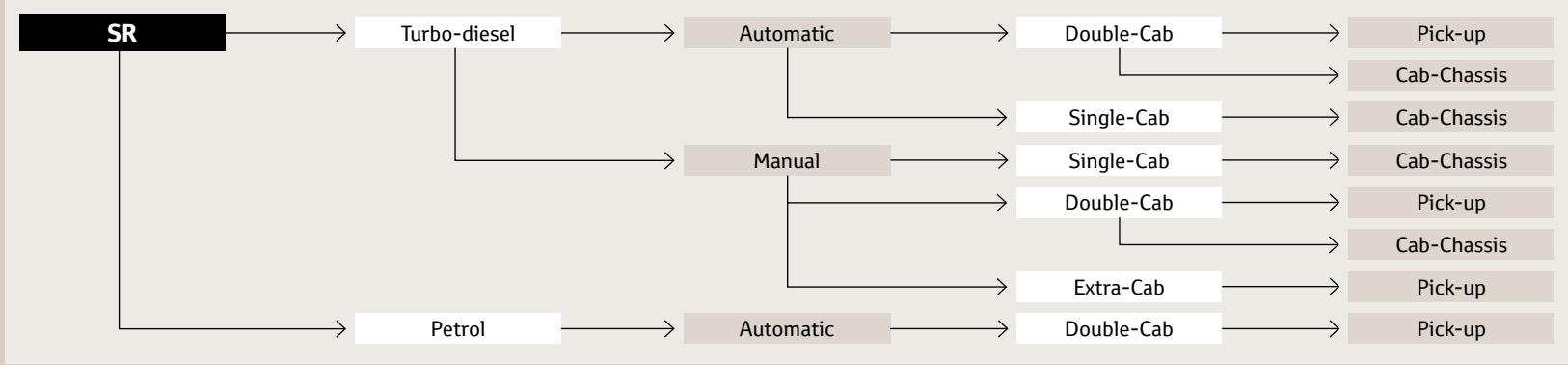
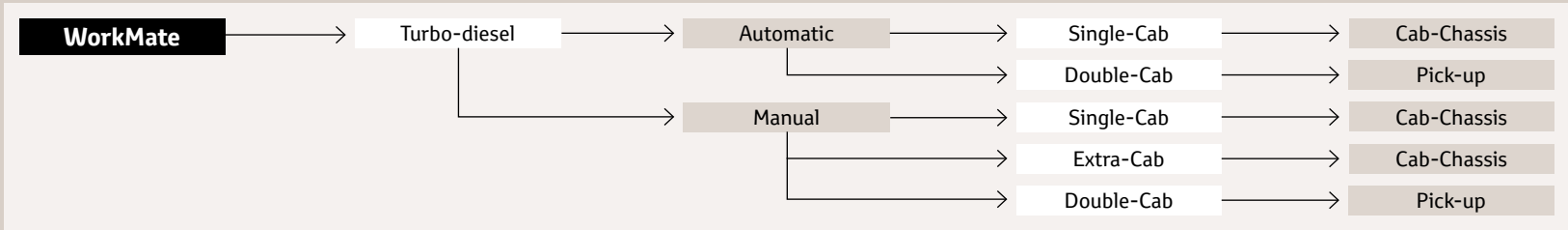

# HiLux WorkMate.



4x2 WorkMate Single-Cab Cab-Chassis shown in Glacier White shown with optional Toyota Genuine Tray Body

4x4 WorkMate Extra-Cab Cab-Chassis shown in Silver Sky<sup>1,2</sup> shown with optional Toyota Genuine Tray Body

The perfect companion to get the job done with plenty of refinements when it's time to put the tools down.

- 2.7L Petrol engine
- 2.4L Turbo-diesel engine
- Emergency stop signal
- Seatbelt warning – not applicable to Extra-Cab rear seats
- Heavy duty suspension and underbody package – Hi-Rider and 4x4 variants only
- 6-speed manual transmission – 4x4 and Hi-Rider only
- 6-speed automatic transmission
- 5-speed manual transmission – 4x2 only
- Remote keyless entry
- Front cupholders
- Power windows
- Auto on/off headlamps
- Manual tilt steering column
- Manual telescopic steering column – excludes 4x2 Single-Cabs
- Air conditioning
- 6.1" display audio
- Black electric side mirrors
- Halogen Daytime Running Lamps (DRLs)
- Side and rear defroster
- 12V accessory socket
- Reversing Camera – Pick-Up variants only
- Audio, telephone steering wheel switches
- 3.5mm AUX and USB input<sup>1</sup> for portable audio players
- Small centre console box
- Overhead console box
- Bluetooth<sup>®</sup> capability<sup>2</sup>
- Manual headlamp levelling
- 2 speakers



# HiLux SR.



4x2 SR Double-Cab Pick-up shown in Olympia Red<sup>12</sup>

4x4 SR Double-Cab Cab-Chassis shown in Graphite<sup>12</sup>  
shown with optional Toyota Genuine Tray Body

The HiLux that's ready to rise for any mission or occasion. In addition to or replacement of WorkMate features:

- 2.8L Turbo-diesel engine
- 4.0L VVT-i V6 Petrol engine
- 6-speed automatic transmission
- 6-speed manual transmission – 4x4 and Hi-Rider only
- 5-speed manual transmission – 4x2 only
- Front air conditioned cooler box
- Chrome exterior door handles
- Body coloured front bumper
- Differential lock – 4x4 only
- 60/40 Rear Seat (Tip up) – Double-Cab only
- Premium fabric seats
- Side steps – 4x4 and Hi-Rider only
- Floor carpet
- Multi Information Display (MID)
- Front personal lamp
- 7" display audio with Toyota Link<sup>10</sup>

# HiLux SR5.



4x4 SR5 Extra-Cab Pick-up shown in Nebula Blue<sup>12</sup>



4x4 SR5 Double-Cab Pick-up shown in Eclipse Black<sup>12</sup>

The head turning HiLux that packs a powerful punch. In addition to or replacement of SR features:

- 4.0L VVT-i V6 Petrol engine
- 2.8L Turbo-diesel engine
- Smart Entry and Start system
- 18" alloy wheels
- Downhill Assist Control<sup>8</sup> (DAC) – 4x4 Automatic models only
- 220V accessory socket – Double-Cab only
- intelligent Manual Transmission (i-MT)
- Integrated LED Daytime Running Lamps (DRLs)
- Front fog lamps
- Single-zone climate control
- Satellite Navigation<sup>3</sup>
- Chrome interior door handles
- Privacy glass
- Stainless steel sports bar
- LED Headlamps with auto-levelling
- Premium gear knob and steering wheel
- 4.2" colour Multi Information Display (MID)
- Alarm
- Leather Accented interior and power-adjustable driver's seat option pack (Double-Cab Turbo-diesel only)
- Towbar Receiver (Towball, Tongue and Wiring Harness sold separately)



# Great colours. Tough choice.

Now you can have Unbreakable in the colour<sup>11,12</sup> of your choice. The hardest part is picking which one you like best.

- A. Glacier White
- B. Crystal Pearl<sup>12,13</sup>
- C. Silver Sky<sup>12</sup>
- D. Graphite<sup>12</sup>
- E. Eclipse Black<sup>12</sup>
- F. Olympia Red<sup>12,14</sup>
- G. Nebula Blue<sup>12</sup>



# Smart thinking, all the way through.

It might be hard as nails outside, but HiLux is anything but within. Step inside and find yourself surrounded by the ergonomic appeal of well thought out interior space. Everything is where it should be, in easy reach and easy to use.

Each HiLux features power windows, seats covered in soft yet durable material that offer outstanding comfort and support, even after a long day on the road. Plus you'll find heaps of handy pockets and compartments to store all your essential stuff, such as sunglasses, work gear and clothes.

In SR and SR5 HiLux, an air-conditioned cooler box sits above the glove box and is perfect for keeping your lunch or refreshments chilled at an adjustable temperature. And the 220V accessory connector on Double-Cab SR5 models is ideal to charge your laptop or phone on the go.



WorkMate Single-Cab model shown



SR5 Double-Cab with optional Leather Accented interior shown (Turbo-diesel Automatic only)



SR5 Extra-Cab model shown

# Tough any way you want it.

Only Toyota Genuine Accessories<sup>15</sup> are designed to be the perfect fit for your HiLux, with some Accessories developed in conjunction with the vehicle up to 5 years before launch. They're built to take 'Unbreakable' to the next level and you can add what you need so there's no limit to what your HiLux can do. Accessorise your HiLux to suit your lifestyle with a huge range that ensures there's something for everyone.

To find out more, go to  
[www.toyota.com.au/hilux/accessories](http://www.toyota.com.au/hilux/accessories)

- A. Premium Steel Bull Bar**  
(Fog Lamp version shown)
- B. Commercial Steel Bull Bar**
- C. Side Rails**  
(Premium Steel Bull Bar and Side Steps sold separately)
- D. Side Steps**
- E. Tray Range** (Heavy Duty Alloy Tray shown)
- F. Rubber Cargo Mat**
- G. All Weather Rubber Floor Mats** (Front and Rear sold separately)

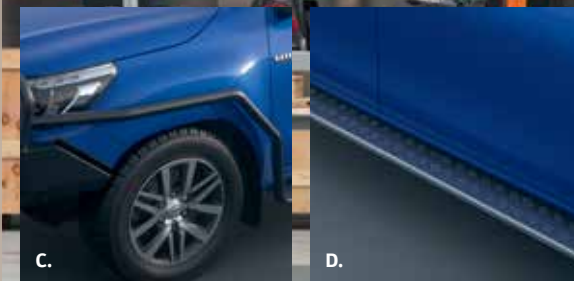





4x4 WorkMate Extra-Cab Cab-Chassis Turbo-diesel in Eclipse Black<sup>12</sup> shown accessorised with Commercial Steel Bull Bar, 18" Alloy Wheels, Heavy Duty Steel Tray Body, Colour Matched Ladder Rack, Side Steps, Bonnet Protector, Headlamp Covers and Weathershields. All accessories sold separately.



- A. Alloy Bull Bar**  
(Winch and Fog Lamp compatible version shown)
- B. Snorkel**
- C. Canopy**
- D. Nudge Bar**
- E. Hard Tonneau Cover**
- F. 18" Alloy Wheel**  
(Shown in Matte Black)



- G. Towbar or Towbar Tongue, Towball and Trailer Wiring Harness<sup>6,16</sup>**  
(Each sold separately)
- H. Soft Tonneau Cover**
- I. Ski/Snowboard Holder**
- J. Pro-Ride Bicycle Carrier**  
(Roof Racks sold separately)
- K. Roof Racks**







4x4 SR5 Double-Cab Pick-up Turbo-diesel in Nebula Blue<sup>12</sup> shown accessorised with Alloy Bull Bar, 18" Alloy Wheels, Driving Lights, Bonnet Protector, Headlamp Covers, Weathershields, Snorkel, Roof Racks and Hard Tonneau Cover. All accessories sold separately.







HILUX SPECIFICATIONS		4x2						Hi-Rider		
Body Type		Single-Cab			Extra-Cab	Double-Cab				
Grade		WorkMate		SR	SR	WorkMate		SR		SR5
Engine		Petrol	Turbo-diesel	Turbo-diesel	Turbo-diesel	Petrol	Turbo-diesel	Petrol	Turbo-diesel	Turbo-diesel
Tray Type		Cab-Chassis	Cab-Chassis	Cab-Chassis	Pick-Up	Pick-Up	Pick-Up	Pick-Up	Pick-Up	Pick-Up
Dimensions and Vehicle Weights <sup>17</sup>										
<b>Overall</b>	Length / Width / Height (mm)	- / - / 1690	- / - / 1690	- / - / 1690	5330 / 1800 / 1695	5330 / 1800 / 1700	5330 / 1800 / 1700	5330 / 1800 / 1700	5330 / 1855 / 1815	5330 / 1855 / 1815
	Wheelbase (mm)	3085	3085	3085	3085	3085	3085	3085	3085	3085
	Track – front / rear (mm)	1510 / 1510	1510 / 1510	1510 / 1510	1510 / 1510	1510 / 1510	1510 / 1510	1510 / 1510	1535 / 1550	1535 / 1550
	Overhang – front / rear (mm)	1000 / -	1000 / -	1000 / -	1000 / 1250	1000 / 1250	1000 / 1250	1000 / 1250	1000 / 1245	1000 / 1245
<b>Weight</b>	Kerb weight manual <sup>18</sup> (kg)	1475	1570	1575	1770	1745	1840		1930	1930
	Kerb weight automatic <sup>18</sup> (kg)	1490				1755		1795	1930	
	Gross Vehicle Mass <sup>19</sup> (GVM) (kg)	2700	2810	2810	2810	2780	2860	2810	2930	2930
	Gross Combined Mass <sup>20</sup>	5200	5280	5300	5310	5250	5360	5310	5650	5650
<b>Towing capacity<sup>6</sup></b>	With trailer brakes (kg) – manual / automatic	2500 / 2500	2500 / -	2500 / -	2500 / -	2500 / 2500	2500 / -	2500 / -	2800 / 2800	2800 / -
	Without trailer brakes (kg)	750	750	750	750	750	750	750	750	750
<b>Seating</b>	Capacity	2	2	2	4	5	5	5	5	5
<b>Fuel Tank</b>	Capacity (L)	80	80	80	80	80	80	80	80	80
<b>Steering System</b>	Steering Gear Type	Rack and Pinion								
<b>Brake System</b>	System	Vacuum boosted hydraulic system								
	Front / Rear	Ventilated disc brake with floating single piston caliper / Leading-trailing drum brake								
<b>Suspension</b>	Front / Rear	Double wishbone / Leaf spring rigid axle								
<b>Wheels and Tyres</b>	Wheels	16 x 6J	16 x 6J	16 x 6J	16 x 6J	16 x 6J	16 x 6J	16 x 6J	17 x 7.5J	18 x 7.5J
	Tyres	215/65R16C 106/104S	215/65R16C 106/104S	215/65R16C 106/104S	215/65R16C 106/104S	215/65R16C 106/104S	215/65R16C 106/104S	215/65R16C 106/104S	265/65R17 112S	265/60R18 110H



HILUX SPECIFICATIONS		4x4										
Body Type		Single-Cab		Extra-Cab			Double-Cab					
Grade		WorkMate	SR	WorkMate	SR	SR5	WorkMate	SR			SR5	
Engine		Turbo-diesel	Turbo-diesel	Turbo-diesel	Turbo-diesel	Turbo-diesel	Turbo-diesel	Petrol	Turbo-diesel	Turbo-diesel	Petrol	Turbo-diesel
Tray Type		Cab-Chassis	Cab-Chassis	Cab-Chassis	Pick-Up	Pick-Up	Pick-Up	Pick-Up	Pick-Up	Cab-Chassis	Pick-Up	Pick-Up
Dimensions and Vehicle Weights <sup>17</sup>												
Overall	Length / Width / Height (mm)	- / - / 1795	- / - / 1795	- / - / 1810	5330 / 1855 / 1810	5330 / 1855 / 1810	5330 / 1855 / 1815	5330 / 1855 / 1815	5330 / 1855 / 1815	- / - / 1815	5330 / 1855 / 1815	5330 / 1855 / 1815
	Wheelbase (mm)	3085	3085	3085	3085	3085	3085	3085	3085	3085	3085	3085
	Track – front / rear (mm)	1495 / 1510	1495 / 1510	1535 / 1550	1535 / 1550	1535 / 1550	1535 / 1550	1535 / 1550	1535 / 1550	1535 / 1550	1535 / 1550	1535 / 1550
	Overhang – front / rear (mm)	1000 / -	1000 / -	1000 / -	1000 / 1245	1000 / 1245	1000 / 1245	1000 / 1245	1000 / 1245	1000 / 1245	1000 / -	1000 / 1245
Weight	Kerb weight manual <sup>18</sup> (kg)	1775	1795	1880	2045	2040	2045		2080	1955		2075
	Kerb weight automatic <sup>18</sup> (kg)	1775	1795				2045	2000	2080	1955	2000	2075
	Gross Vehicle Mass <sup>19</sup> (GVM) (kg)	3000	3000	3000	3050	3050	3000	3000	3000	3000	3000	3000
	Gross Combined Mass <sup>20</sup>	5850 (MT) / 5650 (AT)	5850 (MT) / 5650 (AT)	5850	5850	5850	5850 (MT) / 5650 (AT)	5750	5850 (MT) / 5650 (AT)	5850 (MT) / 5650 (AT)	5750	5850 (MT) / 5650 (AT)
Towing capacity <sup>6</sup>	With trailer brakes (kg) – manual / automatic	3200 / 3000	3500 / 3200	3200 / -	3500 / -	3500 / -	3200 / 3000	3000 / -	3500 / 3200	3500 / 3200	3000 / -	3500 / 3200
	Without trailer brakes (kg)	750	750	750	750	750	750	750	750	750	750	750
Seating	Capacity	2	2	4	4	4	5	5	5	5	5	5
Fuel Tank	Capacity (L)	80	80	80	80	80	80	80	80	80	80	80
Steering System	Steering Gear Type	Rack and Pinion										
Brake System	System	Vacuum boosted hydraulic system										
	Front / Rear	Ventilated disc brake with floating single piston caliper / Leading-trailing drum brake										
Suspension	Front / Rear	Double wishbone / Leaf spring rigid axle										
Wheels and Tyres	Wheels	17 x 6J	17 x 6J	17 x 7.5J	17 x 7.5J	18 x 7.5J	17 x 7.5J	17 x 7.5J	17 x 7.5J	17 x 7.5J	18 x 7.5J	18 x 7.5J
	Tyres	225/70R17C 108/106S	225/70R17C 108/106S	265/65R17 112S	265/65R17 112S	265/60R18 110H	265/65R17 112S	265/65R17 112S	265/65R17 112S	265/65R17 112S	265/65R17 112S	265/60R18 110H

HILUX GRADE		WorkMate			SR			SR5	
Body Type		Single-Cab	Extra-Cab	Double-Cab	Single-Cab	Extra-Cab	Double-Cab	Extra-Cab	Double-Cab
Exterior	Body colour front bumper				*	*	*	*	*
	Chrome step type rear bumper							*	*
	Multi-reflector headlamps	*	*	*	*	*	*	*	*
	Front fog lamps							*	*
	Privacy glass							*	*
	Side steps (Hi-Rider and 4x4 variants only)				*	*	*	*	*
	Stainless steel sports bar							*	*
	Rear Access Door		*			*		*	
	LED headlamps with auto-levelling (Low beam only)							*	*
	LED Daytime Running Lamps (DRLs)							*	*
	Halogen DRLs	*	*	*	*	*	*		
Interior	Standard fabric seat	*	*	*					
	Premium fabric seat				*	*	*	*	*
	Premium Leather Accented seat (Turbo-diesel only)								OPT
	Premium gear knob and steering wheel							*	*
	Large colour Multi Information Display (MID)							*	*
	Chrome interior door handles							*	*
	Durable vinyl floor covering	*	*	*					
	Floor carpet				*	*	*	*	*
	Front air conditioned cooler box				*	*	*	*	*
Seating	Driver's bucket seat (Basic)	*	*	*					
	Driver's bucket seat (High grade)				*	*	*	*	*
	60/40 split rear seat						*		*
	Front passengers bucket seat (Basic)	*	*	*					
	Front passengers bucket seat (High grade)				*	*	*	*	*









# The Toyota Advantage.

Every Toyota gives you a lifetime of advantages. That's what makes it a Toyota. You'll enjoy legendary Toyota value from the moment you drive away, and you'll continue to appreciate the quality, safety and innovation that's engineered into each model, every day you drive.



## A smarter way to buy.

Toyota Access puts you in complete control when buying a new car.<sup>22</sup> Drive out of the Dealership with a clear road ahead then drive back a few years later with more options at your disposal than ever before. Whatever stage you're at in life, Toyota Access puts you in the driver's seat with ongoing flexibility and assurance. To discover Toyota Access for yourself visit [toyota.com.au/access](http://toyota.com.au/access)



## Finance to get you going.

If you need a little help, Toyota Finance<sup>25</sup> can offer you a wide range of vehicle financing. With Toyota Finance, you'll have the peace of mind of dealing with one of Australia's leading vehicle finance corporations with over 30 years experience. And with a range of flexible products and services to suit almost every need and circumstance, Toyota Finance can help find the right package for you or your business.



## Capped price servicing<sup>23</sup>

A new Toyota means you don't have to worry about unexpected service costs. Every Toyota comes with a low, capped price service cost for a set number of years/kilometres. Pay the same low capped price from one eligible logbook service to the next for up to three years or 60,000km, whichever occurs first (including Genuine parts, labour and fluids). For the full benefits consult a Toyota Dealer or visit [toyota.com.au/advantage](http://toyota.com.au/advantage)



## Even more protection.

Our Comprehensive Motor Vehicle insurance<sup>26</sup> policy is packed with great benefits including; agreed value cover or New vehicle replacement cover for Toyota vehicles damaged beyond repair within 3 years of original registration, Genuine Parts Promise and Lifetime Repair Guarantee. And our Toyota Insurance Factory Approved Extended Warranty Insurance provides protection that continues after your Toyota New Vehicle Warranty ends.



## We've got your back.

Every new Toyota is built to exceptional standards, backed by a three year/100,000km<sup>24</sup> warranty, giving you the peace of mind to feel confident for years to come. In the unlikely event that you need them, every Toyota Service Centre is committed to providing any warranty repairs you may need. They have the technology, the tools, and the skilled personnel to keep your Toyota in excellent condition.



## Extend your peace of mind.

Whether it's a flat tyre, lost keys or a flat battery, Toyota Extra Care Roadside Assist<sup>27</sup> is never more than a phone call away. Available 24 hours a day, seven days a week, every day of the year, you'll have peace of mind, whatever your emergency. With two levels of cover available, Toyota Extra Care Roadside Assist provides one of the most professional, reliable, and technologically advanced assistance networks in Australia.



# Disclaimers and Notice.

- 1 Not all devices will be compatible. Functionality varies depending on device.
- 2 The Bluetooth® word mark is owned by Bluetooth SIG, Inc. Not all devices will be compatible and functionality varies depending on the device.
- 3 Current navigation mapping database encompasses major capital and primary national road networks and offers some coverage in regional areas. Available on current SR5.
- 4 Hill-start Assist Control is a driver assist technology and should not be used as a substitute for safe driving practices.
- 5 Downhill Assist Control is a driver assist technology and should not be used as a substitute for safe driving practices. Areas into which the vehicle is driven must be visually monitored.
- 6 Towing capacity is subject to regulatory requirements, towbar and vehicle design and towing equipment limitations. Ask your Dealer for Toyota Genuine Towbar capacity and availability details.
- 7 Power and torque test standards differ. Ensure comparisons use same test standard.
- 8 Results achieved in test conditions. Actual results may vary depending on driving conditions/style, vehicle condition and options/accessories fitted. Fuel consumption data provided for comparison purposes only. Source: ADR81/02 combined.
- 9 Reversing Camera is a driver assist device only and should not be used as a substitute for safe driving practices. The area into which the vehicle is driven must be visually monitored by the driver.
- 10 Toyota Link is available on certain vehicle models and grades only. Toyota Link services rely on data from the driver's compatible mobile phone and information provided by third parties. Availability is dependent on a number of factors, including the availability of third party information, mobile service, sufficient mobile data allowance and GPS satellite signal reception. Mobile usage is at the user's cost. Toyota Australia reserves the right to add, remove or modify applications. Further information is provided at [www.toyota.com.au/toyotalink](http://www.toyota.com.au/toyotalink)
- 11 Toyota Australia reserves the right to vary and discontinue the current interior and exterior colours, trims and colour/trim/model combinations. Colours and trims displayed here are a guide only and may vary from actual colours due to printing / display process. See your Toyota dealer to confirm colour/trim/model availability when ordering your vehicle. Metallic / mica pearlescent paint is optional and subject to additional charges on most models.
- 12 Paint featured is an optional extra at additional cost.
- 13 Only available on SR5 Double-Cab.
- 14 Not available on Single-Cab.
- 15 Toyota Genuine Accessories are not applicable to all models/grades. Consider the mass of your load to ensure you will not exceed the maximum allowable individual axle capacity, Gross Vehicle Mass and/or Gross Combined Mass of the vehicle. Refer to the current Accessories brochure or visit [toyota.com.au](http://toyota.com.au) for details on warranty and [toyota.com.au/vehiclepayload](http://toyota.com.au/vehiclepayload) for details on vehicle payload, to help determine Accessories suitable for your vehicle. Accessory colours shown may vary from actual colour due to the printing process.
- 16 HiLux SR5 models come fitted with a Towbar Receiver as standard.
- 17 Some vehicle dimension figures are approximate and vary due to options and accessory fitment.
- 18 Stated kerb, tare and payload weights are nominal and vary depending on options and accessories. For example, any fitted Towbar weight has not been included.
- 19 Gross Vehicle Mass (GVM) is the total permissible combined weight of the vehicle, including occupants, fuel and cargo.
- 20 Gross Combined Mass (GCM) is the total permissible combined weight of the vehicle and trailer/caravan being towed including occupants, fuel & cargo
- 21 iPod® is a trademark of Apple, Inc. Not all devices will be compatible and functionality will vary depending on the device.
- 22 Terms and Conditions, fees and charges apply. Toyota Access Guaranteed Future Value products are available to approved customers of Toyota Finance, a division of Toyota Finance Australia Limited ABN 48 002 435 181, AFSL and Australian Credit Licence 392536.
- 23 Maximum payable for standard scheduled logbook servicing (normal operating conditions) until first of three years or 60,000km (whichever occurs first), up to the first six services. Excludes Government & Rental vehicles. Contact your Toyota Dealer or go to [toyota.com.au/advantage](http://toyota.com.au/advantage) for other exclusions, eligibility and full details.
- 24 New Vehicle Warranty expires three years from date of first delivery or 100,000km, whichever occurs first. Refer to the warranty conditions. The New Vehicle warranty does not limit and may not necessarily exceed your rights under the Competition and Consumer Act 2010.
- 25 Toyota Finance is a division of Toyota Finance Australia Limited ABN 48 002 435 181, AFSL and Australian Credit Licence 392536.
- 26 Terms and conditions apply. This advice is general in nature and does not take into account your objectives, financial situation or needs. Before making a decision to purchase any of the insurance products you should consider the appropriateness of the advice taking into account your own objectives, financial situation and needs and refer to the current PDS for the relevant product available from participating Dealers, via our website at [toyotainsurance.com.au](http://toyotainsurance.com.au) or by calling 137 200. Toyota Insurance is issued by Toyota Finance Australia, Limited ABN 48 002 435 181, AFSL and Australian Credit Licence 392536. The insurer is Aioi Nissay Dowa Insurance Company Australia Pty Ltd ABN 11 132524 282, AFSL 443540. Our insurance policies do not change or take away your rights under the Australian Consumer Law. Your right to claim under our policies for the benefits covered are in addition to other rights and remedies you have under the law in relation to your vehicle. However, you can choose to make a claim under any of our policies even if you have rights under the law.
- 27 Toyota Extra Care is administered by Toyota Finance, a division of Toyota Finance Australia Limited ABN 48 002 435 181, AFSL and Australian Credit Licence 392536.

## IMPORTANT NOTICE – PLEASE READ:

Toyota Australia uses its best endeavours to ensure this material is correct when published. You must check with your authorised Toyota Dealer when ordering to ensure the vehicle with your chosen specifications, equipment and colour is available and that the vehicle can be delivered within the timeframe suitable to you. When ordering accessories, you must check with your authorised Toyota Dealer to ensure the accessory's design, features and colours are available and will fit your vehicle. Please also consider the mass of your load to ensure you will not exceed the maximum allowable individual axle capacity, Gross Vehicle Mass and/or Gross Combined Mass of the vehicle. Refer to [toyota.com.au/payload](http://toyota.com.au/payload) for further details. Colours displayed here are a guide only and may vary from actual colours due to printing/display processes. Certain accessories when fitted will require the removal of standard equipment.

Standard equipment may be retained by Toyota Australia. Toyota Australia reserves the right to change, without notice, at any time prices, colours, materials, equipment, specifications and discontinue colours/models. To the extent permitted by law, Toyota Australia will not be liable for any damage, loss or expense incurred as a result of reliance on this material in any way. Distributed nationally (other than in Western Australia) by Toyota Motor Corporation Australia Limited ABN 64 009 686 097, 155 Bertie St, Port Melbourne 3207. Material distributed in Western Australia by or on behalf of Prestige Motors Pty Ltd (for vehicles) and by Eastpoint Pty Ltd (for parts/accessories). Toyota Australia makes no warranties regarding (and will not be liable for) the accuracy of materials distributed in Western Australia. PART NUMBER: TYHILUXPACKBRO. PROOF HQ: T2016-005151. PRINTED: JANUARY 2017. GTO1780.



SR5 Hi-Rider Double-Cab Pick-up Turbo-diesel in Olympia Red<sup>1,2</sup> shown accessorised with Roof Racks. All accessories sold separately.