

The B-Class



Overseas model shown. Certain options and features may not be available locally.

Mercedes-Benz



This brochure is prepared by Mercedes-Benz Group AG or one of its Group Companies and it predominantly reflects the capabilities and performance of vehicles sold in Europe. Some characteristics, capabilities, performance features and optional extras (e.g. towing systems) may not be available or may not apply in Australia or under Australian conditions. The information in this Brochure is therefore indicative, illustrative and provided only for guidance and should not be relied on. To obtain current and accurate information on a vehicle and any options applicable to Australia, contact your local authorised Mercedes-Benz retailer. The declared fuel and energy consumption figures are determined by testing under standardised laboratory conditions to comply with ADR 81/02. Real world fuel consumption is influenced by many additional factors such as fuel quality, individual driving style, load, traffic, and vehicle condition. The declared fuel consumption figure should only be used for the purpose of comparison amongst vehicles.

Justify nothing.

If everything feels perfect, you really have no need to offer justification for anything. Not for your lifestyle. Not for your sense of style. And least of all for a car that offers exemplary safety and comfort. The most intuitive operating concept in its class, and styling that is more dynamic than ever before. Discover the new B-Class from Mercedes-Benz.



Overseas model shown. Certain options and features may not be available locally.



As you like it.

Emphatically sporty, particularly elegant or dynamically modern: you set the tone for the exterior of the new B-Class. Choose between the AMG and Style Lines. And combine these as you wish with optional equipment and packages. To make the B-Class your very own B-Class. Exactly to your taste.

Overseas model shown. Certain options and features may not be available locally.



This same sort of variability is also to be found in relation to the ride feeling.

A tap on the DYNAMIC SELECT switch is all it takes for a sporty set-up. The new B-Class offers a thrilling driving experience tailored perfectly to you and your driving situation.

Overseas model shown. Certain options and features may not be available locally.



Family cars are not what they used to be.

Elegant trim elements, sensuously pure lines and a dynamic “wrap-around” design embrace you as soon as you get into the car. The state-of-the-art steering wheel with Touch Control buttons and the Widescreen Cockpit with intuitive voice-operated control are there to take the pressure off you when driving. At a touch, or with just two little words: “Hey Mercedes”.



Climb aboard.

Whether with its raised seating position, its excellent all-round visibility or its extra-low load compartment sill: the new B-Class simply gives you more freedom. A variable load compartment floor, along with rear seats that split in up to three ways, also enhance the car's flexibility and space.



Your Personal Assistant is already to hand.

Apart from its fully intuitive operation, the new B-Class also gets better every day at adapting to your needs and habits. It notes your route to the office, for example, and can automatically offer a faster route in case of a traffic jam.

Overseas model shown. Certain options and features may not be available locally.



Because safety is
sometimes everything.

The new B-Class is fitted with a series of assistance systems that are now able to react even more intelligently, precisely and quickly. At speeds of up to 200 km/h these will automatically hold you at a set distance, change lane, start up again in queuing traffic or even brake if need be. This means you and your passengers are always in the best of hands.

Overseas model shown. Certain options and features may not be available locally.



Exemplary safety.

In rush hour, during a long drive at night or on an unfamiliar route, your new B-Class noticeably takes the strain out of driving, particularly in stressful situations. It's all down to a concept that makes every journey in a Mercedes-Benz a safer and exceptional experience: Mercedes-Benz Intelligent Drive. Because the time you spend behind the wheel is your time. Time for relaxation. Time to replenish your energy. So that, first and foremost, you reach your destination safely, but are also relaxed when you get there.

EQUIPMENT HIGHLIGHTS – DRIVING ASSISTANCE SYSTEMS

The Driving Assistance package is a combination of sophisticated safety and assistance systems that can detect danger and issue an alert, or even brake, in an emergency.

PRE-SAFE® system. The innovative PRE-SAFE® Sound system generates a noise from the loudspeakers that can trigger a protective reflex: your auditory system briefly disconnects, thereby protecting itself from the loud noise of a crash.

Traffic Sign Assist: the camera and navigation data have the applicable speed in their sights at all times – so you are always aware of the current speed limit, even amid a forest of signs.

Park with an easy mind. The duo of Active Parking Assist and 360° camera supports you in looking for a parking space, as well as when entering and leaving a parking space or manoeuvring. The all-round view, thanks to the 360° camera including a virtual bird's-eye view, is particularly impressive.

Various safety systems and features included in Mercedes-Benz vehicles are driver assistance aids only and the driver at all times remains solely responsible for maintaining proper control of the vehicle, ensuring safety and monitoring the driving environment and complying with all applicable road rules.

Traffic Sign Assist is a driver assistance aid only and may not be accurate in all instances. The driver at all times remains solely responsible for monitoring the driving environment and observing all traffic and/or speed signs as well as complying with all applicable road rules.



MBUX (Mercedes-Benz User Experience).

Apart from its fully intuitive operation, the new B-Class also gets better every day at adapting to your needs and habits. It notes your route to the office, for example, and can automatically offer a faster route in case of a traffic jam. This all forms part of the revolutionary MBUX (Mercedes-Benz User Experience). A multimedia system that keeps learning about you and your preferences. Until the new B-Class knows you almost better than you know yourself.



EQUIPMENT HIGHLIGHTS – CONTROL AND DISPLAY CONVENIENCE

Widescreen Cockpit with LINGUATRONIC voice control system: thanks to the new MBUX voice control system, the new B-Class listens to you and understands you, without having to learn any commands beforehand. Two words from you are all it takes: "Hey Mercedes". and the new B-Class is all ears and ready for anything.

Touch Control concept: you won't find any conventional buttons and controls in the B-Class cockpit. Everything is new here. The touchscreen or the touchpad, for example, which allow you to operate and adjust almost anything in the car using a single finger.

Overseas model shown. Certain options and features may not be available locally.



Comfort suspension.

Enjoy a high level of comfort on long motorway stretches while tackling tight curves with sporty flair. The balanced comfort suspension provides an impressive mix of responsive suspension reserves with excellent driving stability. This makes your driving safe while at the same time providing a great deal of driving pleasure.

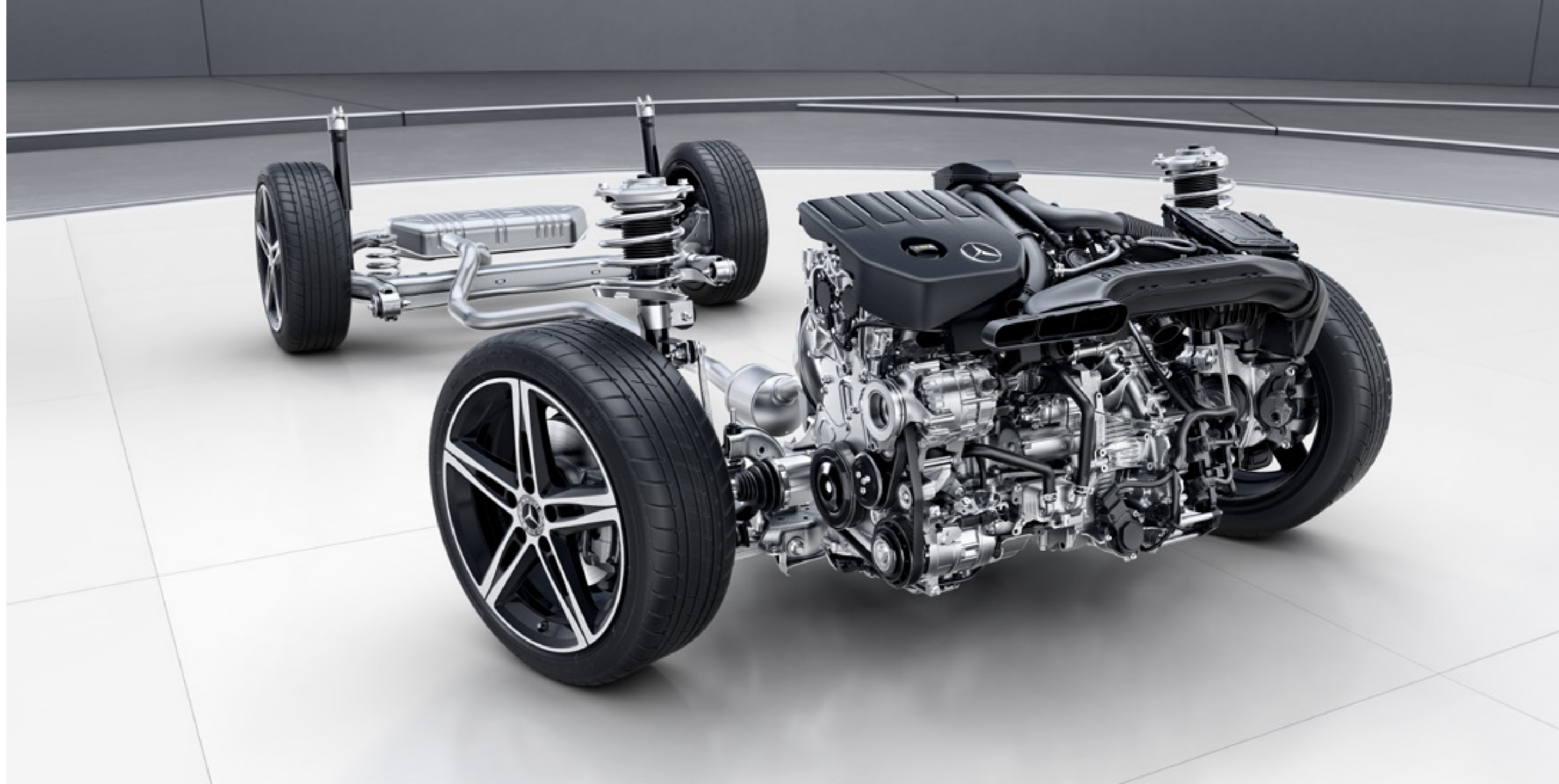

Technical data.

Petrol engines	
B 180	
Displacement (cc)	1332
Rated output ¹ (kW [hp] at rpm)	100 [136] / 5500
Acceleration from 0 to 100 km/h (s)	9.0
Top speed (km/h)	210
Fuel consumption ⁴ (l/100 km)	
Urban	Urban: 7.2
Extra-urban	Extra urban: 4.8
Combined	Combined 5.7
Combined CO ₂ emissions ⁴ (g/km)	Combined: 131

The best for the engine:
Mercedes-Benz genuine engine oils.

The declared fuel and energy consumption figures are determined by testing under standardised laboratory conditions to comply with ADR 81/02. Real world fuel consumption is influenced by many additional factors such as fuel quality, individual driving style, load, traffic, and vehicle condition. The declared fuel consumption figure should only be used for the purpose of comparison amongst vehicles. For more technical data, please visit www.mercedes-benz.com.au

Dimensions.

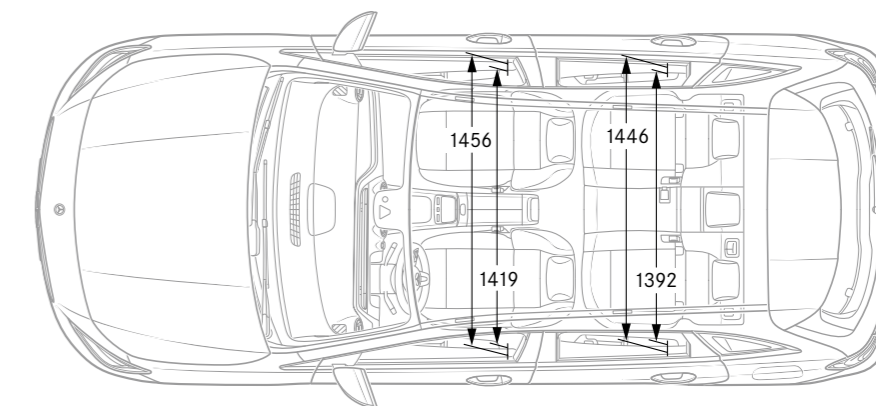
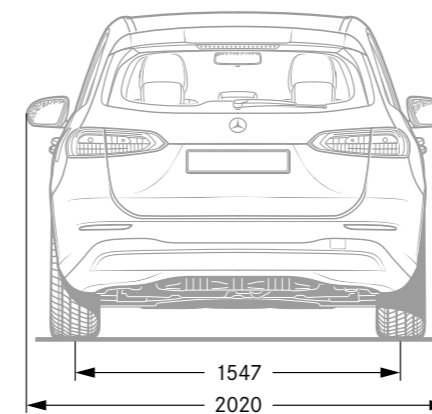
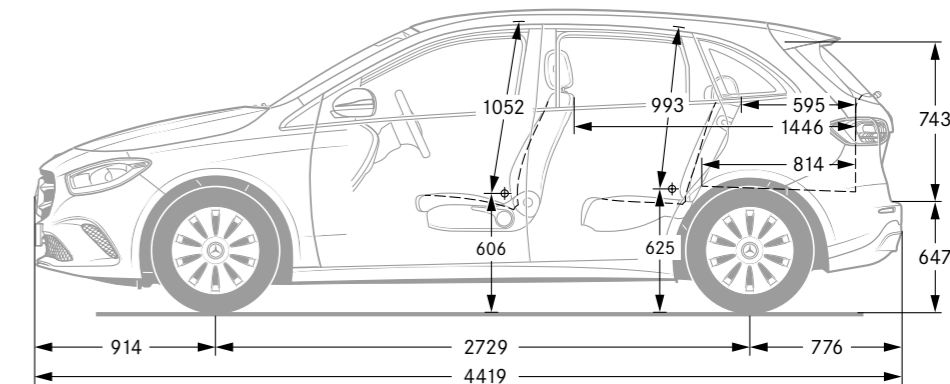
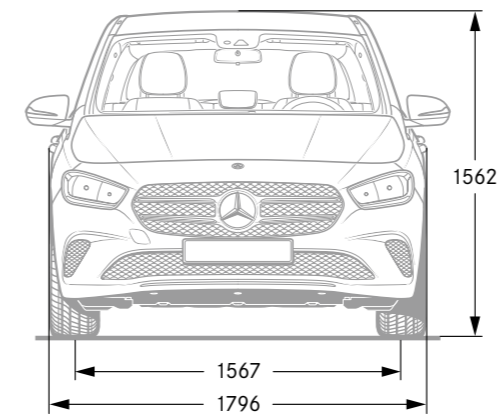

All figures in millimetres. The illustrated dimensions are mean values. They are valid for vehicles in basic specification and in unladen condition.



SPORT — F O R — GOOD

Mercedes-Benz is one of the founding partners of the worldwide “Laureus Sport for Good Foundation”, which was established in 2000. It is the Mercedes-Benz brand’s most important social initiative. Laureus Sport for Good supports children and young people in need through social sports projects, opening up new perspectives and imparting important values such as team spirit, respect and determination. “Change the Game for Kids” is our mission statement which we wish to share with you. In buying a Mercedes-Benz you are supporting the “Laureus Sport for Good” movement.

About the information in this publication: Changes may have been made to the product since the editorial deadline on 22.01.2019. The manufacturer reserves the right to make changes to the design, form, colour and the delivery scope during the delivery period, provided these changes, while taking into account the interests of the seller, can be deemed reasonable for the buyer. Where the seller or the manufacturer uses symbols or numbers to describe an order or the subject of an order, no rights may be derived solely from these.

The illustrations may also show accessories and optional equipment, which are not part of the standard delivery scope. Therefore, please ask your Mercedes-Benz sales representative about the provisions and effects applicable in other countries and about the latest definitive version.
www.mercedes-benz.com.au