

The C-Class Cabriolet



Mercedes-Benz







Never stop improving.

Only the best of their type have this drive: to become better, day by day. It's plain to see when you look at the new C-Class. The state-of-the-art MULTIBEAM LED headlamps and the powerful, sporty design of the AMG Line are set on one thing only: going further and further.

For those who know no limits.

With the new C-Class Cabriolet, the convertible season lasts all year round. Courtesy of its exceptional open-air comfort, with AIRCAP draught stop standard on all models.

AIRSCARF neck-level heating system and sun-reflecting leather are also features of the C 300 and Mercedes-AMG models. And if it should actually come on to rain, you can simply continue to admire the beauty of nature in the interior, with the new trim finishes of anthracite open-pore oak wood and brown open-pore walnut wood.





Innovative power from deep within.





Many of the control and display elements are completely new: the new steering wheel with Touch Control buttons and the fully digital instruments and larger displays, including a new infotainment generation, are state-of-the-art features that make operating the car a highly individual affair. The instruments can also feature the “Classic”, “Sporty” or “Progressive” display styles.



Ahead of its own best time.

A new electrified petrol engine with EQ Boost stands poised in the starting blocks. Complementing it perfectly is the new DYNAMIC BODY CONTROL suspension. For a sportily taut set-up and exceptional comfort, all it takes is the touch of a button.



D SICA 2052





64 colours. One unique ambience.

For any mood and any time of day or night. For any occasion and different each time: the ambient lighting transforms the interior of the new C-Class Cabriolet into a stunning lounge area. It comes with a range of 64 colours, which can be individually selected.



Mercedes-Benz Intelligent Drive.

Be it during the rush hour, on long night-time journeys or on unfamiliar routes. Your new Mercedes-Benz C-Class Cabriolet provides tangible relief in stressful situations. It's all down to a concept that makes every journey in a Mercedes-Benz such a safe and exceptional experience: Mercedes-Benz Intelligent Drive.

Because the time you spend behind the wheel is your time. Time for relaxation. Time to replenish your energy. So that, first and foremost, you reach your destination safely, but are also always relaxed when you get there.



ENERGISING COMFORT AND EXEMPLARY SAFETY

Driving Assistance Plus package: a new generation of stereo cameras and radar sensors enables a high level of driving assistance. Helpful for maintaining speed or distance as well as for automated braking or keeping in lane.

Particularly innovative: **PRE-SAFE® Sound** can generate a noise from the loudspeakers that triggers a protective reflex. The auditory system briefly disconnects, thus protecting itself from the loud noises of the crash.

The **360-degree camera** shows the surroundings of the vehicle in full on the multimedia system display.

Various safety systems and features included in Mercedes-Benz vehicles are driver assistance aids only and the driver at all times remains solely responsible for maintaining proper control of the vehicle ensuring safety and monitoring the driving environment and complying with all applicable road rules.



Digital cockpit.

Smartphone Integration connects the mobile phone with the media system via Apple CarPlay™ or Android Auto™, so providing convenient access to the most important applications of your smartphone. It also allows quick and easy use of apps from third-party service providers such as Spotify®.



YOUR GATEWAY TO THE DIGITAL WORLD OF MERCEDES-BENZ

The **fully digital instrument display** with the display styles “Classic”, “Progressive” and “Sporty” enables you to decide which information is important to you and how you wish to see it displayed. The 31.2 cm (12.3-inch) display delivers a pin-sharp image which is very easy to read in all light conditions.

The **high-resolution media display** in a 16:9 format with 10.25-inch screen diagonal adds a particularly high-quality touch to the interior of your vehicle. Thanks to the higher resolution of 1920 x 720 pixels you can enjoy brilliant image quality with a crisp illustration of all infotainment content.

Wireless charging system for mobile devices: driving time becomes charging time. With just a simple hand movement your smartphone can be fixed in place in the centre console where it is charged wirelessly. Irrespective of the model and brand, all smartphones supporting the Qi standard are charged wirelessly.

Wireless charging feature only compatible with devices that support the Qi standard. Check the compatibility of your device and vehicle in Australia at www.mercedes-benz-mobile.com for your device manufacturer.



Acoustic soft top.

Thanks to a fully automatic fabric acoustic soft top you will feel just as safe and secure in your Cabriolet as you would under a hardtop. The special acoustic fleece very effectively blocks out road noise and outside sounds, so minimising the ambient noise in the interior. It all adds up to a peaceful journey – even at high speeds.

Burmester® surround sound system.

Surround sound and superb tone in all seats: the Burmester® surround sound system offers music lovers an amazing listening experience. The overall sound pattern can be individually set to suit your own personal preference and the type of music being played – allowing you to enjoy exceptional quality at almost concert-hall level.



Cabriolet Comfort package.

Make the convertible season last all year round: enjoy optimum open-air comfort at any time and experience the changing seasons. With AIRSCARF neck-level heating, the AIRCAP draught stop system and the semi-automatic boot separator, the package bundles together intelligent equipment items that complement each other perfectly and totally pamper you.

Draught stop.

Protect yourself and your passengers from draughts – with the draught stop you can still drive with the roof open, even at higher speeds and when the temperature outside is cool. The mesh screen above the rear seats can be fitted in an instant and removed again at any time.

Standard equipment and appointments.

Thrilling design for genuine emotions: the exterior of the car in its standard guise is already stunning, featuring as it does powerful styling elements such as the diamond radiator grille with single louvre or the cutting-edge LED High Performance headlamps. The lowered suspension offers the perfect balance between dynamism, comfort and safety. The design idiom and materials selected to create the high-quality interior already exude a sporty lifestyle as standard. The integral-look seats are a particular highlight: they offer a low, comfortable seating position and perfect lateral support – and thus pure driving enjoyment.



The AMG Line.

The expressive styling of the AMG Line lends the exterior of the C-Class a sporty, exclusive touch. With it, you make a clear statement for powerful design. On top of this, the technical features give palpably more fun at the wheel, since the agile configuration of the sports suspension with Sports Direct-Steer makes the handling noticeably dynamic. The AMG Line interior adds to the vehicle's sportiness, both visibly and tangibly. With it, you make a clear statement and show immediately what matters to you: an ambience that is dynamic and exclusive in every detail.

The Night package.

Added character – expressive style. The Night package in conjunction with the AMG Line adds distinctive highlights through the use of exclusive black design elements. These emphasise the sporty character and the muscular design idiom of your vehicle. Ideal for individualists with a true appreciation of expressive design.



The designo interior.

Choose a touch of extravagant luxury: the two-tone designo interior adds expressive and individual flair to your car's interior. Bengal red trim is offset by black elements to create exciting contrast. The high-quality materials have been worked with superb craftsmanship.





DYNAMIC BODY CONTROL.

One suspension – three possible set-ups: with DYNAMIC BODY CONTROL, you can choose between maximum agility and high damping comfort. To match the route and your personal driving style. The low suspension level and the Sports Direct-Steer system provide you with the ideal conditions for a particularly dynamic driving style. The DYNAMIC BODY CONTROL suspension is equipped with continuously adjustable damping for both the front and rear axle. The stepless system interacts with the engine, transmission and steering characteristics to control the damping individually for each wheel – matched to the driving situation, vehicle speed and road surface. This variable configuration allows you to benefit from superb travelling comfort and outstanding driving dynamics.

FURTHER HIGHLIGHTS

It's possible to switch between a sporty and a comfortable configuration at the simple touch of a button, courtesy of the **DYNAMIC SELECT** switch in conjunction with one or other of the two available suspensions, DYNAMIC BODY CONTROL and AIR BODY CONTROL.



4MATIC all-wheel drive on C 43.

In city traffic, on country roads or on the motorway: with the permanent all-wheel drive system from Mercedes-Benz you will always feel safe on the road. The system improves traction when pulling away and accelerating, especially on a poor road surface. This is made possible by the perfect interplay between the 4MATIC system* and the electronic braking,

control and traction systems ABS, ESP® and 4ETS. The all-wheel drive system is constantly active and does not require any reaction time before intervening. Particularly on wet, snowy or icy roads, the improvement in driving and tracking stability is quite noticeable.

* Available in the C43 only.

No compromises.

Every Mercedes-AMG is a masterpiece in its own right, with an unmistakable character. What unites our performance vehicles and sports cars is their irrepressible sporting spirit. Their passion for top performance. It is generated at the point where engineering skill meets a very special attitude: the spirit of AMG. We believe that you have to keep on challenging limits in order to achieve new goals. We accept nothing as a given. Because limits are imposed by people, and it is also people who can overcome them. It's this attitude that enables us to achieve outstanding performance for the race track – and for the road.

Welcome to the world of AMG.

www.mercedes-amg.com



AMG
DRIVING PERFORMANCE



Technical data.

Displacement (cc)
Rated output ¹ (kW [hp] at rpm)
Acceleration 0-100 km/h (sec.)
Top speed (km/h)
Fuel consumption ⁴ (l/100 km)
Urban
Extra-urban
Combined
Combined CO ₂ emissions ⁴ (g/km)

Petrol engines

C 200	C 300	C 43	C 63 S
1497	1991	2996	3982
135 [184]	190 [258]	287 [390]	375 [510]
8.5	5.9	4.8	4.1
235 km/h	250 km/h	250 km/h	250 km/h
8.8	TBA	13.6	14.4
5.7	TBA	7.9	8.5
6.8	TBA	10.0	10.7
155	TBA	227	242

The best for the engine:
Mercedes-Benz genuine engine oils.

The declared fuel and energy consumption figures are determined by testing under standard laboratory conditions to comply with ADR 81/02. Real world fuel consumption is influenced by many additional factors such as fuel quality, individual driving style, load, traffic, and vehicle condition. The declared fuel consumption figure should only be used for the purpose of comparison amongst vehicles. For more technical data, please visit www.mercedes-benz.com.au

Dimensions.

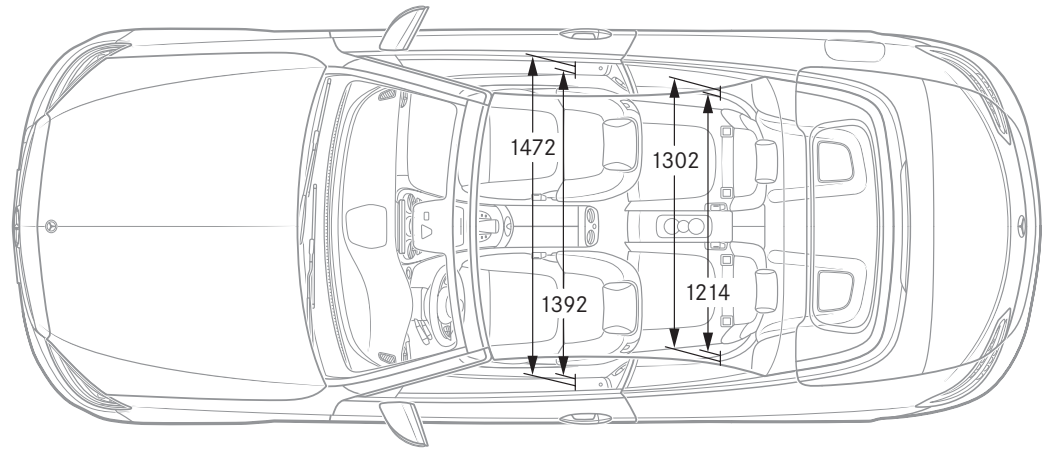
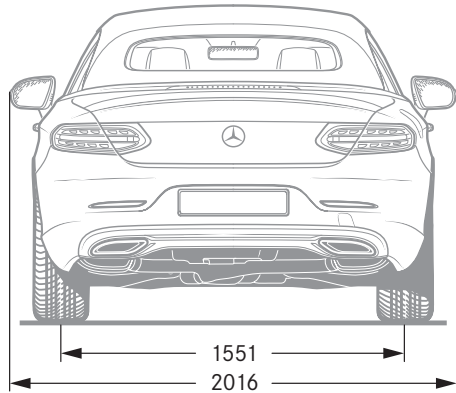
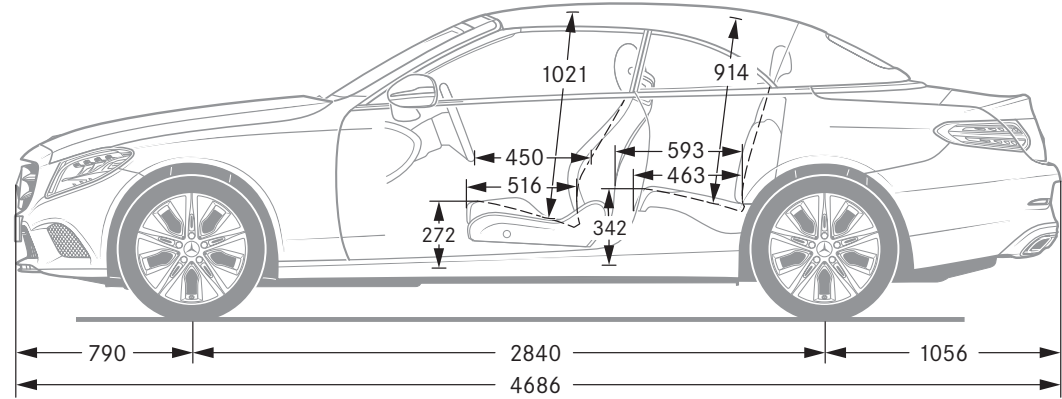
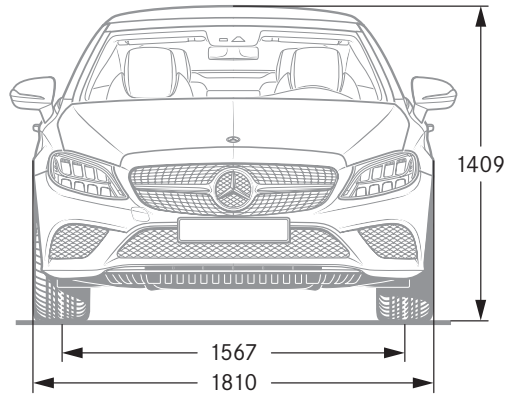

All figures in millimetres. The illustrated dimensions are mean values. They are valid for vehicles in basic specification and in unladen condition.



SPORT
— F O R —
GOOD

Mercedes-Benz is one of the founding partners of the “Laureus Sport for Good Foundation”.

Since the foundation was established in 2000, Mercedes-Benz has been supporting and promoting the aims and values of this worldwide non-profit-making programme: to use social sports projects to improve the lives of children and young people who are disadvantaged or suffering from illness. Laureus has become a fundamental element of Mercedes-Benz’s social responsibility. Every new Mercedes is an ambassador embodying these values. In buying a Mercedes you are supporting the “Laureus Sport for Good Foundation”.

Please note: changes may have been made to the product since the editorial deadline (16.07.2018). The manufacturer reserves the right to make changes to the design, form, colour and the product specification during the delivery period, provided these changes, while taking into account the interests of the vendor, can be deemed reasonable with respect to the purchaser. The illustrations may show accessories and items of optional equipment which are not part of

standard specification. This publication is distributed internationally. For the latest information regarding the regulations and implications in other countries, please contact your nearest authorised Mercedes-Benz dealer. www.mercedes-benz.com.au