

# The E-Class Coupé



Mercedes-Benz





This Brochure is prepared by Mercedes-Benz Group AG and it predominantly reflects the capabilities and performance of vehicles sold in Europe. Some characteristics, capabilities, performance features and optional extras (e.g. towing systems) may not be available or may not apply in Australia or under Australian conditions. The information in this Brochure is therefore indicative, illustrative and provided only for guidance and should not be relied on. To obtain current and accurate information on a vehicle and any options applicable to Australia, contact your local authorised Mercedes-Benz dealer.



## Made to win the day.

The new E-Class Coupé is the synthesis of luxurious comfort and dynamic sportiness.





## Dynamism from any angle.

The coupé design blends powerful contours and timeless modernity in a way that is particularly apparent in the sporty AMG Line. The new E-Class Coupé radiates dynamism from every angle.



## Climb in and win.

Start with the right feeling. The sporty-looking interior with the restyled steering wheel and the digital cockpit is characterised by high quality and flowing forms and represents a new interpretation of modern luxury.







## Chief Dynamicist.

Powerful engines and adjustable suspension\* make the new E-Class Coupé more agile than ever before. You determine how sportily you want to drive.

\*DYNAMIC BODY CONTROL suspension with adjustable damping optionally available for E 200.





## The perfect setting for success.

Reach your destination in comfort: the ENERGIZING packages\* offer many routes to relaxation – for example through music and sound, ambient lighting or seat massages. All functions are bundled as packages and can be called up individually and to suit your mood. Every programme helps enhance wellbeing and reduces stress.

\*The Energizing Package includes Climatized Front Seats including seat heating and ventilation, with perforations in leather. Energizing Package not available on E 200, optional on other models.





## MBUX.

Chief Digital Officer. The new E-Class Coupé boasts the latest infotainment system in the new digital cockpit, with a host of innovative features such as voice control and optional augmented reality.

\*Macchiato Beige / Yacht Blue Leather only available in conjunction with High-gloss light brown sen wood trim.



## MBUX Augmented Reality Navigation.

To enable you to find your way in complex traffic situations, MBUX Augmented Reality Navigation connects the virtual world with the real world. The technology incorporates graphical navigation instructions and traffic information into live images. So you reach your destination quickly, safely and stress-free.

All Multimedia, Connectivity and Software solutions (Applications and Data Content) contained within or associated with the vehicle are subject to terms and conditions. In some cases, the Applications and Data Content may be provided by third parties, not Mercedes-Benz Australia/Pacific Pty Ltd. Please refer to the relevant terms and conditions for more information including device compatibility, connectivity and capability requirements.





## New MULTIBEAM LED headlamps.\*

The MULTIBEAM LED headlamps automatically adapt to the surroundings and react to the traffic situation with individually controlled LEDs.

\*Not available for E200, standard for all other models

## Multi-spoke light-alloy wheels.

Poised assurance on the road. The modern rim designs give the new E-Class Coupé a scaled-back, contemporary style.

## Burmester® surround sound system.\*\*

Enjoy the high-performance speakers from Burmester®. Sophisticated noise compensation (VNC) dynamically adapts music and sounds to the driving situation in order to offer you the best possible musical enjoyment at all times.

\*\*Standard for Mercedes-AMG E 53 4MATIC+, optional for other models

## Ambient lighting.\*\*\*

Showcase the interior according to your personal preferences or current mood. The 64 colours of the ambient lighting system create exciting colour schemes, which can alternate dynamically or illuminate several areas in different colours.

\*\*\*Carbon Trim not available





A range of efficient and powerful 4 and 6-cylinder engines to choose from.

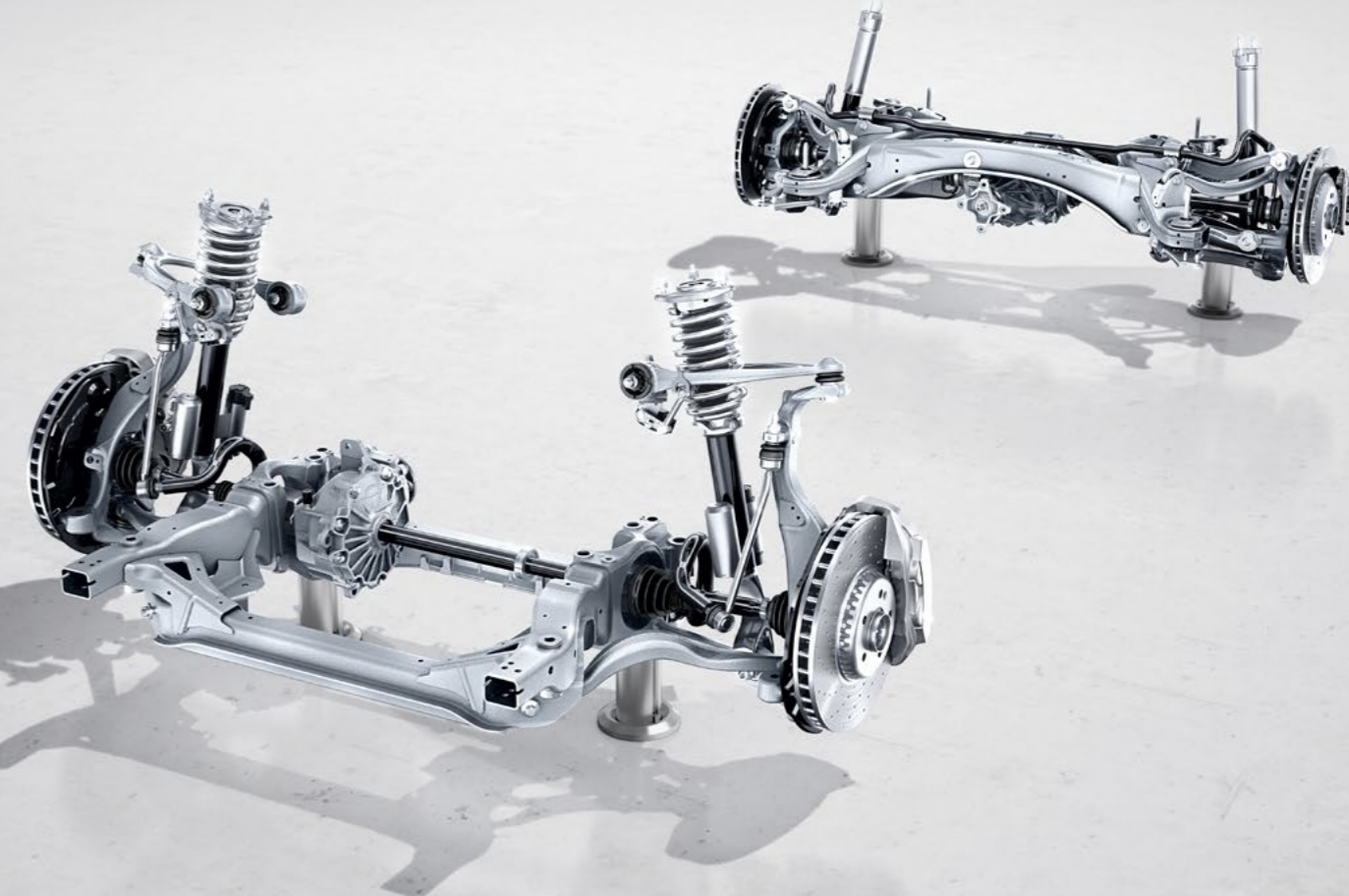

Do another lap.

Adapt the new E-Class Coupé to suit your preferences perfectly: the flexible DYNAMIC BODY CONTROL suspension has three set-ups, ranging from maximum agility through to superb ride comfort. The AIR BODY CONTROL air suspension system ensures comfortable motoring even on bumpy roads.\*

\*DYNAMIC BODY CONTROL suspension optionally available for E200, not available for other models. AIR BODY CONTROL air suspension not available for E200, standard for other models.



# Made to win the night.

Every Mercedes-AMG is a masterpiece in its own right, with an unmistakable character. What unites our performance vehicles and sports cars is their irrepressible sporting spirit. Their passion for top performance. It is generated at the point where engineering skill meets a very special attitude: the spirit of AMG. We believe that you have to keep on challenging limits in order to achieve new goals. We accept nothing as a given. Because limits are imposed by people, and it's also people who can overcome them. It's this attitude that enables us to achieve outstanding performance for the race track – and for the road.

Welcome to the world of AMG.

[www.mercedes-amg.com](http://www.mercedes-amg.com)

**AMG**  
DRIVING PERFORMANCE





## Technical data.

Displacement (cc)
Rated output (kW [hp])
Acceleration from 0 to 100 km/h (s)
Fuel consumption <sup>4</sup> (l/100 km)
Urban
Extra-urban
Combined
Combined CO <sub>2</sub> emissions (g/km)

### Petrol engines

E 200	E 350	E 53 4MATIC+
1991	1991	2999
145 [197]	220 [299]	320 [435]
7.6	5.9	4.4
10.5	10.3	12.0
6.4	6.1	7.6
7.9	7.7	9.3
178	174	211

The best for the engine:  
Mercedes-Benz genuine engine oils.

The declared fuel consumption figures are determined by testing under standardised laboratory conditions in accordance with ADR 81/02. The fuel consumption figures stated are for the purposes of comparison amongst vehicles tested under the same technical procedures only. Real world energy consumption figures may vary and are influenced by many additional factors such as, individual driving style, load, traffic, ambient temperature and vehicle condition.

## Dimensions.

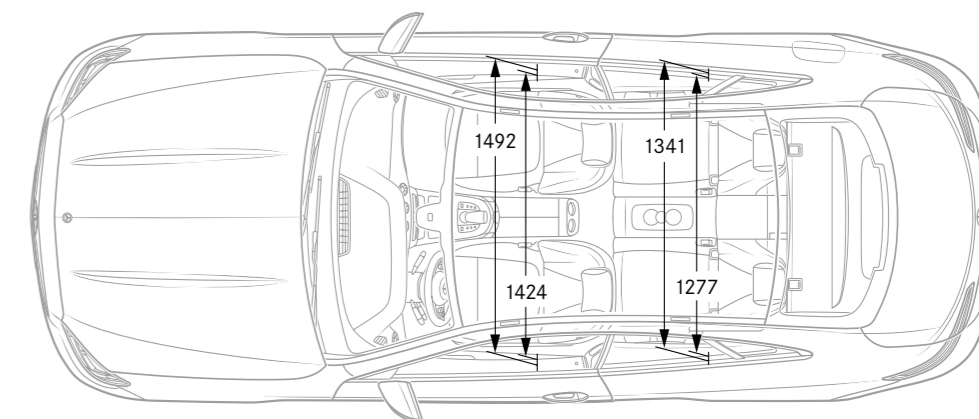
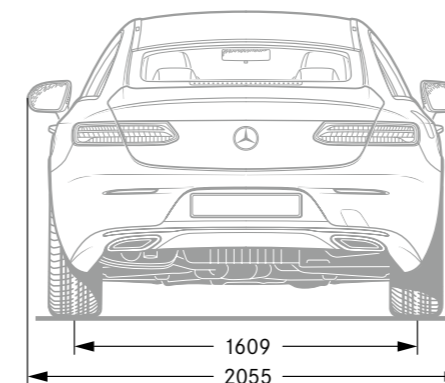
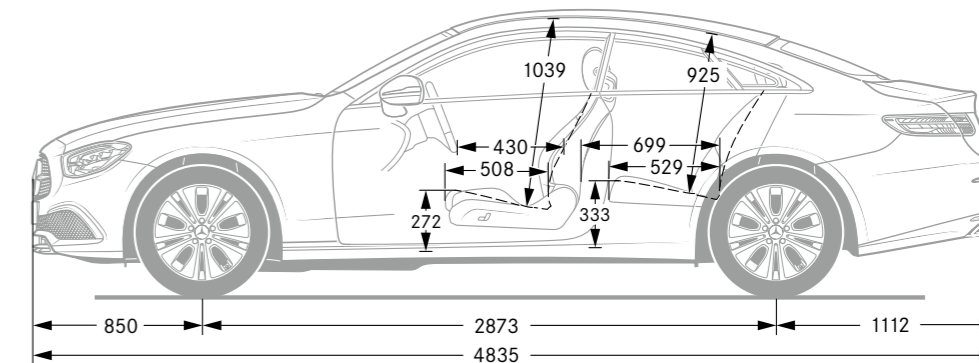
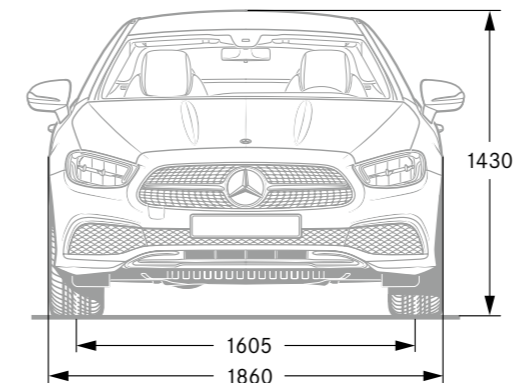

All figures in millimetres. The pictured dimensions are mean values. They are valid for vehicles in basic specification and in unladen condition.





# SPORT — F O R — GOOD

Mercedes-Benz AG is one of the founding partners of the worldwide “Laureus Sport for Good Foundation”, which was established in 2000. It is the Mercedes-Benz brand’s most important social initiative. Laureus Sport for Good supports children and young people in need through social sports projects, opening up new perspectives and imparting important values such as team spirit, respect and determination. “Change the Game for Kids” is our mission statement which we wish to share with you. In buying a Mercedes-Benz you are supporting the “Laureus Sport for Good” movement.

**Please note:** About the information in this publication: Changes may have been made to the product since the editorial deadline on 19.03.2020. The manufacturer reserves the right to make changes to the design, form, colour and the delivery scope during the delivery period, provided these changes, while taking into account the interests of the seller, can be deemed reasonable for the buyer. Where the seller or the manufacturer uses symbols or numbers to describe an order or the subject of an order, no rights may be derived solely from these. The illustrations may also show accessories and optional equipment, which are not part of the standard delivery scope. Therefore, please ask your Mercedes-Benz sales representative about the provisions and effects applicable in other countries and about the latest definitive version. [www.mercedes-benz.com.au](http://www.mercedes-benz.com.au)