

There's nothing newer in the world!



Proved and approved around the world

1958 FORD FAIRLANE *and* FAIRLANE 500

There's nothing newer in the world!

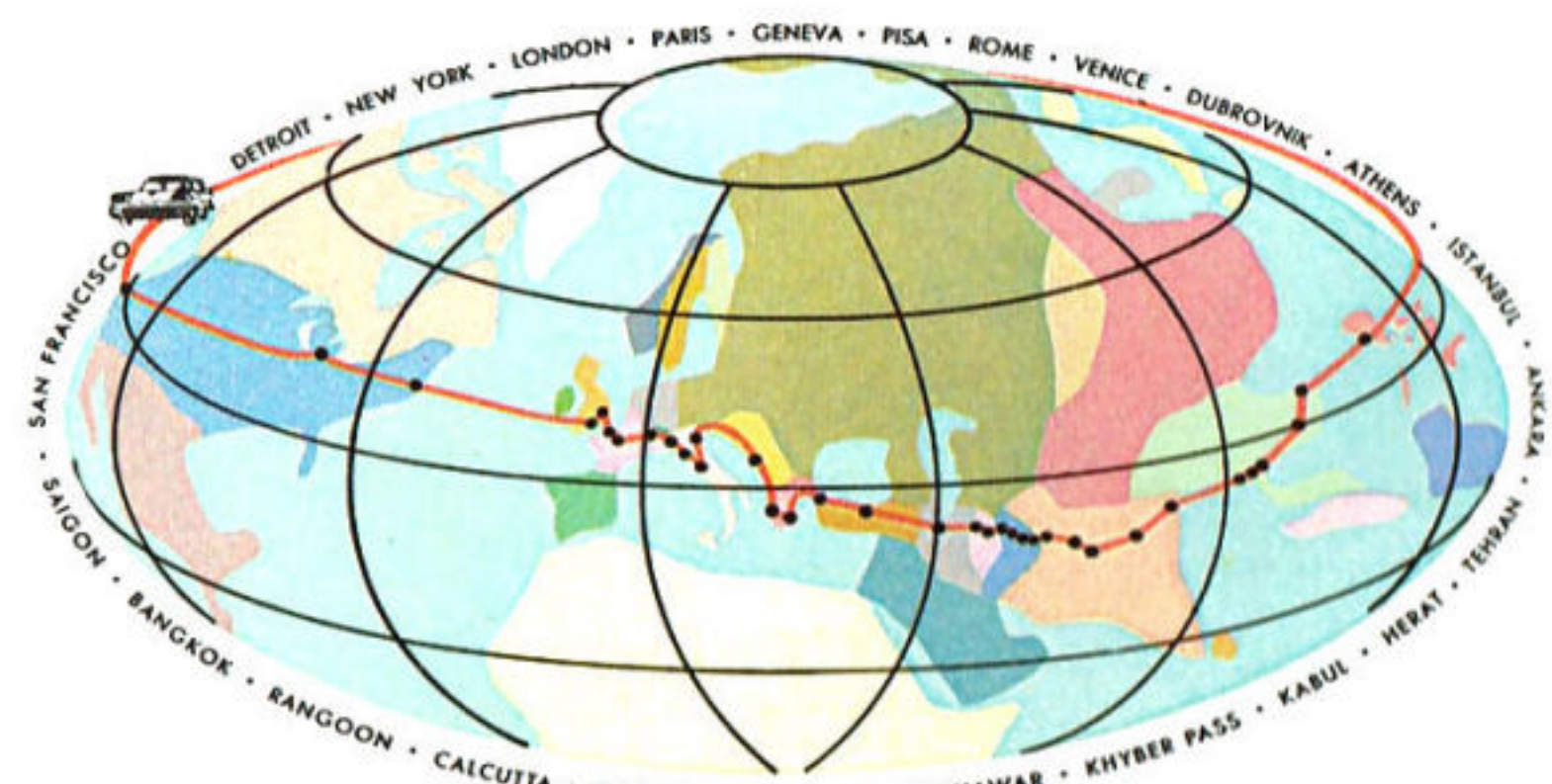

PROVED AND APPROVED AROUND THE WORLD

Never in the long and spectacular history of the American automobile industry has a new car faced the pre-announcement challenge that was put to the 1958 Ford . . . a road test over the roughest terrain that could be found on three continents!

The Thunderbird-inspired Ford for 1958 was driven around the world to prove its stamina and performance—the toughest pre-announcement road test ever given an automobile.

Months before it was announced, a new Fairlane 500 left Detroit, headed East. Its sudden appearance in England left staid Britishers gasping. Across the Channel it breezed into style-conscious Paris, where overnight its glamorous lines and thoroughbred performance made it the toast of the town.

But the real tests lay ahead—steep winding passes of the Swiss Alps . . . murderous back roads in the Balkans . . . broiling wastes of the Middle East . . . "goat tracks" in Central Asia . . . the steaming jungles of the Far East. Yet Ford passed each test with flying colors.

When this grueling round-the-world test was over, the 58 Ford had *proved* itself as had no other car in the long history

of automobiles. And now this same Thunderbird beauty, brawn, power and economy can be yours in every Ford Fairlane or Fairlane 500.

These newest of all Fords GO like no other Ford cars have ever gone—thanks to their new Thunderbird-powered Interceptor V-8 engines. Totally new for '58, these mighty power plants range up to 300 horsepower! They're the biggest engines in Ford's field. And they're the most efficient engines in Ford's 25 years of V-8 leadership—thanks to new Precision Fuel Induction. What's more, you'll save up to 15% on gas, too, when you team new Cruise-O-Matic Drive with Interceptor V-8. A gas-saving rear axle ratio (just 2.69 to 1) provides "built-in" overdrive economy!

Wonder of wonders, all this can be yours at low Ford prices.

Truly, there is nothing newer in the world!

Fabulous new Thunderbird seats four! Now T-bird fun can be a family affair! This dream-car-come-true brings you famed Thunderbird distinction . . . Thunderbird safety and maneuverability . . . exciting Thunderbird performance—and now with full fine-car roominess and luxury, too! Here is the year's most talked-about car. And remember—there's Thunderbird magic in every Ford!

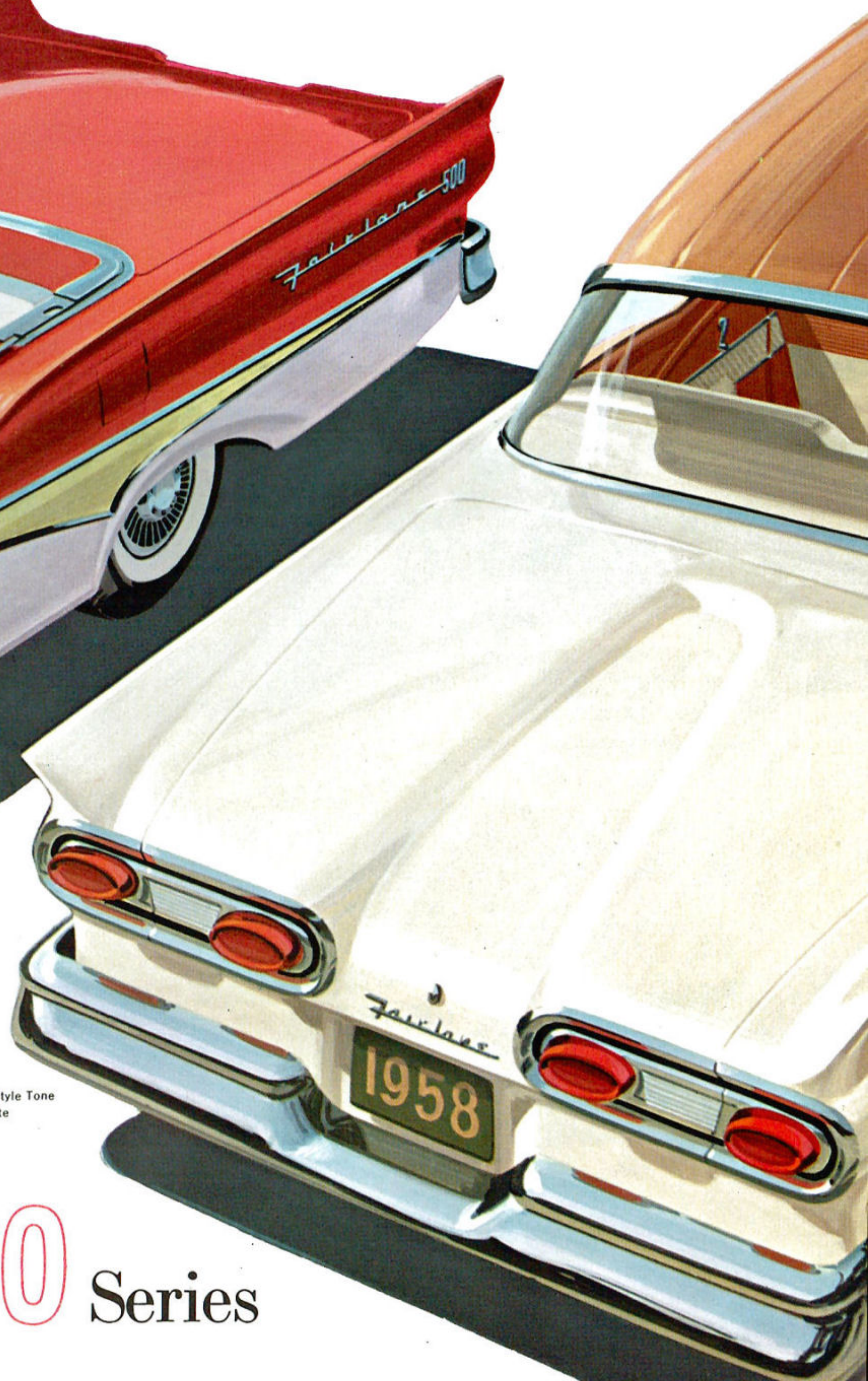

Fairlane 500 Club Victoria in inverted Style Tone of Palomino Tan and Colonial White

Fairlane 500 Skyliner in Style Tone combination of Colonial White and exclusive new metallic Grenadier Red

Presenting the FAIRLANE 500 Series



A touch of your finger . . . and away she goes . . .

Just touch a button . . . in less than a minute the all-steel hard top vanishes smoothly into the rear deck . . . and you're sitting pretty in Ford's great Skyliner—the car that the “ex-perts” said could never be built! Here indeed is an engineering triumph in the best Ford tradition.

The Skyliner is the world's only retractable hardtop. And the fact that Ford—and *only* Ford—was able to create and produce this amazing car is important to you. For all the exhaustive research, planning and testing that went into the Skyliner is dramatic proof of the engineering skill you get in every Ford model.

Luggage room to spare!



Top up, you'll find a vast “cavern” of luggage space—actually enough room to store all of your baggage for a three-week cross-country trip.

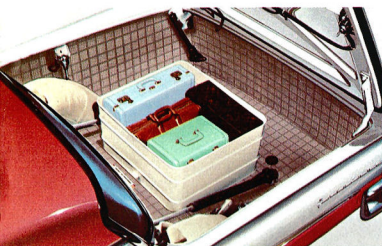

Top down, there's plenty of room for all of your weekend luggage in a special protective metal storage compartment in the big Skyliner trunk.

from steel hardtop . . .

At first glance you might take this Skyliner for a new and distinctively different hardtop—a handsome all-weather car—as snug and safe as a steel hardtop can be. And this Skyliner is all of that! But what hardtop ever had a control on the instrument panel marked “Top”?

automatically

Touch the magic control, and synchronized electric motors go to work . . . quietly . . . dependably. Locking screws that secure the roof to windshield and body untwist . . . automatically! The roof swings back, vanishes smoothly out of sight into the rear deck. The deck lid closes—flush—and locks itself tightly in place.

. . . to open convertible

Now you're sitting pretty for sun and fun, Ford convertible style. But should the clouds threaten, just touch the magic control again. In less than sixty seconds the roof is back in place and locked solid to let you laugh at the worst of wind and weather.

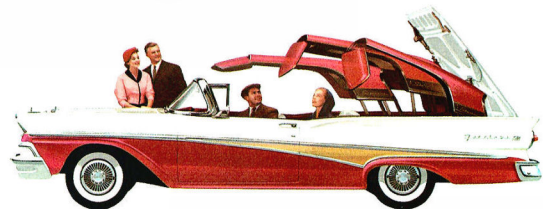

FAIRLANE 500 *Skyliner*

Presenting the 1958 Skyliner . . . a still newer, more glamorous version of the miracle car of our generation. It's the world's *only* all-steel hardtop convertible . . . another example of the engineering leadership you get in *every* Ford. You'll find the Skyliner is very reasonably priced. In fact, a comparison of manufacturers' suggested retail prices shows only four "soft top" convertibles (including a Ford) are priced less than the Skyliner.



The Skyliner in inverted Style Tone color combination

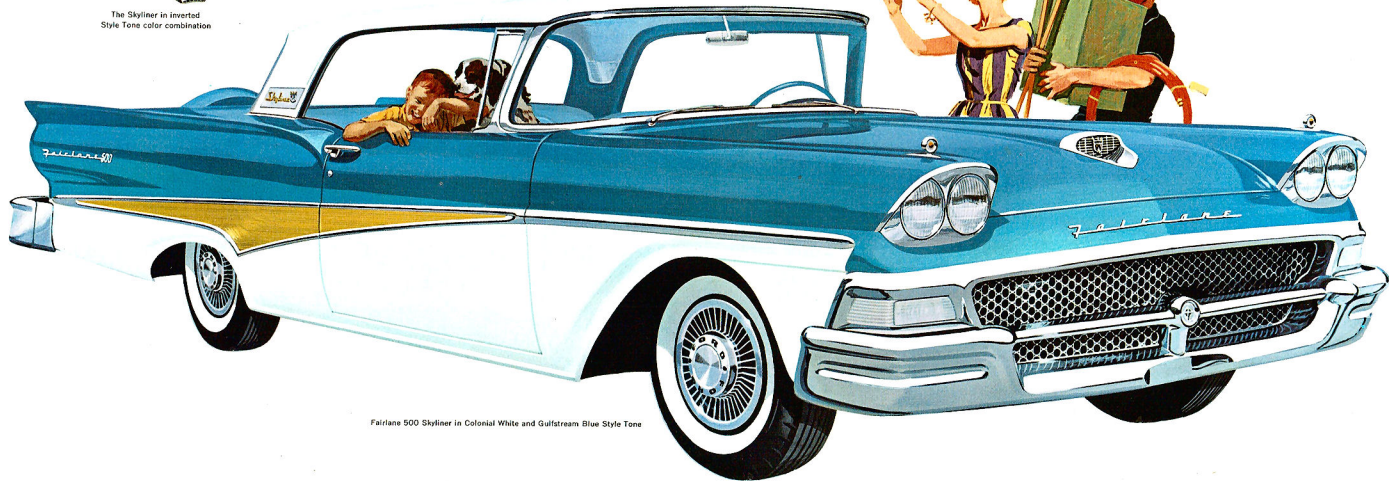

Fairlane 500 Skyliner in Colonial White and Gulfstream Blue Style Tone

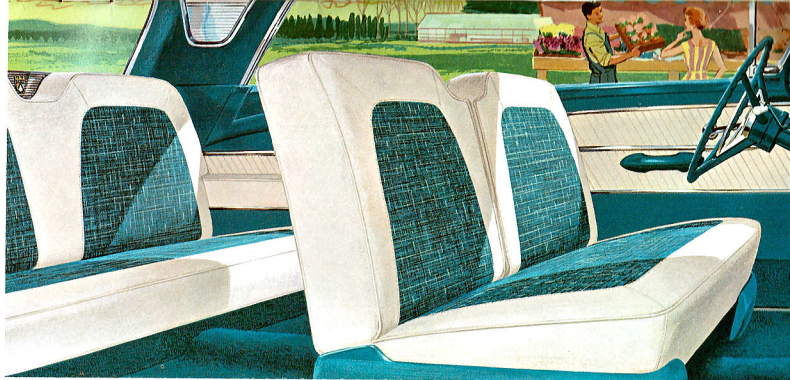

All-new for '58, Ford's elegant, color-keyed Luxury Lounge interiors are shown in all their splendor in the Skyliner.

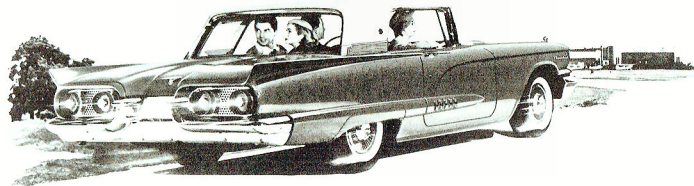

New Thunderbird-powered Interceptor V-8's with Precision Fuel Induction

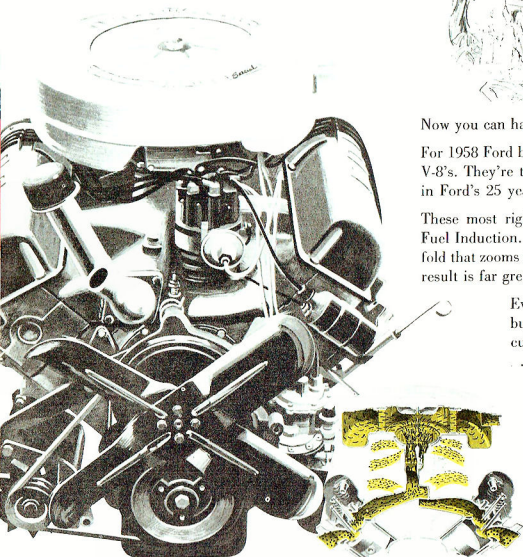

All-new 300-hp Interceptor 332 Special V-8 engine with 4-barrel carburetor is the finest engine ever produced for the Ford car. Built by the world's most experienced builders of V-8's, it delivers its maximum thrust at normal everyday driving speeds. No other engine in its class gives more smoothness or greater economy. An optional engine with Fairlane and Fairlane 500 models.

How Precision Fuel Induction works is shown here. Fuel-air mixture flows more freely, more precisely from the carburetor through 8 expressways to deliver the most uniform charge possible to each combustion chamber. Freer breathing means more power, smoother performance and more "go" on less gas.



Now you can have *Thunderbird* power in the Ford of your choice!

For 1958 Ford brings you an entirely new series of V-8 engines—Ford Interceptor V-8's. They're the biggest engines in Ford's field . . . the most advanced engines in Ford's 25 years of V-8 leadership!

These most rigid V-8's ever bring you a totally new engine feature: Precision Fuel Induction. It's a new fuel-feeding system with an "expressway" intake manifold that zooms the fuel-air mixture *directly* from carburetor to cylinder heads. The result is far greater power, smoother performance and better operating economy!

Every Interceptor V-8 features new machined wedge-shape combustion chambers to polish off every bit of power from every molecule of fuel . . . larger displacements . . . higher compression ratios . . . greater horsepower . . . higher torque and more compact design.

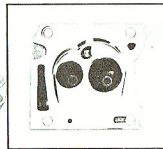
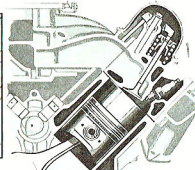
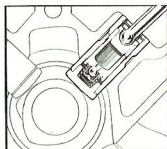

Hydraulic valve lifters are self-adjusting for zero lash in all Interceptor V-8 engines for 1958. This gives you not only the smoothest but also the *quietest* of engines. And because the valve lifters adjust automatically, there's no need to set tappet clearances during engine

tune-up. In addition, new wedge-shape combustion chambers (right) have *machined* surfaces so that volume is equalized for more uniform power output from each cylinder. The result—more efficient combustion . . . greater economy . . . smoother power.

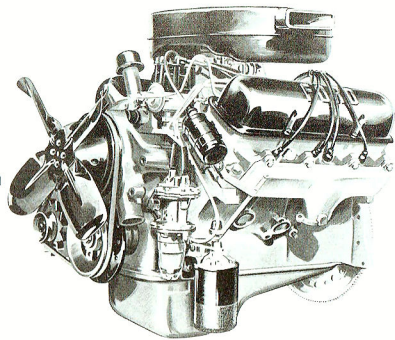

All-new 265-hp Interceptor 332 Special V-8 with 4-barrel carburetor is an optional V-8 in Fairlane 500 models. It delivers maximum performance from regular gasoline to give you extra savings. From its rigid, Deep-Block design to its rim-bolted valve-rocker covers, every feature contributes to smoother, quieter operation and greater over-all durability.

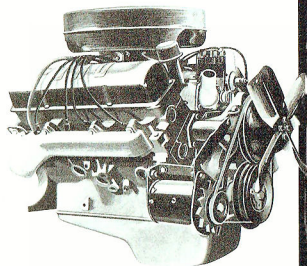

All-new 240-hp Interceptor 332 V-8 with 2-barrel carburetor is optional in Fairlane 500 models. A brilliant member of the new Interceptor V-8 family, it raises standards of engine efficiency and economy to a new level—and does it on regular gas, too. Short-stroke design and precision fit of all moving parts cuts horsepower-wearing friction and reduces engine wear.

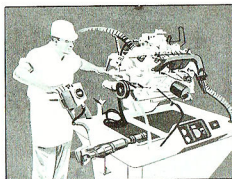

All Ford V-8 engines are electronically balanced while running under their own power before being mounted in the car. With vibration damped out, they run far smoother and last far longer.

FAIRLANE 500 *Town Victoria*

So low . . . so lively . . . and OH, so lovely . . . here's the beauty queen of the hardtops! The luxury of the Fairlane 500 Town Victoria's appointments and riding comfort are in a class once reserved for the highest-priced cars alone. With its wide-open Victoria look, 4-door convenience and spacious interiors, this glamour car is a standing invitation to go places and do things. And go it will, with the smooth, spirited action of its ultra-modern, Thunderbird-powered Interceptor V-8. You'll ride in the most silent, solid comfort imaginable, thanks to the shock-absorbing design and enormous strength of the new "Inner Ford" that lies beneath the stunning beauty of every Ford for '58.

Lovely to look at, easy to live with. These sparkling Luxury Lounge interiors are tailored from handsome fabrics in an attractive array of colors. Beauty surrounds you in the '58 Ford!

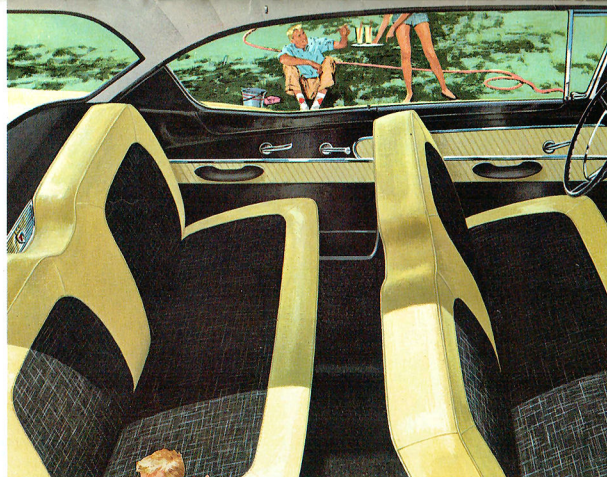

A crown of stainless steel circles the windshield with its smart Sweep-Back Pillars.

Sculptured metal panel brightens the gracefully contoured corner where top meets body.

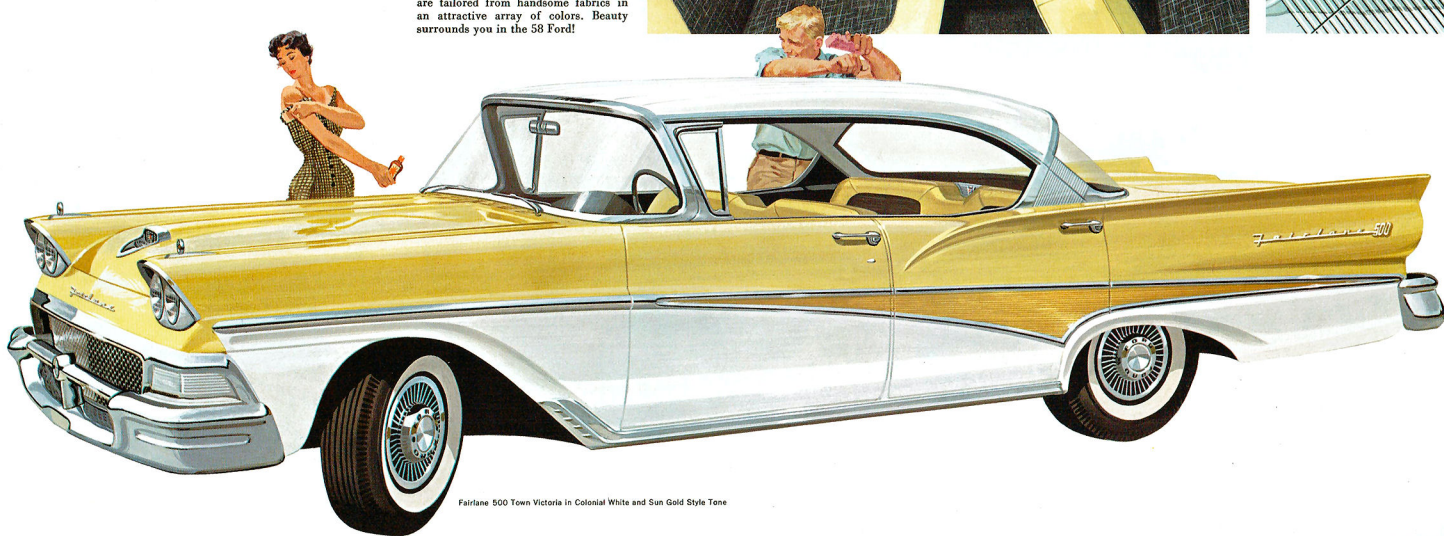
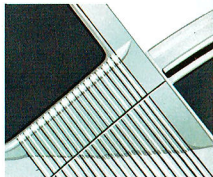

Fairlane 500 Town Victoria in Colonial White and Sun Gold Style Tone

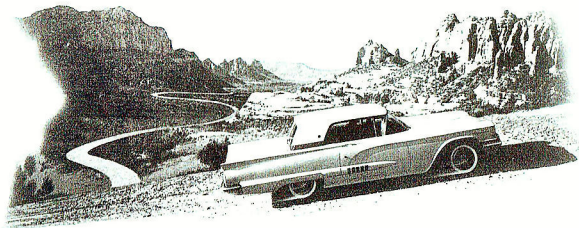

IT TURNED A SEA OF SAND INTO A SUPERHIGHWAY!

New Cruise-O-Matic Drive is the newest, thriftiest, most versatile automatic transmission going

The shifting sands of the Iranian deserts have a way of blotting out roads. But the pioneering Ford Fairlane 500 with its Cruise-O-Matic Drive forged ahead easily . . . making its own roads where there were none. It turned searing sands into a passable highway!

New Cruise-O-Matic Drive brings you all the smoothness and quietness of a torque converter, blended with the efficiency of planetary gears. It provides fully automatic operation in two selective driving ranges. Just set it in the new "D1" position and you'll discover how re-

sponsive, how *solid*-feeling a start can be. There's never any hesitation . . . never any "glue-pot" sensation.

And with Cruise-O-Matic, the final drive ratio is almost the same as that of a Ford with Overdrive transmission. In effect, all the savings and smooth quiet performance of an Overdrive transmission are "built-in"!

Most surprising of all, Cruise-O-Matic is the lowest-priced premium-performance automatic transmission you can buy!

Choose from 4 Great Engines . . . 4 Terrific Transmissions

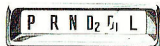

New Cruise-O-Matic Drive gives you the right GO for every driving range. "D1" starts you in low for full power getaways. "D2" starts in intermediate for sure-footed acceleration on ice or gravel.

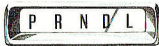

New Fordomatic Drive is advanced to give smoother than ever downshifting from direct to over-mediate. It features three forward gears that let you start normally or extra fast as you desire.



Overdrive is a combination of standard 3-speed transmission and an automatic 4th gear. It lets the engine loaf while the car is traveling at normal touring speeds, saves gallons of gas on long trips!



Conventional Drive gives you the quietest manual shifting obtainable anywhere. It features gear ratios that are exactly tailored to the needs of each engine for top performance and economy.

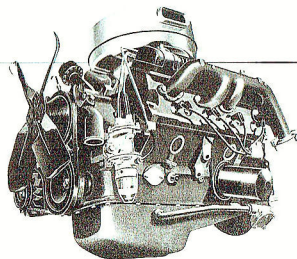

Ford 292 V-8 with 205 hp has new higher-velocity carburetion that gives greater gas-saving efficiency on regular gas. It has new positive engine ventilation system . . . plus other time-proven Ford features. It's the standard V-8 on Fairlane and Fairlane 500 models.

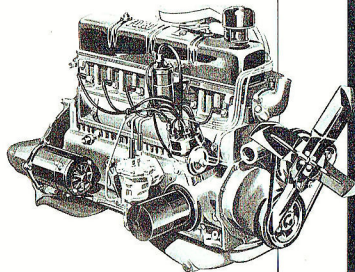

Ford's 145-hp Mileage Maker Six is the most powerful *modern* 6-cylinder passenger car engine you can buy, yet it saves and saves on gas! And now new timing and carburetion advances give up to 10% more fuel economy on regular gas. You just can't beat it for thrifty, lively performance! Available in all models except Skyliner.

ENGINE	TRANSMISSION	MODELS
145-hp Mileage Maker Six	3-Speed, Overdrive or Fordomatic	Fairlane and Fairlane 500 except Skyliner
205-hp Ford 292 V-8	3-Speed, Overdrive or Fordomatic	Fairlane
	3-Speed or Overdrive	Fairlane 500
240-hp Interceptor 332 V-8	Fordomatic	Fairlane 500
265-hp Interceptor 332 Special V-8	Cruise-O-Matic	Fairlane 500
300-hp Interceptor 352 Special V-8	3-Speed, Overdrive, Fordomatic or Cruise-O-Matic	Fairlane and Fairlane 500

FAIRLANE 500 *Club Victoria*

An impulsive "WOW!" describes the way most people feel when they first see this dashing member of the Ford Victoria family. The poised-for-flight thrust of its side trim, the flowing sweep of its canted tail fins, give exciting promise of the mighty Interceptor V-8 power beneath its long, low hood. The completely new and distinctive Safety-Twin taillights are as functional as they are beautiful, and harmonize perfectly with the new Safety-Twin headlights. Another design innovation is the new deeply sculptured rear deck that complements the new Power-Flow hood.

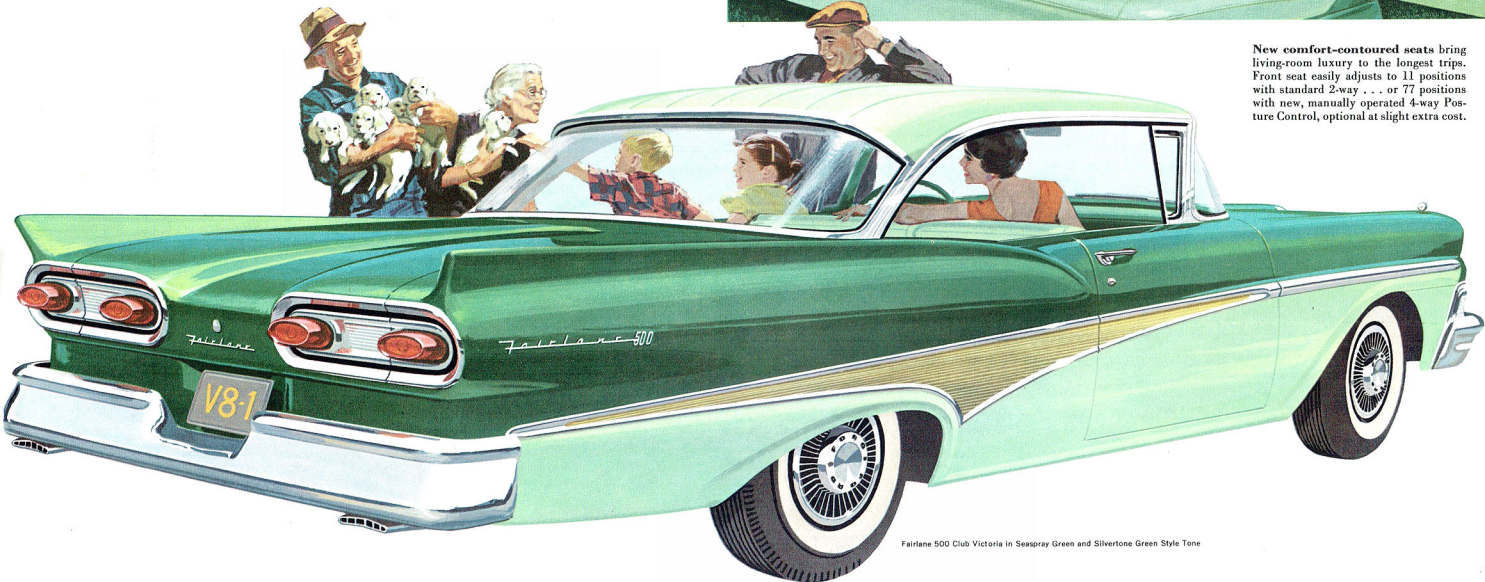
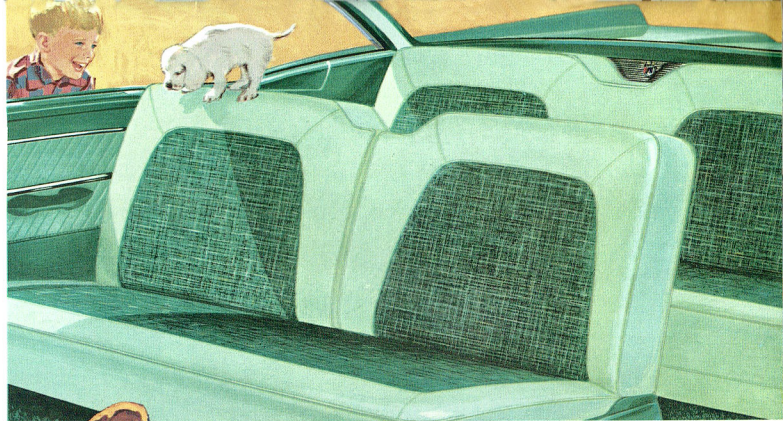

New comfort-contoured seats bring living-room luxury to the longest trips. Front seat easily adjusts to 11 positions with standard 2-way . . . or 77 positions with new, manually operated 4-way Posture Control, optional at slight extra cost.

Fairlane 500 Club Victoria in Seagray Green and Silvertone Green Style Tone



HOW BUMPS IN BANGKOK LOST THEIR BOUNCE

The roughest going can't make a dent in the solid, silent comfort of the 58 Ford. There's nothing like it in the whole ride world!

Constant joggling, swaying, bouncing and vibration can take the fun out of *any* trip. But the 58 Ford laid such a thick carpet of comfort over the roughest roads on three continents that its drivers reached Bangkok none the worse for wear . . . enjoyed the stately Buddhist temples, hardly noticing the rough cobbled streets.

Ford comfort starts with its exclusive frame. It has a wide-base design that lowers the center of gravity for greater stability . . . seats passengers safer, *within* the protection of the massive wide-contoured frame side rails.

Ford's ball-joint front suspension rides easier than ever with new lubed-and-sealed bushings on the upper control arms. Exclusive angle-poised coil springs and swept-back control arms "roll with the punch" of any bump. The Even-Keel rear suspension combines a far softer action with level-ride control. Silent-Grip body mounts soak up chassis shock and noise.

And for the *ultimate* in riding comfort, the new 58 Ford offers you the latest type air suspension—*Ford-Aire Suspension*. It's like riding on a cloud! Try it and you'll agree . . . there's nothing more gentle in the world.

There's Thunderbird magic in every Ford
... that's why it's more fun to go Ford!



FAIRLANE 500 *Sunliner*

America's all-time favorite convertible . . . the one and only Ford Sunliner . . . more lovely—with 58 Ford Styling—and more lively than ever. It's an open invitation to fun in the sun. The trim soft top nests smoothly into its own compartment ahead of the rear deck. And if the clouds darken, the roof can be raised in seconds to speed you on your way in weatherproof comfort. The new Sunliner rides sedan-silent on a brawny, full-cradle frame made still more rigid by a hefty X-member. And with new front and rear suspension, the going's always great, in *any* kind of going.

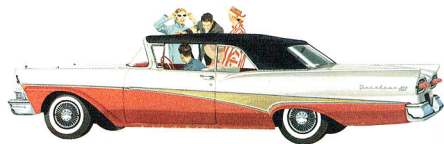

Sunliner in inverted Style Tone color combination. Choice of white vinyl, tan or black fabric soft top

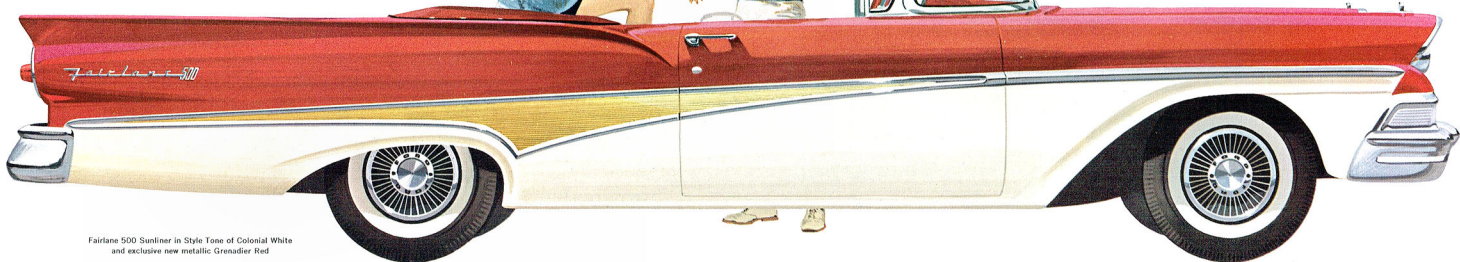
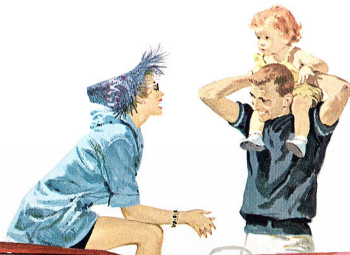

Fairlane 500 Sunliner in Style Tone of Colonial White and exclusive new metallic Grenadier Red



New Power-Flow hood ornament symbolizes the styling of the '58 Ford, sets it apart from other cars!

New Safety-Twin headlights make night driving safer than ever before.



Inside beauty matches outside glamour in more ways than one. Whatever colors you choose, Ford blends them into a subtle scheme that delights the eye and makes you proud to be a Ford owner. Even the textured floor mats harmonize with the trim and fabric colors to welcome you into the lap of fine-car luxury. It's easy as pie to keep this beauty bright as new.

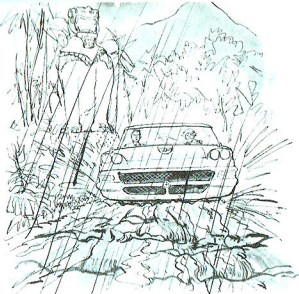

Air cylinders at each rear wheel replace conventional steel springs. Your ride is softer, quieter, more comfortable.

Air compressor, driven by engine, supplies air at a pressure of 300 pounds per square inch to operate new Ford-Aire Suspension.

Air reserve tank provides a reservoir of high pressure air to keep the system operative whether engine is running or not.

Leveling valves, one at each front wheel, operate automatically to keep car's front-end height constant regardless of amount or location of load.

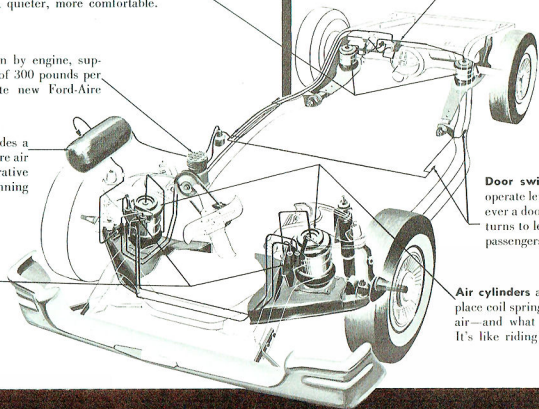

A TRUE AIR RIDE with new Ford-Aire Suspension!

Leveling valve at rear axle operates automatically to maintain constant height at rear of car. Now, a trunk full of luggage no longer leaves you riding front-end high, rear-end low.

Door switches at all doors operate leveling valves whenever a door is opened. Car returns to level instantly when passengers get in or out.

Air cylinders at each front wheel replace coil springs. You literally ride on air—and what a difference it makes. It's like riding on a cloud!

Now you can literally ride on air . . . and what a world of difference it makes!

Four nylon-rubber air cylinders replace front coil springs and rear leaf springs. An engine-driven compressor and a reserve tank provide ample air pressure supply. Operation of the system is completely automatic.

Air cushioning action is uniform under

all road and load conditions. A two-speed, self-leveling system automatically levels the car regardless of weight or location of load.

Ford-Aire Suspension is available at extra cost in all Fairlane and Fairlane 500 models with Interceptor V-8 engine and automatic transmission. It gives you a level, luxurious air-ride unsurpassed by even the highest-priced cars!

Levels in seconds when you open door!



Load the luggage compartment to the hilt or pile in the passengers. But the instant you open a door, Ford-Aire Suspension's fast-

leveling action automatically expands the rugged nylon-rubber air cylinders . . . returns the car to level in seconds.

Rounds curves with minimum swing or sway!

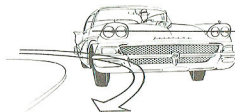

The automatic balancing action of new Ford-Aire Suspension gives excellent roll control in cornering. You get sure handling around curves with almost no swing or sway.

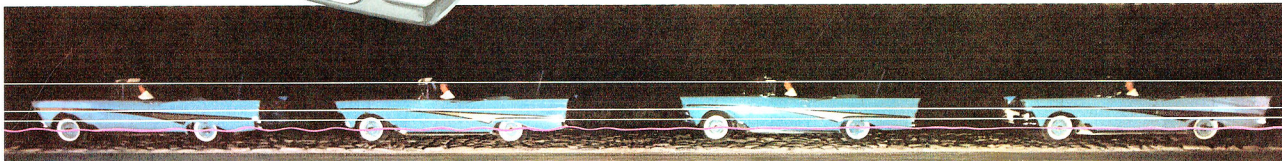

**Riding on Ford-Aire
Suspension is like
riding on a cloud!**

Smothers bumps on a cushion of compressed air!

Ford-Aire Suspension soaks up road shocks before they reach you (see actual test photo above). You get the restful, luxurious comfort once associated only with the heaviest, costliest cars. You get the same smooth, air-soft ride driving by yourself on a bumpy road or cruising

down an expressway with six passengers aboard. This is possible because the automatic slow-leveling action compensates for changes in load and ride conditions while the car is *in motion!* Riding on Ford-Aire Suspension is like riding on a cloud!

FAIRLANE 500 *Town Sedan*

This solid, silent 4-door sedan sits firmly in a fine-car class all its own. Boasting a startlingly low, road-hugging silhouette, it's also built for graceful entries, easy exits. Its handsome thin-pillar, "hardtop" styling is as practical as it is beautiful. Inside, entirely new color-keyed Luxury Lounge interiors (right) with nylon upholstery in exclusive Damask and Shadow-Block patterns, and Luxury-Loom carpets are even more beautiful. They give you living-room luxury—on wheels. No wonder Paris was impressed.

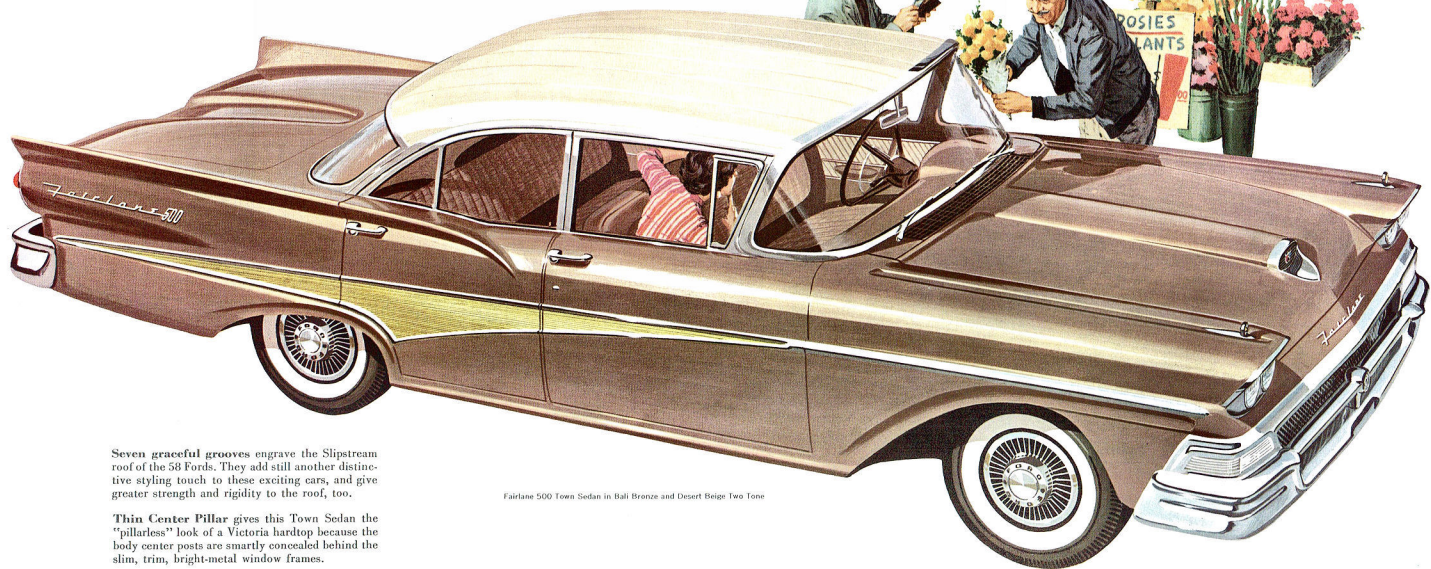
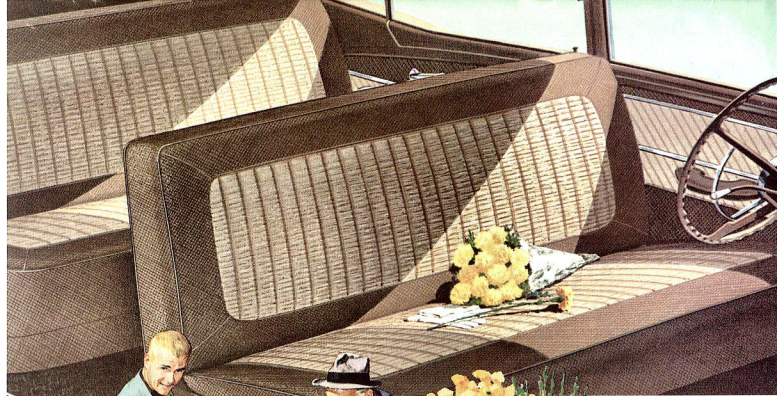

Seven graceful grooves engrave the Slipstream roof of the 58 Fords. They add still another distinctive styling touch to these exciting cars, and give greater strength and rigidity to the roof, too.

Thin Center Pillar gives this Town Sedan the "pillarless" look of a Victoria hardtop because the body center posts are smartly concealed behind the slim, trim, bright-metal window frames.

Fairlane 500 Town Sedan in Ball Bronze and Desert Beige; Two Tone

New Magic-Circle Steering

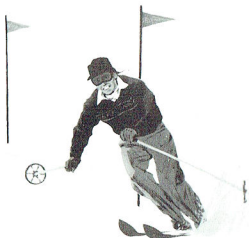

It's practically friction-free!

Recirculating steel balls are the secret of the new Ford's handling ease. These free-moving steel balls in the new Magic-Circle steering gear are practically friction-free, operate far more easily than the con-

Handling ease with the Thunderbird touch!

The countless switchback turns of the steep Himalayan roads often twist a frightening 180° . . . make a stern test of car and driver with no mistakes allowed. Yet the driver who wheeled the flying Ford Fairlane 500 over the Khyber Pass and into Pakistan said, "That run took no more effort than a Sunday afternoon drive at home. Ford's new Magic-Circle steering is really great!"

ventional worm gear mechanism. Ford's new Magic-Circle steering is the nearest thing yet to power steering. It turns difficult parking problems into child's play!

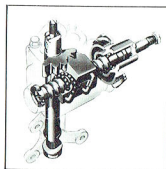

Free-moving steel balls, carrying a specially designed nut, replace the standard worm gear in new Ford Magic-Circle steering. These practically friction-free balls, together with anti-friction bearings on steering shaft, provide significantly easier, smoother steering.

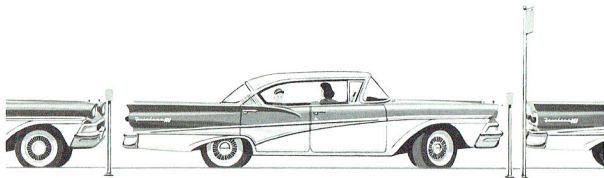

Tight parking is a breeze when you team new Magic-Circle steering with optional Master-Guide power steering that does up to 75% of the steering for you. This combination gives you the ultimate in easy handling and precise control. It makes all your driving

easy, makes even tight parking almost effort-free. Yet Magic-Circle steering is standard on all Fords . . . and Master-Guide *power* steering is the lowest-priced power steering you can buy. You can pay more . . . but you can't buy better!

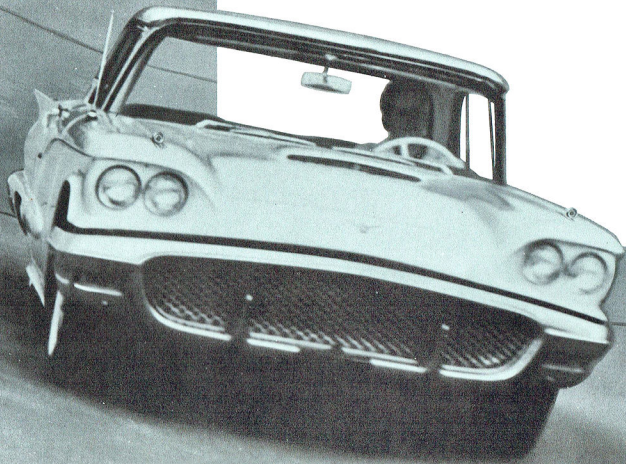

FAIRLANE 500 *Club Sedan*

Boldly modern in every way, this dashing 2-door sedan cheerfully doubles as a strictly sensible family car. Plenty of room for six. Plenty of room for a long vacation's load of luggage. The new Safety-Twin headlights give the whole car that years-ahead look . . . and help you drive in greater safety, too. The new Honeycombed grille is another master styling stroke from Ford. Made of long-lasting, clear-anodized aluminum, its "suspended circle" design is unique. The all-new, one-piece front bumper gives massive protection to the front and sides. Both the graceful grille guard and the smart Fashion-Ray wheel covers are standard on all Fairlane 500 models.

Front seat cushions are foam-rubber padded for still more comfort and luxury. Front seats are anchored firmly to the chassis for added safety. All Ford seats are designed to keep their comfort-contoured lines.

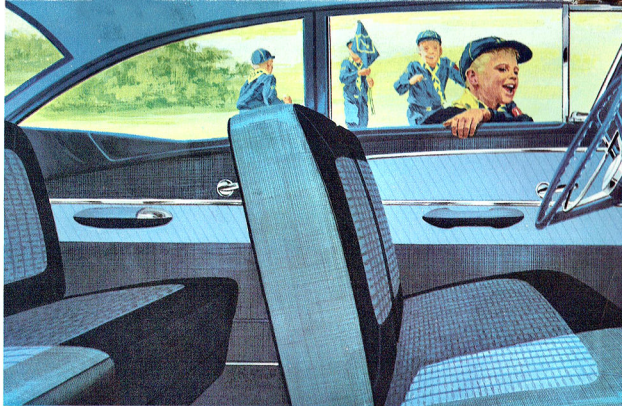

Exciting, all-new Safety-Twin taillights match the new Safety-Twin headlights in styling and practicality.

The door handles boast Ford's new flowing lines. They're double-anchored for extra strength.



The Fairlane 500 Club Sedan in regular Style Tone colors



Fairlane 500 Club Sedan in inverted Style Tone of Silverstone Blue and Colonial White

COLOR SELECTIONS

matched to your
personal taste and preference

For 1958, the thirteen exterior Fairlane and Fairlane 500 colors follow a theme of rich beauty. There's more sparkle to their high-lustre finish and a wider variety of exciting new metallics. Style Tone treatments, including Two Tone on Fairlane 500, let you join your favorite shades in their most tasteful combination.

Soft-hued interior trim and upholstery fabrics are skillfully keyed to your choice of exterior colors. The resulting harmony is worthy of the finest interior decorator working in the finest of homes.

Handsome Safety-Curved instrument panel (right) has new soft-textured, silver-satin finish trim. Self-regulating electric clock is standard on Fairlane 500 models; optional on Fairlanes.



Fairlane Club Victoria in Raven Black and Sun Gold Style Tone with optional Country Club Trim

Presenting the FAIRLANE Series

... four dramatically new fine cars from Ford

The brilliant Fairlanes are striking proof that there's nothing newer in the world than the 1958 Ford.

They offer the luxury and comfort of their dashing sister series, the Fairlane 500's. They share the 58 Ford Styling of the Honeycombed grille, Power-Flow hood, Slipstream roof and sculptured rear deck. To this they add a beautiful touch all their own . . . the graceful chrome ellipse that sweeps back from the headlights, plus a glamorous Country Club Trim option. Performance is breath-taking, economy is surprising with the great new 300-hp Interceptor 352 Special V-8 engine.

Handling is razor keen with new ball-type Magic-Circle steering—the next best thing to power steering!

In the new Fairlane Series you'll find a two-door and a four-door Victoria in Ford's famous pillarless style. Or you can choose a two-door or four-door sedan . . . both cleverly designed to give the graceful, open look of a real Victoria hardtop.

And remarkable as it may seem, the new Fairlanes with all their solid, fine-car value are surprisingly low priced!

Beneath the beauty lies the brawn of a new **INNER FORD**

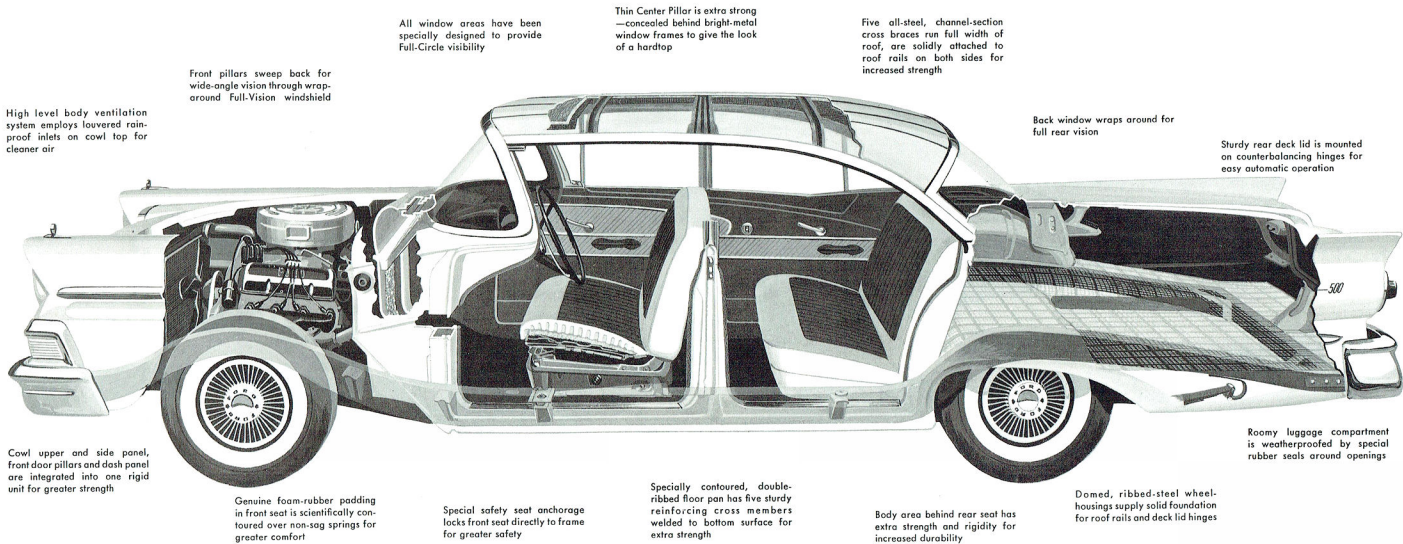

High level body ventilation system employs lowered rain-proof inlets on cowl top for cleaner air

Front pillars sweep back for wide-angle vision through wrap-around Full-Vision windshield

All window areas have been specially designed to provide Full-Circle visibility

Thin Center Pillar is extra strong—concealed behind bright-metal window frames to give the look of a hardtop

Five all-steel, channel-section cross braces run full width of roof, are solidly attached to roof rails on both sides for increased strength

Back window wraps around for full rear vision

Sturdy rear deck lid is mounted on counterbalancing hinges for easy automatic operation

Cowl upper and side panel, front door pillars and dash panel are integrated into one rigid unit for greater strength

Genuine foam-rubber padding in front seat is scientifically contoured over non-sag springs for greater comfort

Special safety seat anchorage locks front seat directly to frame for greater safety

Specially contoured, double-ribbed floor pan has five sturdy reinforcing cross members welded to bottom surface for extra strength

Body area behind rear seat has extra strength and rigidity for increased durability

Domed, ribbed-steel wheel-housings supply solid foundation for roof rails and deck lid hinges

Roomy luggage compartment is weatherproofed by special rubber seals around openings

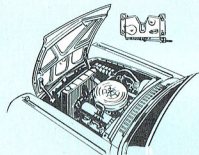

New front-hinged hood is spring-counterbalanced, has inner and outer panels welded into single unit for greatest strength.

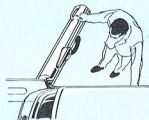

Sturdy offset door hinges permit front doors to be opened wider so you can get in and out easily.



2-stage door check holds the big front doors conveniently open at two points—two thirds or all the way.

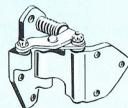

Automatic Doorman hinges take over when rear doors are half-open . . . help swing doors full-open or full-closed.



Double-Grip door locks rotate rather than slide into engagement for effortless ease of operation in all weather.



Roof insulation is a full half inch of fibrous sound-absorption material—far more than other cars in Ford's field.



Dash insulation consists of glass fibre, asphalt-impregnated felt and finish board—an inch thick.

FAIRLANE *Town Victoria*

If you like luxury, you'll love this big, beautiful Fairlane Town Victoria. With its wonderful "wide-open" hardtop styling and the convenience of four wide-opening doors, it's a handsome compliment to the fine taste and good judgment of its owner. It's lean, low and lovely to look at . . . and with a new Interceptor Special V-8 under the hood, it's packed with GO!

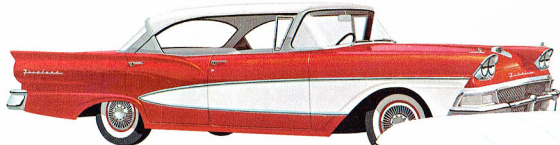

Fairlane Town Victoria in Style Tone of exclusive new metallic Grenadier Red with Colonial White and standard molding

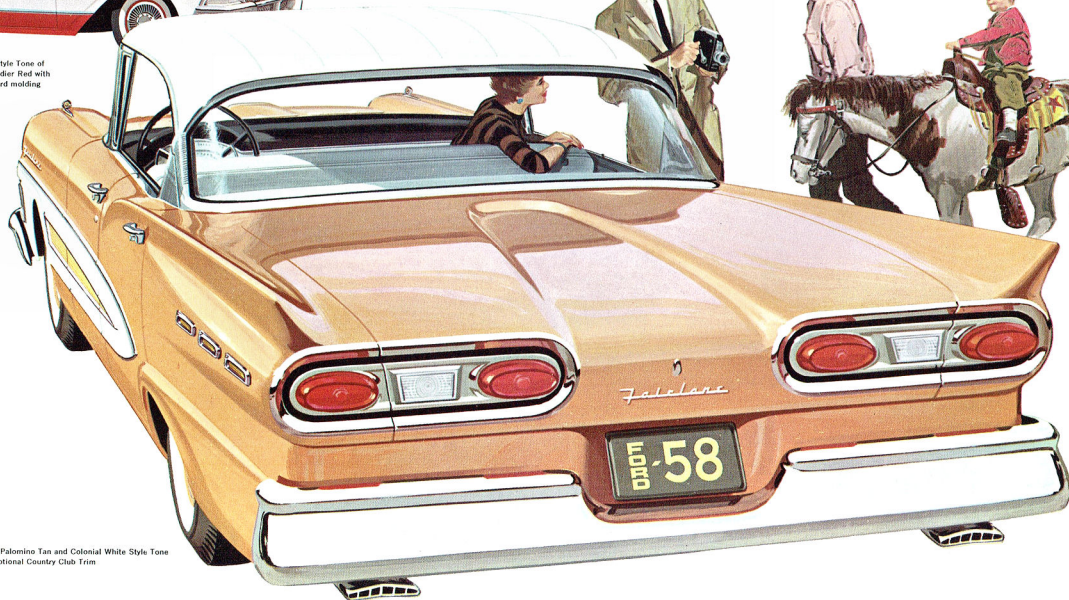

Fairlane Town Victoria in Palomino Tan and Colonial White Style Tone with optional Country Club Trim

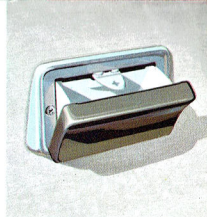
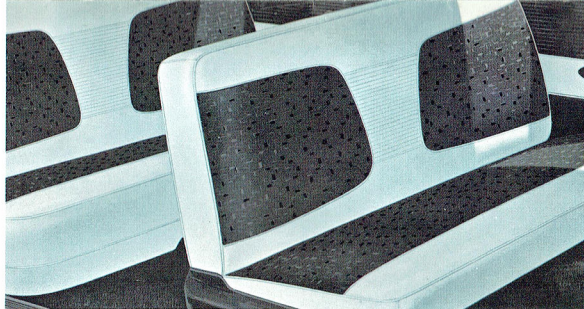

New ash trays are bin type. Conveniently located on instrument panel and in front seat-back, they're easier than ever to use.

HERE'S RUGGED PHYSICAL STAMINA

Ford's chassis for '58 is exclusive with Ford in its field. The husky frame side rails are contoured a full foot wider midway to extend *outside* the passenger seating area . . . gives strong protection in the event of side impact. *Five* sturdy cross members provide still greater strength and rigidity. The ride is far

softer, too, because Ford engineers have improved and softened Ford's famous 4-way ball-joint front suspension—as well as the variable-rate rear springs. Ford brakes for '58 are husky, king-size and double-sealed. They feature Ford's fixed-anchor design that requires only one simple adjustment.

Safety-Twin headlights make night driving safer



DRIVING—On high beam, all four lights are lit. Inner lights give highest intensity.



PASSING—You get low or passing beam from outer headlights. Inner lights are off.

A. Filaments for low beam are ideally located at focal center of reflector in outer lights. B. Outer lights have off-center filaments to help driving beam. C. Inner lights supply most of driving light with filaments ideally located at focal center of reflector.

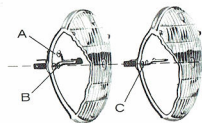

Ford Safety-Twin headlights give you a 25% increase in low beam wattage . . . a 50% increase in upper beam strength.

Picture at right (top) shows oncoming traffic with old-fashioned single-beam lighting.

Picture at bottom shows same scene, new lighting. With Ford's Safety-Twin headlights you see the tractor!



With Ford's Safety-Twin taillights . . . you can see the difference!

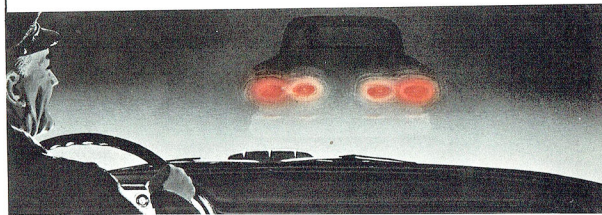

Men who know taillights best—truck drivers, police officers and others who travel America's highways—testify that Ford's Safety-Twin taillights keep you safer because dual lights are more *noticeable*. Besides when braking, outer lights glow

brighter than inner lights to give quicker, stronger warning to vehicles behind you, even in fog, rain or snow. Safety-Twin taillights are more than *twice* as large as those on competitive cars and they're more prominently positioned, too.

Only Ford offers you the safety of *twin* taillights on *all* models. On some competitive cars, backup lights *replace* one set of taillights, but on Ford cars backup lights are placed attractively *between* the twin taillights!

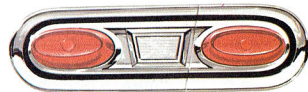

Safety-Twin taillight with backup light in center

FAIRLANE *Club Victoria*

Here you see to perfection the highlights of Ford's fresh, new styling for the Fairlane Series . . . the Power-Flow hood, the Safety-Twin headlights, the Honeycombed grille, the graceful chrome ellipse that sweeps back along the body from the headlights, and glamorous Country Club Trim. Just look at it sitting there, panther-trim and rarin' to take you where the fun is. And getting there is a treat all its own with the silent comfort and precise driving control of the rock-solid "Inner Ford."

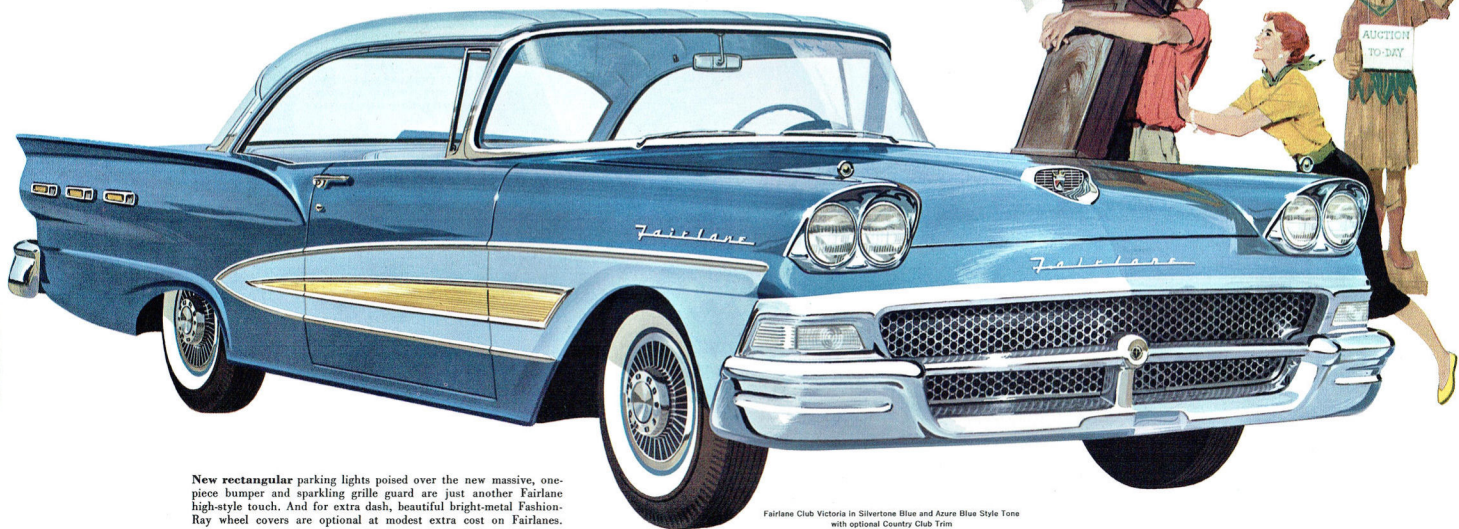
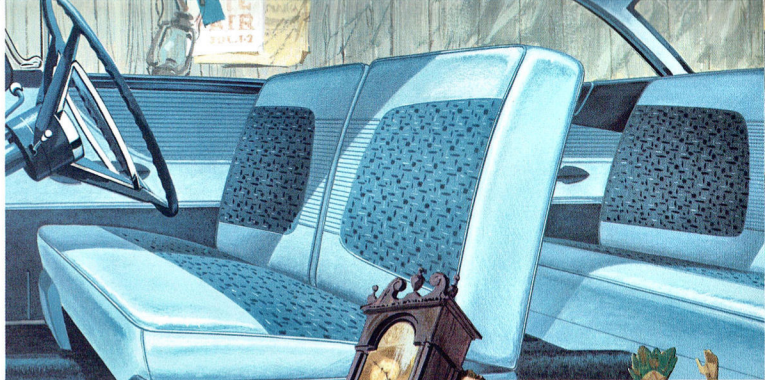

New rectangular parking lights poised over the new massive, one-piece bumper and sparkling grille guard are just another Fairlane high-style touch. And for extra dash, beautiful bright-metal Fashion-Ray wheel covers are optional at modest extra cost on Fairlanes.

Fairlane Club Victoria in Silverstone Blue and Azure Blue Style Tone with optional Country Club Trim



Select Aire Conditioner cools in summer, heats in winter—with just a flick of the dual lever control. Whole unit is located ahead of passenger compartment.



PolarAire Conditioner provides convenient, low-cost air conditioning. Simple controls make it easy to choose whatever cooling temperature you desire no matter how hot the weather.

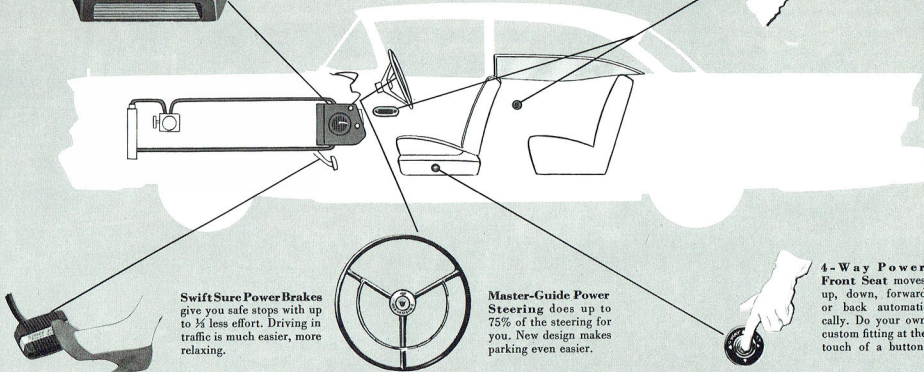

Power-Lift Windows are controlled by individual buttons at windows . . . and central control panel on driver's door.

Swift Sure Power Brakes give you safe stops with up to $\frac{1}{2}$ less effort. Driving in traffic is much easier, more relaxing.

Master-Guide Power Steering does up to 75% of the steering for you. New design makes parking even easier.

4-Way Power Front Seat moves up, down, forward or back automatically. Do your own custom fitting at the touch of a button.

Wishing makes it so . . . with Ford Power Assists

At least that's the way you'll feel with power to help you steer, stop, adjust the seat and raise and lower windows!

Now you can have all of these fine-car luxuries at the low Ford price. And you can rule the weather, too, with Ford's PolarAire or SelectAire Conditioners—both include tinted glass for all windows; are available in any model equipped with V-8 engine. Fun's automatic in the '58 Ford.

SAFETY

1. Proven Lifeguard door locks give added protection against doors springing open upon impact, resist pulling forces up to 2,600 lb. 2. Lifeguard deep-center steering wheel protects driver from the steering post. 3. Lifeguard safety-swivel rearview mirror swings away if struck. 4. New double-anchored Lifeguard sun visors are full-cushioned with super shock-absorbing material.* 5. Lifeguard cushioning is also available for instrument panel.* Control knobs are deeply recessed for still more safety. 6. Safety belts keep you in your seat in case of impact.*

**worthwhile protection—at very modest extra cost*

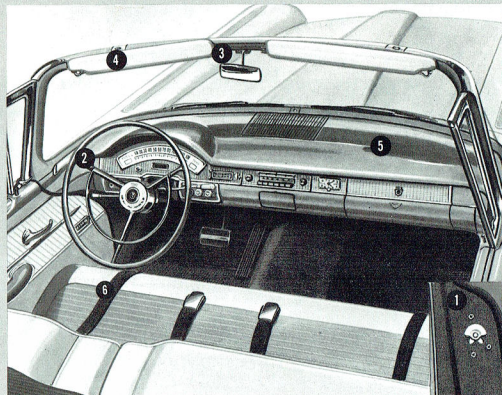

FAIRLANE *Town Sedan*

You step up to the fine-car class when you step into this handsome 4-door sedan . . . yet you pay no more than traditionally low Ford prices. It has the graceful look of a trim Victoria because the slim, steel center posts are smartly concealed behind the bright-metal window frames. And see how you can practically "customize" your Fairlane with matching Style Tone color combinations, Gunsight fender ornaments and chrome headlight trim package *or* the complete Country Club Trim option, including your choice of color-keyed Vinyl-Tex floor covering (standard) or Luxury Loom carpets (optional). The classic "flutes" in the steel roof add a crowning touch of advanced design.

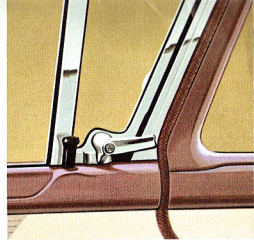
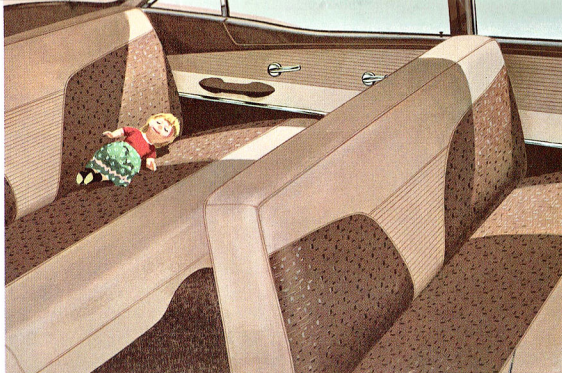

Inside door lock button is up front and close at hand for easier locking and unlocking. Triangle vent window tailored to the dashing slant of the Swept-Back front pillar, has positive-action latch at bottom.

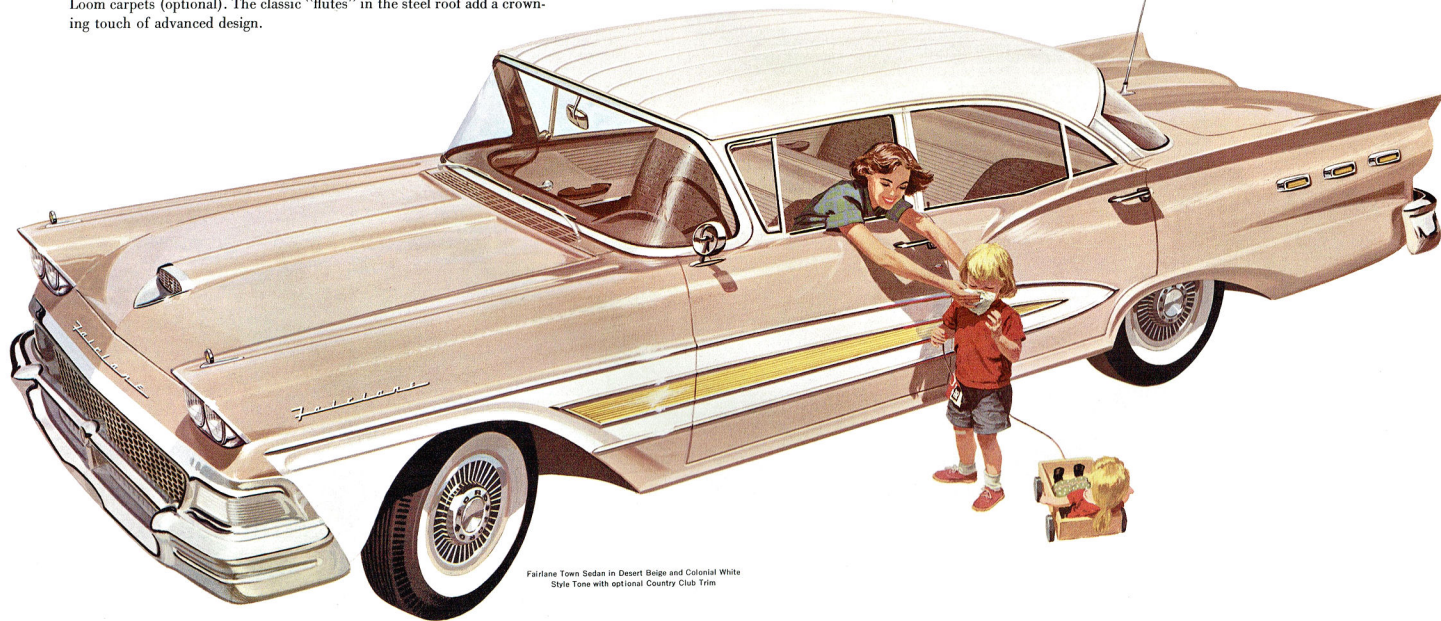

Fairlane Town Sedan in Desert Beige and Colonial White
Style Tone with optional Country Club Trim

GENUINE FORD ACCESSORIES FOR 1958

Rear Seat Speaker has extra sound quality that will remind you of high fidelity. Even when riding in noisy traffic, rear seat passengers hear radio programs clearly.

Aquomatic Windshield Washer-Wiper sprays two jets of water each time you press washer foot-pedal. Wipers go into action automatically. Release pedal and wipers automatically stop.

Deluxe Rear Deck Antenna adds to your Ford's distinctive appearance. Streamlined and plastic-trimmed, it is engineered for excellent reception.

Adjust-O-Ring Mirror gives you a wide range of adjustment. Its clear-view mirror and ring visor provide protection against rain, snow and mud.

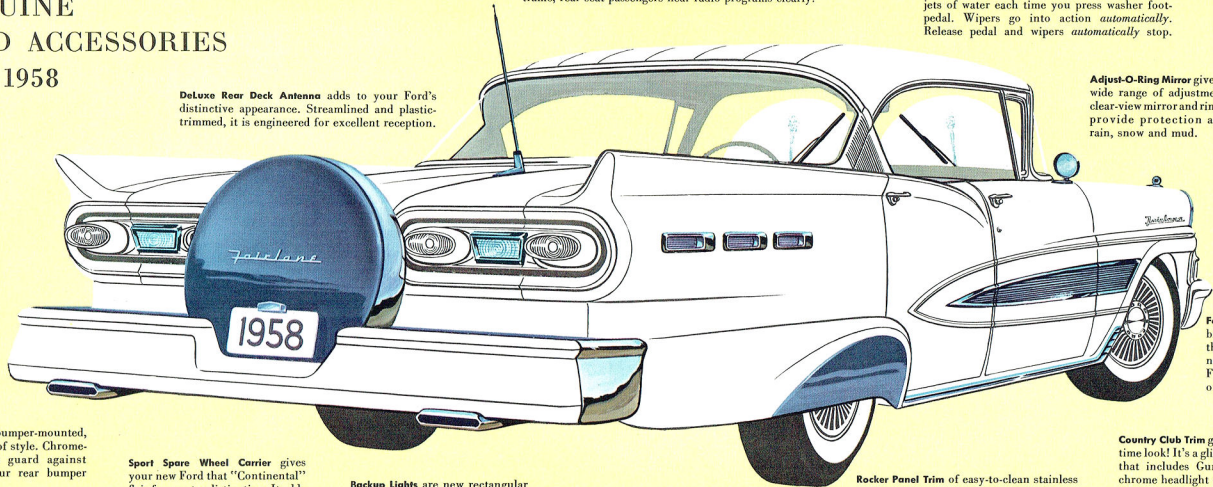

Gunsight Front Fender Ornaments and Chrome Headlight Trim give your car that "dressed up" look. They symbolize the ultra-smart styling that the whole world loved.

Fashion-Ray Wheel Covers of bright-metal add so much to the good appearance of your new Ford. They're standard on Fairlane 500 models; optional on Fairlans.

Exhaust Deflectors, bumper-mounted, give a bright note of style. Chrome-plated, they help guard against gases clouding your rear bumper and paint.

Sport Spare Wheel Carrier gives your new Ford that "Continental" flair for greater distinction. It adds about 10 inches to your car's length, and leaves more luggage space inside the trunk.

Backup Lights are new rectangular shape and built right into the car. They flood the area behind the car with twin beams of light when car is in reverse.

Fender Shields will help your 58 Ford to look longer, lower and livelier than ever. Made of steel, they can be painted to match your car's finish.

Rocker Panel Trim of easy-to-clean stainless steel makes your Ford look even longer and lower. And it protects the lower body edge against stone nicks.

Country Club Trim gives your car a fresh, spring-time look! It's a glittering package of glamour that includes Gunsight fender ornaments, chrome headlight trim, ribbed gold anodized aluminum side molding and rear fender ports. Available on Fairlane models only.

OTHER FINE FORD ACCESSORIES AT YOUR FORD DEALER'S

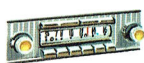

Signal-Seek Radio* automatically tunes in station in either direction of the dial. Town button (T) tunes local stations, Country button (C) gives broad coverage. *Transistor-Powered



Console Range Radio is transistor-powered for '58, yet is still moderately priced. Automatic push-button tuning gives you a choice of any five pre-selected stations you wish.

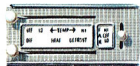

MagicAir System brings you heating, ventilating and defrosting all in one! Four big defroster nozzles give even heat distribution, effective windshield defrosting.



Self-Regulating Electric Clock retimes itself automatically each time you set it! Has illuminated dial. Optional on Fairlane models; standard equipment on Fairlane 500's.



PolarAir Conditioner offers you cool, cool comfort at surprisingly low cost. Its "on-off" magnetic clutch controls car temperature automatically (on V-8's only).

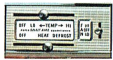

SelectAir Conditioner features larger compressor and new strategic placement of air registers. You get refrigerated cooling, ventilating, heating, and defrosting in one compact unit (on V-8's only).



Visored Full-View Mirror lets you drive more safely under all kinds of driving conditions. The new rearview mirror has ball joint for wide adjustment.



Inside Non-Clare Mirror turns off blinding glare from headlights behind you with a flick of your finger. Just press tab and glare is deflected away.



Visored Spotlight Mirror gives night-and-day convenience. And the hooded feature makes each effective in all weather. Adjusts easily from inside the car.



Chrome Headlight Trim is the newest of the new! Its glitter smartly accents the classic lines of the 58 Ford's dual headlights. Also available in an attractively-priced package with the Gunsight front fender ornaments!

ANTENNA, FENDER-MOUNTED * CAR MATS, CONTOUR, FRONT OR REAR

CAR MAT, TWIN CONTOUR, FRONT ONLY (ONE PIECE)

EXHAUST DEFLECTORS (DELTA WING) * FORD SEAT BELTS

FULL-VIEW MIRROR * HEATER, RECIRCULATING AND DEFROSTER

LIFEGUARD JR. REAR DOOR LOCKS * LOCKING GAS CAP

SEAT COVERS * TISSUE DISPENSER * VENTILATED SEAT CUSHIONS

FAIRLANE *Club Sedan*

You'll love the lively life you'll lead in this sleek 2-door sedan with "hardtop" styling. Makes you proud just to have it parked in front of the house. And of course it's at home *anywhere*, as a fine car should be. It loves road work. Sits on the freeways rock-steady. Takes to winding back roads like a duck takes to water. Sails over bumps as if the world didn't exist. It's over 17 solid feet of magnificent motorcar that looks, drives and rides like a million, yet its cost is smack in the low-price field.

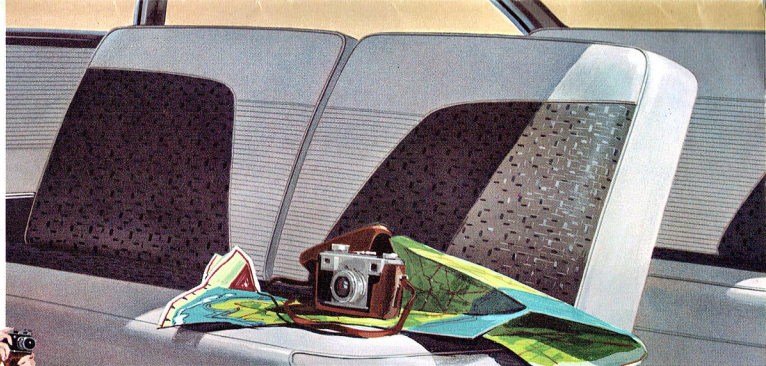

Pop! Up goes the counterbalanced deck lid, and there lies a regular cavern waiting for your luggage. Whether you're packing for a day at the beach or a month in the country, you can keep the seats reserved for passengers only.



Fairlane Club Sedan in Style Tone colors and standard molding

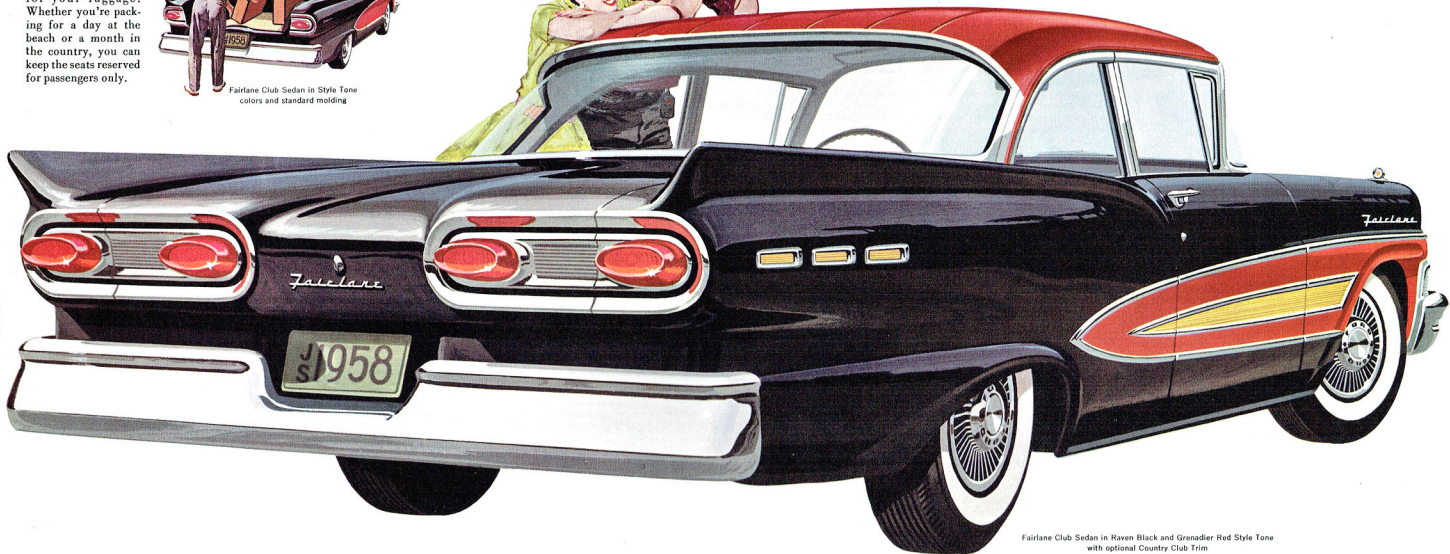

Fairlane Club Sedan in Raven Black and Grenadier Red Style Tone with optional Country Club Trim

FEATURE FACTS . . .

Exteriors: Gleaming, durable, baked-on body enamel in exciting new colors are available. 11 colors may be selected in Single Color exteriors, 13 in stunning new Style Tone combinations (also in conventional Two Tone combinations on Fairlane 500).

The basic colors are: Azure Blue, Silverstone Blue, Silverstone Green, Seaspray Green, Palomino Tan, Raven Black, Grenadier Red, Ball Bronze, Desert Beige, Gunmetal Gray, Sun Gold, Gulfstream Blue or Colonial White.

Fairlane exteriors come with a choice of standard bright-metal side molding or in optional Country Club Trim consisting of bright-metal side molding highlighted by a centered ribbed gold anodized aluminum molding and three bright-metal ports on rear fenders. Included are chrome headlight trim and Sunlight front fender ornaments (also optional as separate package on Fairlane and Fairlane 500).

Interiors: A rich variety of woven, textured nylon fabrics and leather-grained vinyl provide choices of truly luxurious upholstery selections in exclusive Random-Block, Damask, Shadow-Block and Royal Scot Tweed patterns. Floor covering in Fairlane models and the Sunliner is color-keyed Vinyl-Tex, which looks like carpeting, wears like vinyl. Other Fairlane 500 models have color-coordinated deep-loop Luxury-Loom carpets (also optional in Fairlane models).

See the complete array of colors and fabric selections at your Ford Dealer's.

Engines: 145-hp Mileage Maker Six—223-cu. in. displacement; 3.62" bore x 3.60" stroke; 8.6 to 1 compression ratio; regular fuel; manual choke. (For all models except Skyliner.)

205-hp Ford 292 V-8 (optional all models)—292-cu. in. displacement; 3.75" bore x 3.30" stroke; 9.1 to 1 compression ratio; regular fuel. Low-silhouette 2-venturi carburetor, automatic choke, Y-type single exhaust (dual exhausts on Skyliner and Sunliner).

New 240-hp Interceptor 332 V-8 (optional for Fairlane 500 models)—332-cu. in. displacement; 4.00" bore x 3.30" stroke; 9.5 to 1 compression ratio; regular fuel. Low-silhouette 2-venturi carburetor, automatic choke, Y-type single exhaust (dual exhausts on Skyliner and Sunliner).

New 265-hp Interceptor 332 Special V-8 (optional for Fairlane 500 models)—332-cu. in. displacement; 4.00" bore x 3.30" stroke; 9.5 to 1 compression ratio; regular fuel. Low-silhouette 4-venturi carburetor, automatic choke, Y-type single exhaust (dual exhausts on Skyliner and Sunliner).

New 300-hp Interceptor 352 Special V-8 (optional all models)—352-cu. in. displacement; 4.00" bore x 3.50" stroke; 10.2 to 1 compression ratio; premium fuel. Low-silhouette 4-venturi carburetor, automatic choke, dual exhausts.

Engine Features: For greater economy and longer life, all Ford engines have Short Stroke, low-friction design, with Deep-Block construction; intake and exhaust valves are free-turning, overhead type; super-filter air cleaner has reusable paper element; lubrication is full-pressure type with Full-Flow disposable-type oil filter; 12-volt electrical system gives better starting ability; turboaction 18-mm. spark plugs are designed for increased gas mileage; V-8 engines are electronically balanced while operating under own power, to provide optimum smoothness. All Interceptor V-8's feature self-adjusting, hydraulic valve lifters for quietness and Precision Fuel Induction for superior performance and economy.

Fordomatic Drive: Features smooth-acting torque converter combined with automatic gear train. Three forward gears, one reverse. Water-cooled with V-8's, air-cooled with Six. For convenience, all 3 forward gears are available with selector lever in drive "D" position.

Cruise-O-Matic Drive: A brand-new automatic transmission with all the advantages of Fordomatic plus an additional Drive selection which permits low-gear starts in "D1" range for full-power getaways and intermediate-gear starts in "D2" range for sure-footed acceleration, coupled with a 2.69 to 1 rear axle ratio for fuel economy. With Interceptor Special V-8's only.

Wide-Contoured Frame: Strong, stiff, box-section frame. Skyliner and Sunliner have 4 cross members plus X-member, others have 5 cross members. Side rails extend outside passenger area, for better foot room and increased side protection. Silent-Grip body mounting system.

Suspension: 4-Way Swept-Back ball-joint front suspension has new, threaded, permanently lubricated bushings in upper control arms for softer, easier ride. Rubber-bushed ride stabilizer controls roll on turns. Eyes-Road rear springs provide softer action, variable rate with tension-type shackles and wind-up control rubber bumpers over springs. Viscous-control shock absorbers front and rear, give optimum ride control.

Ford-Aire Suspension: Provides the utmost in smooth, soft-riding characteristics regardless of load or road conditions. Engine-driven compressor furnishes air to reservoir tank which feeds to individual nylon-rubber "pillows" at each wheel. Automatic leveling valves regulate air pressure to maintain constant car height regardless of weight or load position. Optional with Interceptor V-8's and automatic transmissions.

Rear Axle: Husky, low-slung hypoid, semi-floating, with special Deep-Offset straddle-mounted pinion, permits lower car level without sacrifice of inside room.

Torque-Tailored Axle Ratios (to 1): Skyliner: Conventional Drive—3.56 with 292 V-8 or 352 Special V-8. Overdrive

—3.70 with 292 V-8, 3.56 with 352 Special V-8. Fordomatic Drive—2.91 with 332 V-8 or 352 Special V-8. Cruise-O-Matic Drive—2.69 with Special V-8's. Other models: Conventional Drive—3.56 with Six, 292 V-8 or 352 Special V-8. Overdrive—3.70 with Six or 292 V-8, 3.56 with 352 Special V-8. Fordomatic Drive—3.56 with Six, 3.10 with 292 V-8 in Fairlane and 2.91 with 332 V-8 in Fairlane 500, 2.91 with 352 Special V-8. Cruise-O-Matic Drive—2.69 with 352 Special V-8 in Fairlane, and with 332 V-8 or 352 Special V-8 in Fairlane 500.

Steering: New Magic-Circle recirculating-ball type steering gear provides low friction, easier steering, 27 to 1 overall steering ratio, 17½", 3-spoke, deep-dish Lifeguard steering wheel. Approximately 40-foot turning diameter.

Brakes: Giant-Grip double-sealed self-energizing hydraulic brakes have suspended pedal, dash-mounted master cylinder. Drum diameter is 11". Lining area is 180 sq. in. (191 sq. in. on Skyliner). Optional Swift Sure power brakes have special low pedal and power reservoir tank.

Tires: 4-ply black tubeless on safety-type rims, standard on all models. Skyliner—8.00 x 14 on 5½" rims. Sunliner with V-8 and automatic transmission—8.00 x 14 on 5" rims. All others—7.50 x 14 on 5" rims.

Dimensions: 118" wheelbase; 59.0" front, 56.4" rear tracks. Over-all length, 207.0" (Skyliner 211.0"). Height (maximum with design load), 56.2" for Victorias and Sedans, 56.5" for Sunliner, 56.3" for Skyliner. Maximum over-all width, 78".

Other Available Equipment: Lifeguard padded instrument panel and cushioned sun visors, Ford seat belts. Manually operated 4-way front seat, 4-Way Power front seat, Swift Sure power brakes, Master-Guide power steering, Power-Lift windows, 1-Rest tinted safety glass. Overdrive, Fordomatic, Cruise-O-Matic, Air Conditioners: Selectaire or Polaraire, including tinted glass (V-8's only). White sidewall tires. Special fuel and vacuum pump unit for positive-action windshield wipers.

Prices: All Power Assists and Accessories as well as some of the items illustrated or referred to in this catalog are at extra cost. For the price of the model with the equipment you desire, see your Ford Dealer.

Comparative information in this catalog was obtained from authoritative sources, but is not guaranteed. The specifications contained herein were in effect at the time this catalog was approved for printing. Ford Division of Ford Motor Company reserves the right to discontinue models at any time, or change specifications or design, without notice and without incurring obligation.

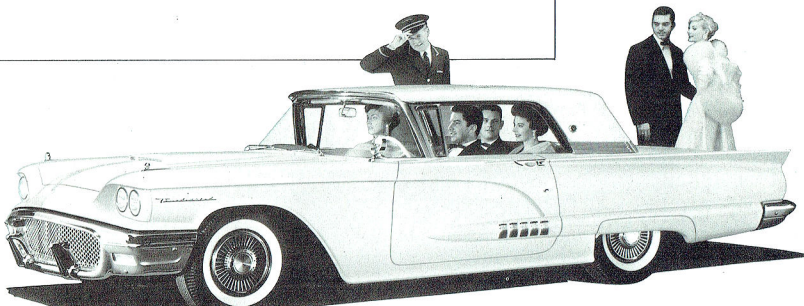

Set your family 2-FORD FREE

Here, you see the other glamorous new Fords for '58—headed by the fabulous new 4-passenger Thunderbird! You can team up almost any one of these beauties with a new Fairlane or Fairlane 500 and still pay no more than you would pay for *one* expensive car! But what a difference in family freedom! Pick out the best two-Ford combination for *your* family now. They're all priced Ford-low!

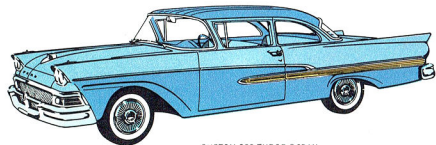

CUSTOM 300 TUDOR SEDAN

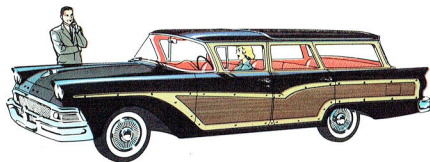

9-PASSENGER COUNTRY SQUIRE

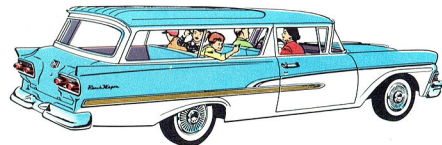

DEL RIO RANCH WAGON

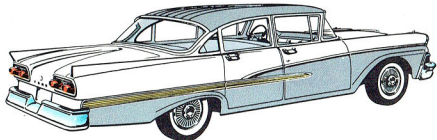

CUSTOM 300 FORDOR SEDAN

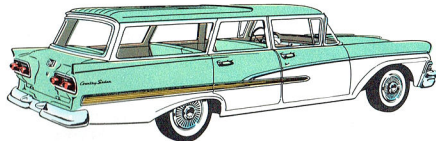

9-PASSENGER COUNTRY SEDAN

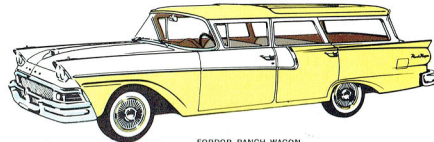

FORDOR RANCH WAGON

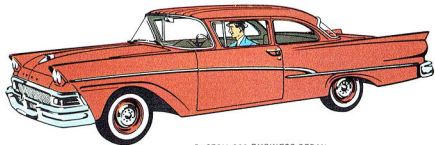

CUSTOM 300 BUSINESS SEDAN



6-PASSENGER COUNTRY SEDAN

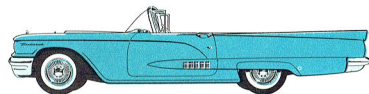

4-PASSENGER THUNDERBIRD CONVERTIBLE

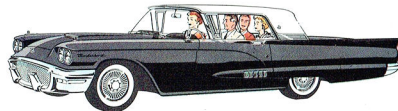

4-PASSENGER THUNDERBIRD HARDTOP

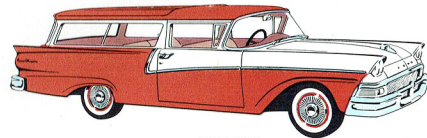

RANCH WAGON

There's nothing newer in the world!



Proved and
approved around
the world

