

SIERRA HD MODELS

2024 FEATURES, SPECS AND OPTIONS



We have tried to make this guide comprehensive and factual. We reserve the right, however, to make changes at any time, without notice, in prices, colors, materials, equipment, specifications, models and availability. Specifications, dimensions, measurements, ratings and other numbers in this guide and other printed materials provided at the dealership or affixed to vehicles are approximations based on design and engineering drawings, prototypes and laboratory tests. Your vehicle may differ due to variations in manufacture and equipment. Since some information may have been updated since the time of publication, please check with your GMC dealer for complete details.

GMC
WE ARE PROFESSIONAL GRADE

TABLE OF CONTENTS

03. MODEL OVERVIEW HIGHLIGHTS

Sierra HD Pro
Sierra HD SLE
Sierra HD SLT

04. MODEL OVERVIEW HIGHLIGHTS

Sierra HD AT4
Sierra HD AT4X

05. MODEL OVERVIEW HIGHLIGHTS

Sierra HD Denali
Sierra HD Denali Ultimate

06-10. KEY FEATURES

Exterior
Interior
Capability
Safety and technology

11-12. MODEL PACKAGES

Select packages available

13. CAB AND BED CONFIGURATIONS

Regular Cab long bed
Double Cab long bed
Double Cab standard bed
Crew Cab standard bed
Crew Cab long bed

14-16. MODEL SPECS

Sierra HD 2500 Regular Cab
Sierra HD 3500 Regular Cab
Sierra HD 2500 Double Cab
Sierra HD 3500 Double Cab
Sierra HD 2500 Crew Cab
Sierra HD 3500 Crew Cab

17. TRAILERING OVERVIEW

Key trailering features
Key specifications
Powertrain

18-21. PAYLOAD AND TRAILERING SPECS

Sierra HD 2500
Sierra HD 3500 SRW
Sierra HD 3500 DRW

22. POWERTRAIN SPECS

Engine specifications
Transmission specifications

23-30. TRAILERING TECHNOLOGY

ProGrade™ Trailering System
In-vehicle Trailering App
myGMC Mobile App
Smart trailer integration
Camera system
Camera-view compatibility
Calibration tips
Trailering technology availability

31. TRAILERING TERMINOLOGY

Curb weight
Gross Vehicle Weight (GVW)
Gross Vehicle Weight Rating (GVWR)
Gross Combined Weight (GCW)
Gross Combined Weight Rating (GCWR)
Cargo weight
Max payload
Gross Axle Weight (GAW)
Gross Axle Weight Rating (GAWR)
Gross trailer weight
Tongue (or hitch) weight

32. HITCH STYLES

Weight-carrying hitch
Weight-distributing hitch
Fifth-wheel hitch
Gooseneck hitch

33. TRAILER STYLES

Conventional trailer
Fifth-wheel trailer
Gooseneck trailer

34. TRAILERING LABEL

How to read a trailering label

35. ACCESSORIES

Key available accessories



SIERRA HD PRO KEY FEATURES

- | 6.6L V8 gas engine with Allison® 10-speed automatic transmission
- | LED headlamps and daytime running lamps
- | Trailing package and trailing mirrors
- | Wireless Apple CarPlay® compatibility¹
- | Wireless Android Auto™ compatibility²
- | Available World's First Six-Function GMC MultiPro™ Tailgate



SIERRA HD SLE KEY FEATURES

- | 6.6L V8 gas engine with Allison 10-speed automatic transmission
- | 13.4" diagonal center touch-screen and 12.3" diagonal Driver Information Center
- | Available X31 Off-Road Package with twin-tube Rancho® shocks and skid plates
- | Wireless Apple CarPlay® compatibility¹
- | Wireless Android Auto™ compatibility²
- | World's First Six-Function GMC MultiPro Tailgate



SIERRA HD SLT KEY FEATURES

- | 6.6L V8 gas engine with Allison 10-speed automatic transmission
- | 13.4" diagonal center touch-screen and 12.3" diagonal Driver Information Center
- | Dual-zone automatic climate control
- | Available 10-way power-adjustable front heated and ventilated bucket seats with perforated leather appointments
- | World's First Six-Function GMC MultiPro Tailgate

AVAILABLE COLORS



ONYX
BLACK³



SUMMIT
WHITE



DOWNPOUR
METALLIC^{3,4}



STERLING
METALLIC³



REDWOOD
METALLIC^{3,5}



THUNDERSTORM
GRAY^{3,6}



VOLCANIC RED
TINTCOAT^{3,7}



CARDINAL
RED^{3,8}



WHITE FROST
TRICOAT^{3,9}



TITANIUM RUSH
METALLIC^{3,10}

¹Vehicle user interface is a product of Apple® and its terms and privacy statements apply. Requires compatible iPhone® and data plan rates apply. Apple CarPlay is a trademark of Apple, Inc. Siri, iPhone and iTunes are trademarks of Apple, Inc., registered in the U.S. and other countries. ²Vehicle user interface is a product of Google, and its terms and privacy statements apply. Wireless use of Android Auto requires a compatible Android 11.0+ phone and compatible active data plan. Check g.co/androidauto/requirements for compatibility. Android and Android Auto are trademarks of Google LLC. ³Extra-cost color. ⁴Not available on AT4 or AT4X. ⁵Not available on Pro, AT4, AT4X or Denali. ⁶Not available on Denali or Denali Ultimate. ⁷Not available on Pro or Denali Ultimate. ⁸Not available on AT4, AT4X, Denali or Denali Ultimate. ⁹Not available on Pro, SLE, AT4 or AT4X. ¹⁰Not available on Pro.



SIERRA 2500 HD AT4 KEY FEATURES

- | Unique Jet Black interior with Kalahari accents and heated and ventilated perforated front leather seating surfaces
- | Redesigned AT4 grille, front fascia and bumper
- | New LED dual-projector headlamps and signature lighting with animated sequences
- | Off-road suspension with Rancho shocks and skid plates
- | 2-speed AutoTrac transfer case with active automatic 4WD
- | Traction Select System with off-road and Tow/Haul modes
- | 20" gloss-black aluminum wheels with available BFGoodrich® off-road tires
- | Available 6.6L Duramax Turbo Diesel V8 engine with Allison 10-speed automatic transmission



SIERRA 2500 HD AT4X KEY FEATURES

- | Standard 6.6L V8 gas engine with Allison 10-speed automatic transmission
- | Factory-installed 1.5" suspension lift
- | Multimatic™ DSSV dampers
- | Rear e-locking differential
- | 35" Goodyear® Territory MT tires
- | Exclusive Obsidian Rush interior with full-grain leather seating
- | Available AEV Edition
- | Heated and ventilated 16-way power front seats with massage feature
- | Large steel transfer case skid plate and front aluminum skid plate

AVAILABLE COLORS



ONYX
BLACK¹



SUMMIT
WHITE



DOWNPOUR
METALLIC^{1,2}



STERLING
METALLIC¹



REDWOOD
METALLIC^{1,3}



THUNDERSTORM
GRAY^{1,4}



VOLCANIC RED
TINTCOAT^{1,5}



CARDINAL
RED^{1,6}



WHITE FROST
TRICOAT^{1,7}



TITANIUM RUSH
METALLIC^{1,8}

¹Extra-cost color. ²Not available on AT4 or AT4X. ³Not available on Pro, AT4, AT4X or Denali. ⁴Not available on Denali or Denali Ultimate. ⁵Not available on Pro or Denali Ultimate. ⁶Not available on AT4, AT4X, Denali or Denali Ultimate. ⁷Not available on Pro, SLE, AT4 or AT4X. ⁸Not available on Pro.



SIERRA 2500 HD DENALI KEY FEATURES

- | 6.6L V8 gas engine with Allison 10-speed automatic transmission
- | Available 6.6L Duramax Turbo Diesel V8 engine with Allison 10-speed automatic transmission
- | Bold, new front bumper, fascia and redesigned Denali chrome grille
- | 20" ultra-bright machined wheels with bright chrome inserts (single-rear-wheel models only)
- | 13.4" diagonal center touch-screen, 12.3" diagonal digital Driver Information Center and available multicolor 15" diagonal Head-Up Display
- | Denali-exclusive authentic open-pore wood, patterned aluminum trim and Forge perforated leather seating surfaces
- | Up to 14 available camera views¹ including enhanced transparent trailer view



SIERRA HD DENALI ULTIMATE KEY FEATURES

- | 6.6L Duramax Turbo Diesel V8 engine with Allison 10-speed automatic transmission
- | Signature Denali Ultimate Vader chrome grille and unique Denali Ultimate fender badging
- | Exclusive 20" ultra-bright machined aluminum wheels with gloss-black inserts (single-rear-wheel models only)
- | Ultimate Alpine Umber interior featuring full-grain leather seating and authentic open-pore Paldao wood
- | Power sunroof
- | 16-way power front seats with massage feature
- | 12-speaker Bose² Premium Series with Centerpoint[®] surround sound
- | Illuminated power assist steps and MultiPro Audio System by KICKER^{®3}

AVAILABLE COLORS



ONYX
BLACK⁴



SUMMIT
WHITE



DOWNPOUR
METALLIC^{4,5}



STERLING
METALLIC⁴



REDWOOD
METALLIC^{4,6}



THUNDERSTORM
GRAY^{4,7}



VOLCANIC RED
TINTCOAT^{4,8}



CARDINAL
RED^{4,9}



WHITE FROST
TRICOAT^{4,10}



TITANIUM RUSH
METALLIC^{4,11}

YOUR SIERRA HD AWAITS

KEY FEATURES

See your GMC dealer or gmc.com for more feature details and requirements.

EXTERIOR

Vertical trailering mirrors (see gmc.com or your dealer for more feature details)

World's First Six-Function GMC MultiPro Tailgate

MultiPro Audio System by KICKER^{®1} (accessory)

Spray-on bedliner

12 cargo bed tie-downs

Front recovery hooks²

Side bed steps

CornerStep rear bumper

LED dual-projector headlamps with fade-on/fade-off animation

LED fog lamps

LED roof marker lamps (standard on all 3500 HD Dual Rear Wheel (DRW) models)

LED wheel arch lamps

Power-retractable assist steps with LED perimeter lighting

PRO

SLE

SLT

AT4

AT4X

DENALI

DENALI
ULTIMATE

● Standard ○ Available - Not Available

YOUR SIERRA HD AWAITS

KEY FEATURES

See your GMC dealer or gmc.com for more feature details and requirements.

INTERIOR

Dual-zone automatic climate control

40/20/40 front bench seat

10-way power driver seat adjuster including lumbar

12-way power driver and front-passenger seat adjuster, including lumbar

16-way power driver and front-passenger seat adjuster, including lumbar and massage

Heated and ventilated front bucket seats

Heated second-row outboard seats

Heated wrapped steering wheel

Rear air vents (Double Cab and Crew Cab models)

Rear seatback storage

Premium floor liners with removable carpet inserts

	PRO	SLE	SLT	AT4	AT4X	DENALI	DENALI ULTIMATE
Dual-zone automatic climate control	-	○	●	●	●	●	●
40/20/40 front bench seat	●	●	●	-	-	-	-
10-way power driver seat adjuster including lumbar	-	○	●	●	-	-	-
12-way power driver and front-passenger seat adjuster, including lumbar	-	-	-	-	-	●	-
16-way power driver and front-passenger seat adjuster, including lumbar and massage	-	-	-	-	●	-	●
Heated and ventilated front bucket seats	-	-	○	●	●	●	●
Heated second-row outboard seats	-	-	○	●	●	●	●
Heated wrapped steering wheel	-	○	●	●	●	●	●
Rear air vents (Double Cab and Crew Cab models)	●	●	●	●	●	●	●
Rear seatback storage	-	○	●	●	●	●	●
Premium floor liners with removable carpet inserts	-	○	○	●	●	○	○

● Standard ○ Available — Not Available

YOUR SIERRA HD AWAITS

KEY FEATURES

See your GMC dealer or gmc.com for more feature details and requirements.

CAPABILITY

6.6L gasoline V8 engine with direct injection

6.6L Duramax Turbo Diesel V8 engine

Allison 10-speed automatic transmission

Factory-installed 1.5" suspension lift

Multimatic DSSV dampers

BFGoodrich off-road T/A KO3 tires

35" Goodyear Territory MT tires

Traction Select System with Tow/Haul mode

Digital variable steering assist

Duralife brake rotors

Automatic-locking rear differential

Rear e-locking differential

AutoTrac transfer case (2-speed active)

PRO

SLE

SLT

AT4

AT4X

DENALI

DENALI
ULTIMATE



● Standard ○ Available — Not Available

YOUR SIERRA HD AWAITS

KEY FEATURES

See your GMC dealer or gmc.com for more feature details and requirements.

SAFETY AND TECHNOLOGY

Sierra Heavy Duty Pro Safety¹ (includes Forward Collision Alert, Following Distance Indicator, Front Pedestrian Braking, IntelliBeam, Lane Departure Warning and Automatic Emergency Braking)

Trailer Side Blind Zone Alert¹

Adaptive Cruise Control with trailering¹

High Definition Surround Vision¹

Multicolor 15" diagonal Head-Up Display

13.4" diagonal Premium GMC Infotainment System²

12.3" diagonal digital Driver Information Center

Google built-in³ (3-year GMC Connected Vehicle⁴ subscription is included on Denali and Denali Ultimate)

Wireless charging⁵

	PRO	SLE	SLT	AT4	AT4X	DENALI	DENALI ULTIMATE
Sierra Heavy Duty Pro Safety ¹ (includes Forward Collision Alert, Following Distance Indicator, Front Pedestrian Braking, IntelliBeam, Lane Departure Warning and Automatic Emergency Braking)	●	●	●	●	●	●	●
Trailer Side Blind Zone Alert ¹	—	○	○	●	●	●	●
Adaptive Cruise Control with trailering ¹	○	○	○	○	●	○	●
High Definition Surround Vision ¹	—	○	○	●	●	●	●
Multicolor 15" diagonal Head-Up Display	—	—	—	○	●	○	●
13.4" diagonal Premium GMC Infotainment System ²	—	●	●	●	●	●	●
12.3" diagonal digital Driver Information Center	—	●	●	●	●	●	●
Google built-in ³ (3-year GMC Connected Vehicle ⁴ subscription is included on Denali and Denali Ultimate)	—	○	○	○	○	●	●
Wireless charging ⁵	—	—	○	●	●	●	●

● Standard ○ Available — Not Available

CONTINUED

¹Safety or driver-assistance features are no substitute for the driver's responsibility to operate the vehicle in a safe manner. Read the vehicle Owner's Manual for important feature limitations and information. ²Functionality varies by model. Full functionality requires compatible Bluetooth® and smartphone, and USB connectivity for some devices. ³Google built-in services are subject to limitations, and availability may vary by vehicle, infotainment system and location. Select service plan required. Certain Google actions and functionality may require account linking. User terms and privacy statements apply. Google, Google Play and Google Maps are trademarks of Google LLC. ⁴Requires properly equipped 2024 Sierra vehicle. Includes 3-year trial of Connected Vehicle from time of online enrollment by dealer. Services subject to acceptance of terms and limitations. Data plans offered by AT&T®. Certain services require working electrical system, cell reception and GPS signal. Offer transferable. Offer subject to change. See onstar.com for details. Availability subject to change. ⁵The system wirelessly charges one compatible mobile device. Some phones have built-in wireless charging technology and others require a special adapter/back cover. To check for phone or other device compatibility, see gmc.com/support/vehicle/phone-connect or consult your carrier.

YOUR SIERRA HD AWAITS

KEY FEATURES

See your GMC dealer or gmc.com for more feature details and requirements.

SAFETY AND TECHNOLOGY CONTINUED

Bose¹ audio system with Richbass woofer

Bose¹ 12-speaker Premium Series with Centerpoint surround sound

ProGrade Trailering System with in-vehicle Trailering App²

Wireless Apple CarPlay³ compatibility³

Wireless Android Auto compatibility⁴

SiriusXM[®] with 360L 3-month trial subscription⁵

	PRO	SLE	SLT	AT4	AT4X	DENALI	DENALI ULTIMATE
Bose ¹ audio system with Richbass woofer	-	-	○	●	-	●	-
Bose ¹ 12-speaker Premium Series with Centerpoint surround sound	-	-	-	-	●	-	●
ProGrade Trailering System with in-vehicle Trailering App ²	-	○	●	●	●	●	●
Wireless Apple CarPlay ³ compatibility ³	●	●	●	●	●	●	●
Wireless Android Auto compatibility ⁴	●	●	●	●	●	●	●
SiriusXM [®] with 360L 3-month trial subscription ⁵	-	●	●	●	●	●	●

● Standard ○ Available - Not Available



¹Bose is a registered trademark of the Bose Corporation in the U.S. and other countries. ²App functionality and features vary with vehicle equipment and trim level. Data connection may be required. Some features require active service plan and working electrical system. Terms and limitations apply. ³Vehicle user interface is a product of Apple[®] and its terms and privacy statements apply. Requires compatible iPhone[®] and data plan rates apply. Apple CarPlay is a trademark of Apple, Inc. Siri, iPhone and iTunes are trademarks of Apple, Inc., registered in the U.S. and other countries. ⁴Vehicle user interface is a product of Google, and its terms and privacy statements apply. Wireless use of Android Auto requires a compatible Android 11.0+ phone and compatible active data plan. Check g.co/androidauto/requirements for compatibility. Android and Android Auto are trademarks of Google LLC. ⁵If you decide to continue service after your trial, your selected subscription plan will automatically renew thereafter. You will be charged at then-current rates. Fees and taxes apply. To cancel, you must call SiriusXM at 1-866-635-2349. See SiriusXM Customer Agreement for complete terms at siriusxm.com. All fees and programming subject to change. ©2024 SiriusXM Radio, Inc. All rights reserved.

SELECT PACKAGES

See your GMC dealer or gmc.com for more feature details and requirements.

PRO

CONVENIENCE PACKAGE Includes EZ-Lift Tailgate (power-lock and -release), cruise control, tinted glass, LED cargo bed lighting, rear-window defogger and Double and Crew Cab models include outside power-adjustable vertical trailing mirrors with heated upper glass

1SA PRO SAFETY PLUS PACKAGE Includes Rear Park Assist,¹ Lane Change Alert with Side Blind Zone Alert,¹ Rear Cross Traffic Alert¹ and outside power-adjustable vertical trailing mirrors with heated and auto-dimming upper glass, lower convex mirrors, turn-signal indicators, puddle lamps, perimeter lighting, auxiliary lighting and power-folding/manual extension

SLE

SLE CONVENIENCE PACKAGE Includes 120-volt power outlet, 120-volt bed-mounted power outlet, dual climate control, 10-way power driver seat including power lumbar, manual tilt/telescoping steering column, LED fog lamps, roof marker lamps on single-rear-wheel (SRW) models and 2 charge-only USB ports²

SLE VALUE PACKAGE Includes SLE Convenience Package, Heated Package, Remote Start Package and spray-on bedliner (available on Crew Cab and Double Cab models)

SLE PREFERRED PACKAGE Includes Hitch Guidance with Hitch View,¹ Adaptive Cruise Control,¹ cargo bed lighting, in-vehicle Trailing App,³ Universal Home Remote (Crew Cab and Double Cab models), rear sliding power window (Crew Cab and Double Cab models) and cloth Rear-Seat Storage Package (Crew Cab models)

SLE REMOTE START PACKAGE Includes remote start, content theft alarm and rear-window defogger

HEATED PACKAGE Includes heated driver and front outboard passenger seats and heated steering wheel

SLT

SLT CONVENIENCE PACKAGE Includes bucket seats with center console, ventilated front seats, wireless charging,⁴ 2 USB ports² (inside console with bucket seats), Bose⁵ premium audio system with Richbass woofer; single-rear-wheel (SRW) models also include LED roof marker lamps

SLT PREFERRED PACKAGE Includes rear outboard heated seats, rear sliding power window, Universal Home Remote and Adaptive Cruise Control¹

SLT PREMIUM PACKAGE Includes SLT Convenience Package, SLT Preferred Package, Sierra Heavy Duty Pro Safety Plus Package,¹ 6" rectangular, cab-length chrome assist steps and spray-on bedliner

CONTINUED

¹Safety or driver-assistance features are no substitute for the driver's responsibility to operate the vehicle in a safe manner. Read the vehicle Owner's Manual for important feature limitations and information. ²Not compatible with all devices. ³App functionality and features vary with vehicle equipment and trim level. Data connection may be required. Some features require active service plan and working electrical system. Terms and limitations apply. ⁴The system wirelessly charges one compatible mobile device. Some phones have built-in wireless charging technology and others require a special adapter/back cover. To check for phone or other device compatibility, see gmc.com/support/vehicle/phone-connect or consult your carrier. ⁵Bose is a registered trademark of the Bose Corporation in the U.S. and other countries.

SELECT PACKAGES CONTINUED

See your GMC dealer or gmc.com for more feature details and requirements.

AT4

AT4 PREFERRED PACKAGE Includes Universal Home Remote, rear sliding power window, roof marker lamps and Adaptive Cruise Control¹

AT4 PREMIUM PLUS PACKAGE Includes AT4 Preferred Package, Technology Package, power sunroof and AT4 high-clearance steps

AT4X

AT4X AEV EDITION Includes front and rear AEV stamped-steel bumpers with heavy-duty cast recovery points, gloss-black door handles and black tailgate accent, 18" AEV Salta gloss-black aluminum wheels, 18" x 9" spare wheel, stamped-steel front approach skid plate, stamped-steel steering gear skid plate, stamped-steel transfer case skid plate, AEV-embroidered head restraints (front only) and AEV-branded floor liners

DENALI

DENALI RESERVE PACKAGE Includes Technology Package and power sunroof

ADDITIONAL PACKAGES

SIERRA HEAVY DUTY PRO SAFETY PLUS PACKAGE¹ Includes Rear Park Assist (SLE only), in-vehicle Trailing App² (SLE only), Front and Rear Park Assist (SLT only), Safety Alert Seat (SLT only), Trailer Side Blind Zone Alert and Rear Cross Traffic Alert; Crew Cab and Double Cab models include Bed View Camera, High Definition Surround Vision and Trailer Camera Provisions (available on SLE and SLT)

TECHNOLOGY PACKAGE Includes Rear Camera Mirror,¹ Adaptive Cruise Control¹ (Denali only) and multicolor 15" diagonal Head-Up Display (available on AT4 and Denali)

X31 OFF-ROAD AND PROTECTION PACKAGE Requires 4WD model. Includes off-road suspension with twin-tube Rancho shocks, Hill Descent Control, skid plates, spray-on bedliner, all-weather floor liners and X31 hard badge on bed, plus either 18" machined aluminum wheels with Dark Gray Metallic accents and all-terrain blackwall tires on SLE or 20" machined aluminum wheels with Bright Silver accents and all-terrain blackwall tires on SLT (available on SRW Double Cab SLE and Crew Cab SLE and SLT).

X31 OFF-ROAD PACKAGE Requires 4WD model. Includes off-road suspension with twin-tube Rancho shocks, all-terrain tires, Hill Descent Control, skid plates and X31 hard badge on bed. Not available with dual-rear-wheel (DRW) models (available on SRW Pro, SLE and SLT).

SNOW PLOW PREP/CAMPER PACKAGE Requires 4WD model. Includes 220-amp alternator, increased front GAWR, skid plates, pass-through dash grommet hole and roof emergency light provisions (available on all trims).

GOOSENECK/FIFTH-WHEEL PREP PACKAGE Includes hitch platform with tray to accept ball, stamped bed holes with removable caps installed, integrated trailer brake controller on Pro models and bed-mounted 7-pin trailer harness. Additional package content including a spray-on bedliner varies by trim. See your dealer or gmc.com for more details (available on all trims).

HEAVY-DUTY FRONT SPRING/CAMPER PACKAGE Includes increased front GAWR (available on Pro, SLE, SLT, AT4, Denali and Denali Ultimate)

2500 MAX TRAILERING PACKAGE Requires available 6.6L Duramax Turbo Diesel V8 engine. Includes 3500 HD frame, 3500 HD leaf springs, 3500 HD Shock Package, Gooseneck/Fifth-Wheel Prep Package with bed-stamped holes and caps (not included on Pro) and 12" rear axle (available on Regular Cab and Crew Cab Pro and SLE and Crew Cab SLT, AT4, Denali and Denali Ultimate)

3500 MAX TRAILERING PACKAGE Requires 2WD DRW model and available 6.6L Duramax Turbo Diesel V8 engine. Includes integrated trailer brake controller, Heavy-Duty Front Spring/Camper Package, 18" polished forged aluminum wheels and Gooseneck/Fifth-Wheel Prep Package with bed-stamped holes (available on Regular Cab Pro trim only).

¹Safety or driver-assistance features are no substitute for the driver's responsibility to operate the vehicle in a safe manner. Read the vehicle Owner's Manual for important feature limitations and information. ²App functionality and features vary with vehicle equipment and trim level. Data connection may be required. Some features require active service plan and working electrical system. Terms and limitations apply.

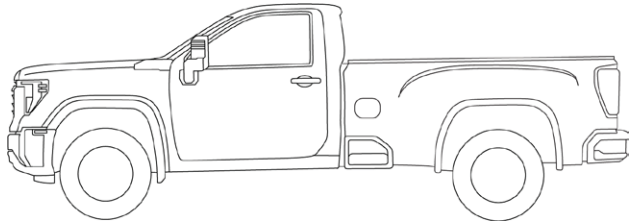

REGULAR CAB LONG BED

Available on Pro and SLE in single- or dual-rear-wheel configurations.

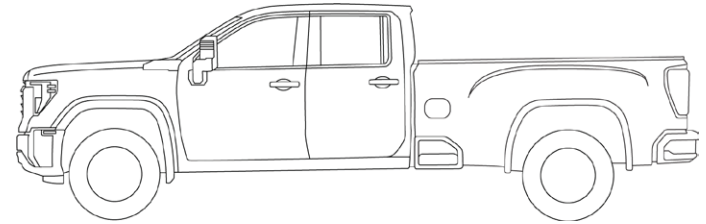

DOUBLE CAB LONG BED

Available on Pro and SLE in single- or dual-rear-wheel configurations.

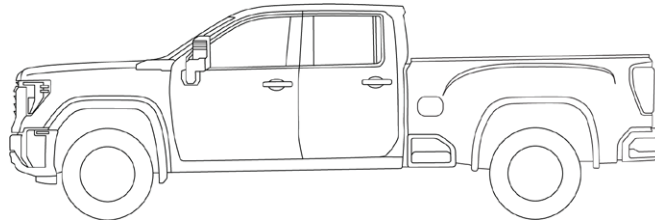

DOUBLE CAB STANDARD BED

Available on Pro and SLE in single-rear-wheel configurations.

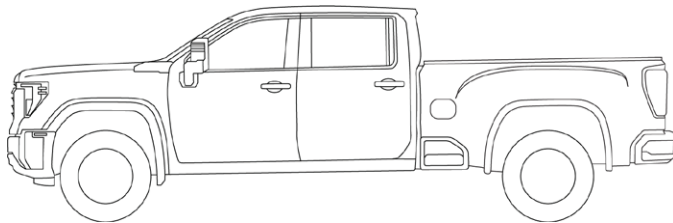

CREW CAB STANDARD BED

Available on Pro, SLE, SLT, AT4, 2500 AT4X, Denali and Denali Ultimate in single-rear-wheel configurations.

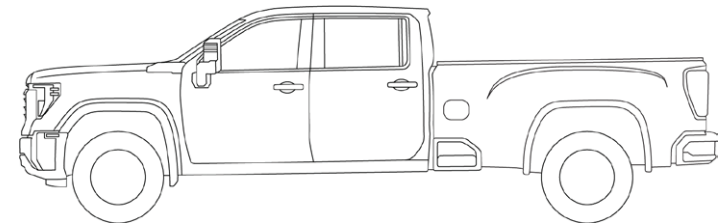

CREW CAB LONG BED

Available on Pro, SLE, SLT, Denali and Denali Ultimate in single- or dual-rear-wheel configurations. Available on AT4 in single-rear-wheel configuration only.

SIERRA HD 2500 REGULAR CAB

Sierra 2500 Heavy Duty comes in 2WD and 4WD Regular Cab models with an 8' long bed.

INSIDE BED HEIGHT

21.0"

GROUND CLEARANCE

10.2"

WHEELBASE

142.0"

MAX CARGO VOLUME83.5 cu. ft.¹**VEHICLE WIDTH**

81.8"

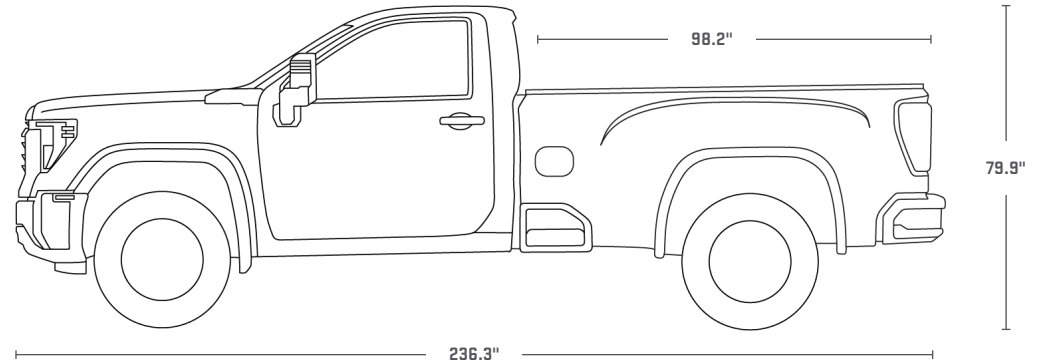
**SIERRA HD 3500 REGULAR CAB**

Sierra 3500 Heavy Duty comes in 2WD and 4WD Regular Cab models with an 8' long bed SRW or DRW configuration.

INSIDE BED HEIGHT

21.0"

GROUND CLEARANCE

SRW: 11.2"

DRW: 10.5"

WHEELBASE

142.0"

MAX CARGO VOLUME83.5 cu. ft.¹**VEHICLE WIDTH**

SRW: 81.9"

DRW: 96.6"

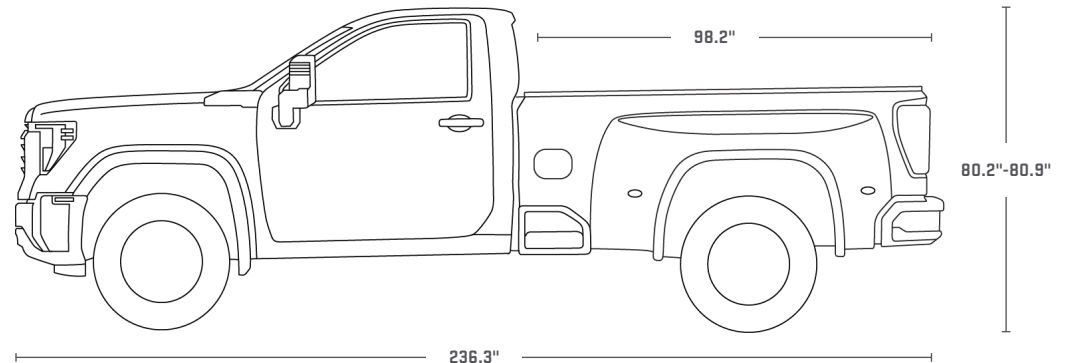

SIERRA HD 2500 DOUBLE CAB

Sierra 2500 Heavy Duty comes in 2WD and 4WD Double Cab models with a 6' 9" standard bed or an available 8' long bed.

INSIDE BED HEIGHT

21.0"

GROUND CLEARANCE

10.1"-10.2"

WHEELBASE

149.0"-162.0"

MAX CARGO VOLUME

69.6-83.5 cu. ft.¹

VEHICLE WIDTH

81.9"

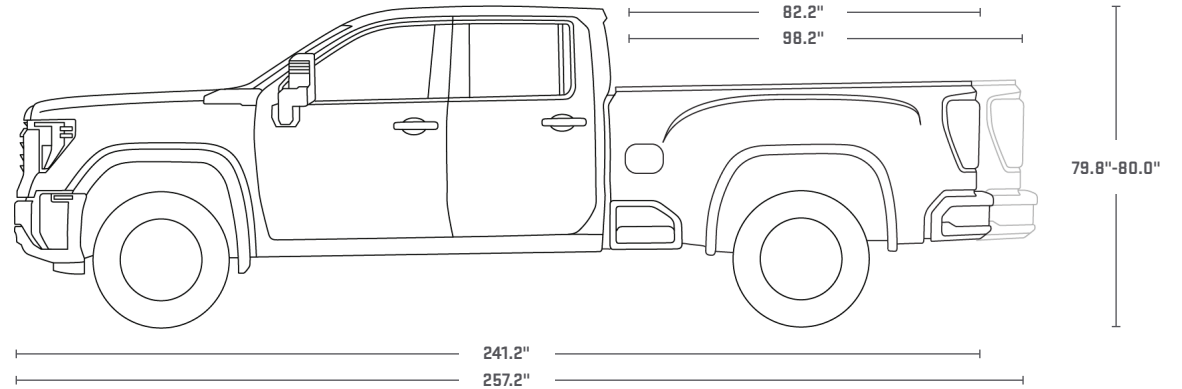
**SIERRA HD 3500 DOUBLE CAB**

Sierra 3500 Heavy Duty comes in 2WD and 4WD Double Cab models with an 8' long bed SRW or DRW configuration.

INSIDE BED HEIGHT

21.0"

GROUND CLEARANCE

SRW: 11.2"

DRW: 10.4"

WHEELBASE

162.0"

MAX CARGO VOLUME

83.5 cu. ft.¹

VEHICLE WIDTH

SRW: 81.9"

DRW: 96.6"

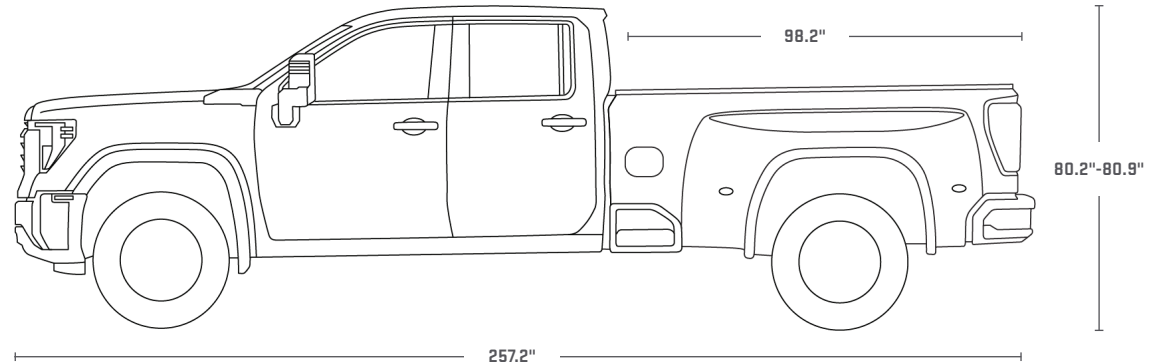

SIERRA HD 2500 CREW CAB

Sierra 2500 Heavy Duty comes in 2WD and 4WD Crew Cab models with a 6' 9" standard bed or an available 8' long bed.

INSIDE BED HEIGHT

21.0"

GROUND CLEARANCE

10.1"-11.8"

WHEELBASE

159.0"-172.0"

MAX CARGO VOLUME

69.6-83.5 cu. ft.¹

VEHICLE WIDTH

81.9"

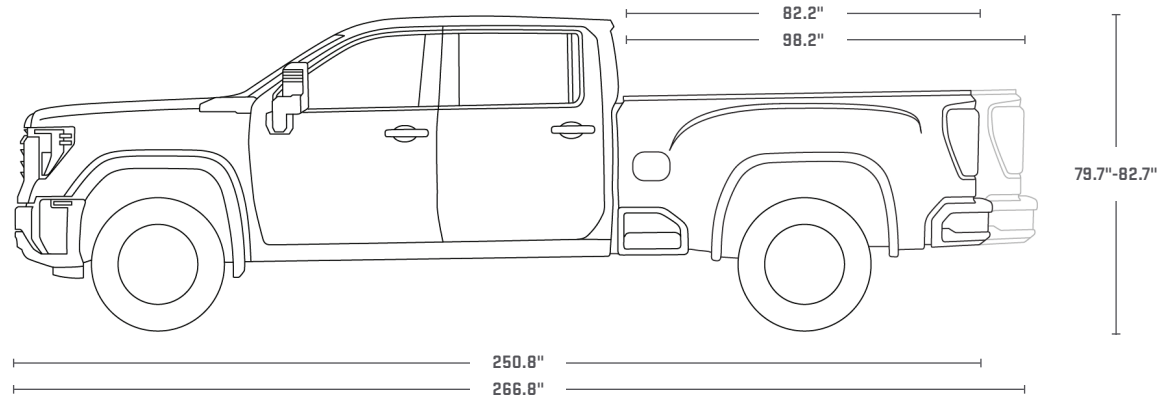

SIERRA HD 3500 CREW CAB

Sierra 3500 Heavy Duty comes in 2WD and 4WD Crew Cab models with either a 6' 9" standard bed or an available 8' long bed. Long bed is available with a SRW or DRW configuration.

INSIDE BED HEIGHT

21.0"

GROUND CLEARANCE

SRW: 11.1"-11.2"

DRW: 10.4"

WHEELBASE

159.0"-172.0"

MAX CARGO VOLUME

69.6-83.5 cu. ft.¹

VEHICLE WIDTH

SRW: 81.9"

DRW: 96.6"

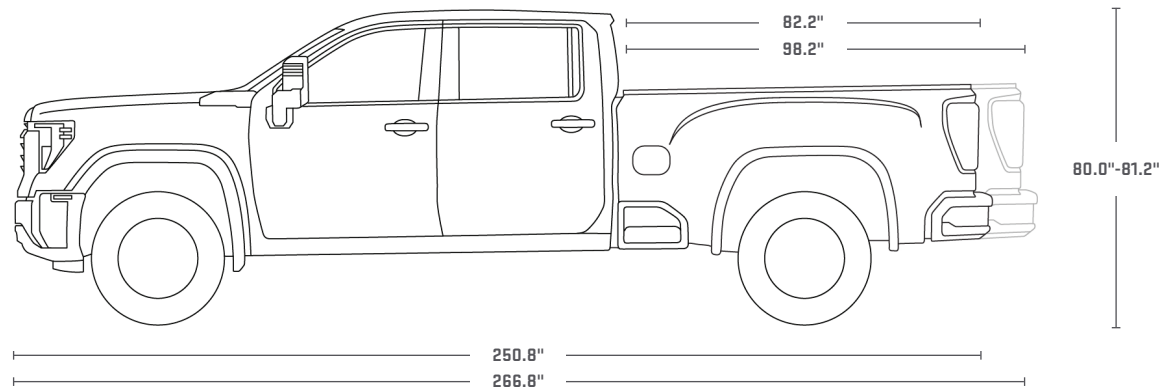

¹Cargo and load capacity limited by weight and distribution.



KEY TRAILERING FEATURES

- | Available Adaptive Cruise Control¹ with trailering
- | Up to 14 available camera views²
- | Available ProGrade Trailering System with in-vehicle Trailering App³
- | Available Traction Select System with Tow/Haul mode
- | Available smart trailer integration
- | Available Trailer Side Blind Zone Alert⁴
- | Available World's First Six-Function GMC MultiPro Tailgate
- | Available trailering-assistance technologies:¹ Jack-Knife Alert and Trailer Length Indicator for compatible conventional trailers

KEY SPECIFICATIONS

- | Maximum available gooseneck trailering: 36,000 lbs⁴
- | Maximum available fifth-wheel trailering: 32,000 lbs⁵
- | Maximum available conventional trailering: 20,000 lbs⁶
- | Maximum available horsepower: 470⁷
- | Maximum available torque: 975 lb-ft⁷
- | Maximum available payload: 7,234 lbs⁸
- | Maximum cargo bed volume: 83.5 cu. ft.⁹
- | 12 cargo tie-downs rated at 500 lbs¹⁰ per corner
- | Maximum available seating capacity of 6¹¹

POWERTRAIN

- | Available 6.6L Duramax Turbo Diesel V8 engine paired with an Allison 10-speed automatic transmission
- | 6.6L gas V8 engine paired with an Allison 10-speed automatic transmission

¹Safety or driver-assistance features are no substitute for the driver's responsibility to operate the vehicle in a safe manner. Read the vehicle Owner's Manual for important feature limitations and information. ²Safety or driver-assistance features are no substitute for the driver's responsibility to operate the vehicle in a safe manner. Read the vehicle Owner's Manual for important feature limitations and information. Some camera views require available accessory camera and installation. Not compatible with all trailers. See your dealer for details. ³App functionality and features vary with vehicle equipment and trim level. Data connection may be required. Some features require active service plan and working electrical system. Terms and limitations apply. ⁴36,000-lb rating requires properly equipped 3500 HD Regular Cab long bed 2WD DRW model with available 6.6L Duramax Turbo Diesel V8 engine, Max Trailering Package, Gooseneck/Fifth-Wheel Prep Package and gooseneck hitch. Maximum trailering ratings are intended for comparison purposes only. Before you buy a vehicle or use it for trailering, carefully review the trailering section of the Owner's Manual. The trailering capacity of your specific vehicle may vary. The weight of passengers, cargo and options or accessories may reduce the amount you can trailer. ⁵32,000-lb rating requires properly equipped 3500 HD Regular Cab long bed DRW 2WD model equipped with available 6.6L Duramax Turbo Diesel V8 engine and fifth-wheel hitch. Maximum trailering ratings are intended for comparison purposes only. Before you buy a vehicle or use it for trailering, carefully review the trailering section of the Owner's Manual. The trailering capacity of your specific vehicle may vary. The weight of passengers, cargo and options or accessories may reduce the amount you can trailer. ⁶Requires properly equipped 2500 HD Crew Cab model with available 6.6L Duramax Turbo Diesel V8 Engine, Trailer Brake Controller, Max Trailering Package and 18" or 20" wheels and tires or properly equipped 3500 HD model with available 6.6L Duramax Turbo Diesel V8 engine. See pages 18 and 19 for more details. Maximum trailering ratings are intended for comparison purposes only. Before you buy a vehicle or use it for trailering, carefully review the trailering section of the Owner's Manual. The trailering capacity of your specific vehicle may vary. The weight of passengers, cargo and options or accessories may reduce the amount you can trailer. ⁷Requires available 6.6L Duramax Turbo Diesel V8 engine. ⁸Requires properly equipped 3500 HD Regular Cab DRW long bed 2WD model with 6.6L gas V8 engine. These maximum payload ratings are intended for comparison purposes only. Before you buy a vehicle or use it to haul people or cargo, carefully review the vehicle loading section of the Owner's Manual and check the carrying capacity of your specific vehicle on the label on the inside of the driver's doorjamb. ⁹Requires long bed model. Cargo and load capacity limited by weight and distribution. ¹⁰Cargo and load capacity limited by weight and distribution. ¹¹Requires Double Cab or Crew Cab model with front 40/20/40 bench seat.

6.6L DURAMAX TURBO DIESEL V8 ENGINE SPECIFICATIONS

MODEL	CAB	BED	MAX GVWR (LBS) ¹	MAX GCWR (LBS) ²	MAX CONVENTIONAL TRAILER WEIGHT RATING (LBS) ³	MAX FIFTH-WHEEL TRAILER WEIGHT RATING (LBS) ³	MAX GOOSENECK TRAILER WEIGHT RATING (LBS) ³	MAX PAYLOAD (LBS) ⁴
2500	Regular 2WD	Long	10,750	26,000	14,500	18,500	18,500	3,813
	Regular 2WD (w/Max Trailing Package ⁵)	Long	11,200	30,000	14,500	22,430	22,430	4,094
	Regular 4WD	Long	10,960	26,000	14,500	18,200	18,200	3,675
	Regular 4WD (w/Max Trailing Package ⁵)	Long	11,450	30,000	14,500	22,050	22,050	3,958
	Double 2WD	Standard	10,900	26,000	14,500	18,200	18,200	3,618
	Double 4WD	Standard	11,200	26,000	14,500	17,900	17,900	3,572
	Double 2WD	Long	11,100	26,000	17,900	18,000	18,000	3,645
	Double 4WD	Long	11,450	26,000	17,600	17,700	17,700	3,691
	Crew 2WD	Standard	11,050	27,500	18,500	19,200	19,200	3,618
	Crew 2WD (w/Max Trailing Package ⁵)	Standard	11,500	30,000	20,000	21,510	21,510	3,903
	Crew 4WD	Standard	11,350	27,500	18,500 ⁶	19,100 ⁶	19,100 ⁶	3,587 ⁷
	Crew 4WD (w/Max Trailing Package ⁵)	Standard	11,750	30,000	20,000	21,600 ⁸	21,600 ⁸	3,829 ⁹
	Crew 2WD	Long	11,200	27,500	18,500	19,200	19,200	3,645
	Crew 2WD (w/Max Trailing Package ⁵)	Long	11,550	30,300	20,000	22,070	22,070	3,792
	Crew 4WD	Long	11,550	27,500	18,500 ¹⁰	19,000 ¹⁰	19,000 ¹⁰	3,702 ¹¹
Crew 4WD (w/Max Trailing Package ⁵)	Long	11,900	30,000	20,000	21,500 ¹²	21,500 ¹²	3,877 ¹³	

¹Maximum Gross Vehicle Weight Rating (GVWR). When properly equipped; includes weight of vehicle, passengers, cargo and equipment. ²Gross Combination Weight Rating (GCWR) when properly equipped; includes weight of vehicle and trailer combination, including the weight of driver, passengers, fuel, optional equipment and cargo in the vehicle and trailer. ³Requires properly equipped vehicle. Maximum trailering ratings are intended for comparison purposes only. Before you buy a vehicle or use it for trailering, carefully review the trailering section of the Owner's Manual. The trailering capacity of your specific vehicle may vary. The weight of passengers, cargo and options or accessories may reduce the amount you can trailer. ⁴These maximum payload ratings are intended for comparison purposes only. Before you buy a vehicle or use it to haul people or cargo, carefully review the vehicle loading section of the Owner's Manual and check the carrying capacity of your specific vehicle on the label on the inside of the driver's doorjamb. ⁵Requires available Integrated Trailer Brake Controller, 18" or 20" wheels and tires and spray-on bed liner. ⁶AT4 max conventional rating is 12,000 lbs when equipped with LT275/70R18 mud-terrain, blackwall tires. AT4 max fifth-wheel/gooseneck rating is 17,300 lbs. Denali max fifth-wheel/gooseneck rating is 17,600 lbs. Denali Ultimate max fifth-wheel/gooseneck rating is 17,200 lbs. ⁷AT4 max rating is 3,071 lbs. Denali max rating is 3,129 lbs. Denali Ultimate max rating is 3,060 lbs. ⁸AT4 max rating is 20,800 lbs. Denali max rating is 19,900 lbs. Denali Ultimate max rating is 19,300 lbs. ⁹AT4 max rating is 3,827 lbs. Denali max rating is 3,462 lbs. Denali Ultimate max rating is 3,368 lbs. ¹⁰AT4 max conventional rating is 12,000 lbs when equipped with LT275/70R18 mud-terrain, blackwall tires. AT4 max fifth-wheel/gooseneck rating is 18,000 lbs. Denali max fifth-wheel/gooseneck rating is 18,400 lbs. Denali Ultimate max fifth-wheel/gooseneck rating is 17,900 lbs. ¹¹AT4 max rating is 3,174 lbs. Denali max rating is 3,231 lbs. Denali Ultimate max rating is 3,162 lbs. ¹²AT4 max rating is 21,190 lbs. Denali max rating is 19,820 lbs. Denali Ultimate max rating is 19,190 lbs. ¹³AT4 max rating is 3,654 lbs. Denali max rating is 3,448 lbs. Denali Ultimate max rating is 3,355 lbs.

6.6L DURAMAX TURBO DIESEL V8 ENGINE SPECIFICATIONS CONTINUED

MODEL	CAB	BED	MAX GVWR (LBS) ¹	MAX GCWR (LBS) ²	MAX CONVENTIONAL TRAILER WEIGHT RATING (LBS) ³	MAX FIFTH-WHEEL TRAILER WEIGHT RATING (LBS) ³	MAX GOOSENECK TRAILER WEIGHT RATING (LBS) ³	MAX PAYLOAD (LBS) ⁴
3500 SRW	Regular 2WD	Long	11,500	30,000	14,500	22,430	22,430	4,403
	Regular 4WD	Long	11,800	30,000	14,500	22,050	22,050	4,327
	Double 2WD	Long	11,850	30,000	20,000	21,900	21,900	4,228
	Double 4WD	Long	12,150	30,000	20,000	21,590	21,590	4,220
	Crew 2WD	Standard	11,750	30,000	20,000	21,900	21,900	4,151
	Crew 4WD	Standard	12,100	30,000	20,000	21,600 ⁵	21,600 ⁵	4,180 ⁶
	Crew 2WD	Long	11,900	30,300	20,000	22,070	22,070	4,145
	Crew 4WD	Long	12,250	30,000	20,000	21,510 ⁷	21,510 ⁷	4,236 ⁸
3500 DRW	Regular 2WD	Long	14,000	43,500	20,000	32,000	35,500	6,584
	Regular 2WD (w/Max Trailing Package ⁹)	Long	14,000	43,900	20,000	32,000	36,000	6,489
	Regular 4WD	Long	14,000	40,000	20,000	31,500	31,500	6,209
	Double 2WD	Long	14,000	40,000	20,000	31,580	31,580	6,059
	Double 4WD	Long	14,000	40,000	20,000	31,280	31,280	5,752
	Crew 2WD	Long	14,000	40,000	20,000	31,450	31,450	5,926
	Crew 4WD	Long	14,000	40,000	20,000	31,000 ¹⁰	31,000 ¹⁰	5,667 ¹¹

¹Maximum Gross Vehicle Weight Rating (GVWR). When properly equipped; includes weight of vehicle, passengers, cargo and equipment. ²Gross Combination Weight Rating (GCWR) when properly equipped; includes weight of vehicle and trailer combination, including the weight of driver, passengers, fuel, optional equipment and cargo in the vehicle and trailer. ³Requires properly equipped vehicle. Maximum trailering ratings are intended for comparison purposes only. Before you buy a vehicle or use it for trailering, carefully review the trailering section of the Owner's Manual. The trailering capacity of your specific vehicle may vary. The weight of passengers, cargo and options or accessories may reduce the amount you can trailer. ⁴These maximum payload ratings are intended for comparison purposes only. Before you buy a vehicle or use it to haul people or cargo, carefully review the vehicle loading section of the Owner's Manual and check the carrying capacity of your specific vehicle on the label on the inside of the driver's doorjamb. ⁵AT4 max rating is 21,300 lbs. Denali max rating is 21,200 lbs. Denali Ultimate max rating is 21,100 lbs. ⁶AT4 max rating is 3,885 lbs. Denali max rating is 3,817 lbs. Denali Ultimate max rating is 3,748 lbs. ⁷AT4 max rating is 21,200 lbs. Denali max rating is 21,100 lbs. Denali Ultimate max rating is 21,000 lbs. ⁸AT4 max rating is 3,929 lbs. Denali max rating is 3,861 lbs. Denali Ultimate max rating is 3,793 lbs. ⁹Requires available Convenience Package. ¹⁰Denali max rating is 30,800 lbs. Denali Ultimate max rating is 30,700 lbs. ¹¹Denali max rating is 5,323 lbs. Denali Ultimate max rating is 5,254 lbs.

6.6L GAS V8 ENGINE SPECIFICATIONS

MODEL	CAB	BED	MAX GVWR (LBS) ¹	MAX GCWR (LBS) ²	MAX CONVENTIONAL TRAILER WEIGHT RATING (LBS) ³	MAX FIFTH-WHEEL TRAILER WEIGHT RATING (LBS) ³	MAX GOOSENECK TRAILER WEIGHT RATING (LBS) ³	MAX PAYLOAD (LBS) ⁴
2500	Regular 2WD	Long	10,350	26,000	14,500	18,700	18,700	4,039
	Regular 4WD	Long	10,650	26,000	14,500	18,300	18,300	3,992
	Double 2WD	Standard	10,450	26,000	14,500	18,600	18,600	3,822
	Double 4WD	Standard	10,750	26,000	14,500	18,200	18,200	3,775
	Double 2WD	Long	10,600	26,000	16,000	18,400	18,400	3,838
	Double 4WD	Long	10,950	26,000	16,000	18,000	18,000	3,884
	Crew 2WD	Standard	10,550	26,000	16,000	18,500	18,500	3,818
	Crew 4WD	Standard	10,850	26,000	16,000 ⁵	18,400 ⁵	18,400 ⁵	3,787 ⁶
	Crew 2WD	Long	10,700	26,000	16,000	18,500	18,500	3,853
	Crew 4WD	Long	11,050	26,000	16,000 ⁷	18,370 ⁷	18,370 ⁷	3,895 ⁸
3500 SRW	Regular 2WD	Long	10,950	26,000	14,500	19,080	19,080	4,502
	Regular 4WD	Long	11,300	26,000	14,500	18,700	18,700	4,477
	Double 2WD	Long	11,300	26,000	16,000	18,620	18,620	4,394
	Double 4WD	Long	11,600	26,000	16,000	18,310	18,310	4,387
	Crew 2WD	Standard	11,200	26,000	16,000	18,650	18,650	4,324
	Crew 4WD	Standard	11,550	26,000	16,000	18,300 ⁹	18,300 ⁹	4,353 ¹⁰
	Crew 2WD	Long	11,350	26,000	16,000	18,510	18,510	4,331
	Crew 4WD	Long	11,700	26,000	16,000	18,230 ¹¹	18,230 ¹¹	4,402 ¹²
3500 DRW	Regular 2WD	Long	14,000	26,000	18,700	18,760	18,760	7,234
	Regular 4WD	Long	14,000	26,000	18,400	18,380	18,380	6,859
	Double 2WD	Long	14,000	26,000	18,300	18,300	18,300	6,776
	Double 4WD	Long	14,000	26,000	18,000	17,990	17,990	6,464
	Crew 2WD	Long	14,000	26,000	18,200	18,240	18,240	6,663
	Crew 4WD	Long	14,000	26,000	17,800 ¹³	17,800 ¹³	17,800 ¹³	6,384 ¹⁴

¹Maximum Gross Vehicle Weight Rating (GVWR). When properly equipped; includes weight of vehicle, passengers, cargo and equipment. ²Gross Combination Weight Rating (GCWR) when properly equipped; includes weight of vehicle and trailer combination, including the weight of driver, passengers, fuel, optional equipment and cargo in the vehicle and trailer. ³Requires properly equipped vehicle. Maximum trailering ratings are intended for comparison purposes only. Before you buy a vehicle or use it for trailering, carefully review the trailering section of the Owner's Manual. The trailering capacity of your specific vehicle may vary. The weight of passengers, cargo and options or accessories may reduce the amount you can trailer. ⁴These maximum payload ratings are intended for comparison purposes only. Before you buy a vehicle or use it to haul people or cargo, carefully review the vehicle loading section of the Owner's Manual and check the carrying capacity of your specific vehicle on the label on the inside of the driver's doorjamb. ⁵AT4 max conventional rating is 12,000 lbs when equipped with LT275/70R18 mud-terrain, blackwall tires. AT4 max fifth-wheel/gooseneck rating is 18,000 lbs. Denali max fifth-wheel/gooseneck rating is 18,000 lbs. ⁶AT4 max rating is 3,383 lbs. Denali max rating is 3,346 lbs. ⁷AT4 max conventional rating is 12,000 lbs when equipped with LT275/70R18 mud-terrain, blackwall tires. AT4 max fifth-wheel/gooseneck rating is 17,900 lbs. Denali max fifth-wheel/gooseneck rating is 17,900 lbs. ⁸AT4 max rating is 3,440 lbs. Denali max rating is 3,442 lbs. ⁹AT4 max rating is 17,900 lbs. Denali max rating is 17,900 lbs. ¹⁰AT4 max rating is 4,005 lbs. Denali max rating is 4,007 lbs. ¹¹AT4 max rating is 17,800 lbs. Denali max rating is 17,800 lbs. ¹²AT4 max rating is 4,043 lbs. Denali max rating is 4,045 lbs. ¹³Denali max rating is 17,500 lbs. ¹⁴Denali max rating is 6,007 lbs.

Most Sierra 2500 Heavy Duty models offer a 10,000-lb GVWR option for small businesses and commercial buyers. Contact the U.S. Department of Transportation and your local Department of Transportation to determine whether you may have additional registration or licensing requirements for these trucks.

10,000-LB GVWR AND UNDER SPECIFICATIONS

MODEL	CAB	BED	MAX GVWR (LBS) ¹	MAX GCWR (LBS) ²	MAX CONVENTIONAL TRAILER WEIGHT RATING (LBS) ³	MAX FIFTH-WHEEL TRAILER WEIGHT RATING (LBS) ³	MAX GOOSENECK TRAILER WEIGHT RATING (LBS) ³	MAX PAYLOAD (LBS) ⁴
6.6L DURAMAX TURBO DIESEL V8 ENGINE								
2500	Double 4WD	Standard	10,000	24,500	14,500	12,640	12,640	2,372
2500	Double 4WD	Long	10,000	24,500	14,500	11,770	11,770	2,241
2500	Crew 2WD with 17" wheels	Standard	10,000	24,500	14,500	13,950	13,950	2,568
2500	Crew 2WD with 18" or 20" wheels	Standard	10,000	26,000	18,000	13,950	13,950	2,568
2500	Crew 4WD with 17" wheels	Standard	10,000	24,500	14,500	11,740	11,740	2,237
2500	Crew 4WD with 18" or 20" wheels	Standard	10,000	26,000	17,800	11,740	11,740	2,237
2500	Crew 2WD with 17" wheels	Long	10,000	24,500	14,500	13,120	13,120	2,445
2500	Crew 2WD with 18" or 20" wheels	Long	10,000	26,000	17,800	13,120	13,120	2,445
2500	Crew 4WD with 17" wheels	Long	10,000	24,500	14,500	11,170	11,170	2,152
2500	Crew 4WD with 18" or 20" wheels	Long	10,000	26,000	17,700	11,170	11,170	2,152
6.6L GAS V8 ENGINE								
2500	Regular 2WD	Long	9,900	24,500	14,500	17,710	17,710	3,589
2500	Regular 4WD	Long	10,000	24,500	14,500	17,370	17,370	3,342
2500	Double 2WD	Standard	10,000	24,500	14,500	17,390	17,390	3,372
2500	Double 4WD	Standard	10,000	24,500	14,500	17,000	17,000	3,025
2500	Double 2WD	Long	10,000	24,500	14,500	17,260	17,260	3,238
2500	Double 4WD	Long	10,000	24,500	14,500	16,390	16,390	2,934
2500	Crew 2WD with 17" wheels	Standard	10,000	24,500	14,500	17,290	17,290	3,268
2500	Crew 2WD with 18" or 20" wheels	Standard	10,000	24,500	16,000	17,290	17,290	3,268
2500	Crew 4WD with 17" wheels	Standard	10,000	24,500	14,500	16,410	16,410	2,937
2500	Crew 4WD with 18" or 20" wheels	Standard	10,000	26,000	16,000	16,410	16,410	2,937
2500	Crew 2WD with 17" wheels	Long	10,000	24,500	14,500	17,200	17,200	3,153
2500	Crew 2WD with 18" or 20" wheels	Long	10,000	26,000	16,000	17,200	17,200	3,153
2500	Crew 4WD with 17" wheels	Long	10,000	24,500	14,500	15,790	15,790	2,845
2500	Crew 4WD with 18" or 20" wheels	Long	10,000	26,000	16,000	15,790	15,790	2,845

¹Maximum Gross Vehicle Weight Rating (GVWR). When properly equipped; includes weight of vehicle, passengers, cargo and equipment. ²Gross Combination Weight Rating (GCWR) when properly equipped; includes weight of vehicle and trailer combination, including the weight of driver, passengers, fuel, optional equipment and cargo in the vehicle and trailer. ³Requires properly equipped vehicle. Maximum trailering ratings are intended for comparison purposes only. Before you buy a vehicle or use it for trailering, carefully review the trailering section of the Owner's Manual. The trailering capacity of your specific vehicle may vary. The weight of passengers, cargo and options or accessories may reduce the amount you can trailer. ⁴These maximum payload ratings are intended for comparison purposes only. Before you buy a vehicle or use it to haul people or cargo, carefully review the vehicle loading section of the Owner's Manual and check the carrying capacity of your specific vehicle on the label on the inside of the driver's doorjamb.



ENGINE SPECIFICATIONS

ENGINE	BORE & STROKE (IN./MM)	BLOCK MATERIAL	CYLINDER HEAD MATERIAL	COMPRESSION RATIO	VALVETRAIN	FUEL DELIVERY	HORSEPOWER	TORQUE
6.6L Duramax Turbo Diesel V8	4.05 x 3.89 / 103 x 99	Cast iron	Cast aluminum	16.0:1	Overhead valve, four valves per cylinder	Common-rail direct fuel injection	470 @ 2800	975 @ 1600
6.6L gas V8	4.06 x 3.86 / 103.25 x 98	Cast iron with nodular iron main caps	Cast aluminum	10.75:1	Overhead valve, two valves per cylinder, Variable Valve Timing	Direct fuel injection	401 @ 5200	464 @ 4000

TRANSMISSION SPECIFICATIONS

TRANSMISSION TYPE	GEAR RATIOS (:1)	FIRST	SECOND	THIRD	FOURTH	FIFTH	SIXTH	SEVENTH	EIGHTH	NINTH	TENTH	REVERSE	FINAL DRIVE RATIO
Allison 10-speed automatic (6.6L gas V8 and 6.6L Duramax Turbo Diesel V8)	10L1000	4.54	2.87	2.06	1.72	1.48	1.26	1.00	0.85	0.69	0.63	4.54	3.42 (diesel)/ 3.73 (gas)



PROGRADE TRAILERING SYSTEM

GMC’s available ProGrade Trailing System includes advanced technologies for increased views and confidence. It helps when hooking up your trailer, while on the road and when backing your trailer into place.

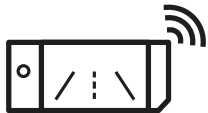

IN-VEHICLE TRAILERING APP¹

The available in-vehicle Trailing App¹ is integrated into the infotainment system² and includes the ability to create five defined trailer profiles based on trailer name, trailer type and trailer hitch type. There are also maintenance reminders, predeparture checklists, a Trailer Light Sequence Test, a Trailer Tire Pressure Monitoring System³ and a counter for trailer mileage and fuel economy.



myGMC MOBILE APP⁴

The available myGMC Mobile App⁴ allows you to create and manage trailer profiles (shareable with other compatible Sierra owners), run a Trailer Light Sequence Test to help ensure trailer lights are in working order, reference predeparture checklists and use a Trailer Load Calculator to determine the combined weight of your vehicle and trailer. You can view and receive alerts on key components of your trailer such as tire pressure monitoring³ and trailer miles. There’s also a glossary filled with trailering-related materials.

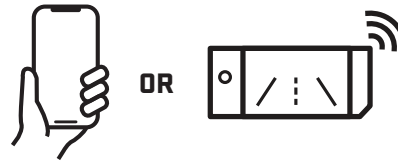

SMART TRAILER INTEGRATION

The available ASA Electronics iN•Command[®] Control System⁵ is designed to integrate with and be accessible through the myGMC Mobile App⁴ (on compatible iPhones[®] and Android[™] smartphones) or on the infotainment system via Apple CarPlay^{®6} and Android Auto⁷ compatibility. The iN•Command Control System allows you to monitor and control a range of smart system functions such as water tank levels, climate controls and power slide-outs in recreational trailers equipped with GlobalConnect technology.

¹App functionality and features vary with vehicle equipment and trim level. Data connection may be required. Some features require active service plan and working electrical system. Terms and limitations apply. ²Functionality varies by model. Full functionality requires compatible Bluetooth and smartphone, and USB connectivity for some devices. ³Requires available Trailer Tire Pressure Monitoring System and installation of trailer tire pressure monitor sensors. ⁴Available on select Apple[®] and Android devices. Service availability, features and functionality vary by vehicle, device and the plan you are enrolled in. Terms apply. Device data connection required. See onstar.com for details and limitations. ⁵iN•Command is provided by ASA Electronics and is designed to operate within 30 feet of the trailer. Works with trailers equipped with iN•Command Control System with GlobalConnect via Bluetooth connection. Control and monitoring functionality varies by trailer manufacturer model and installed options. Use of the iN•Command Control System feature through the myGMC Mobile App requires an active service plan. User terms apply. See onstar.com for details and limitations. ⁶Vehicle user interface is a product of Apple[®] and its terms and privacy statements apply. Requires compatible iPhone[®] and data plan rates apply. Apple CarPlay is a trademark of Apple, Inc. Siri, iPhone and iTunes are trademarks of Apple, Inc., registered in the U.S. and other countries. ⁷Vehicle user interface is a product of Google, and its terms and privacy statements apply. Wireless use of Android Auto requires a compatible Android 11.0+ phone and compatible active data plan. Check g.co/androidauto/requirements for compatibility. Android and Android Auto are trademarks of Google LLC.

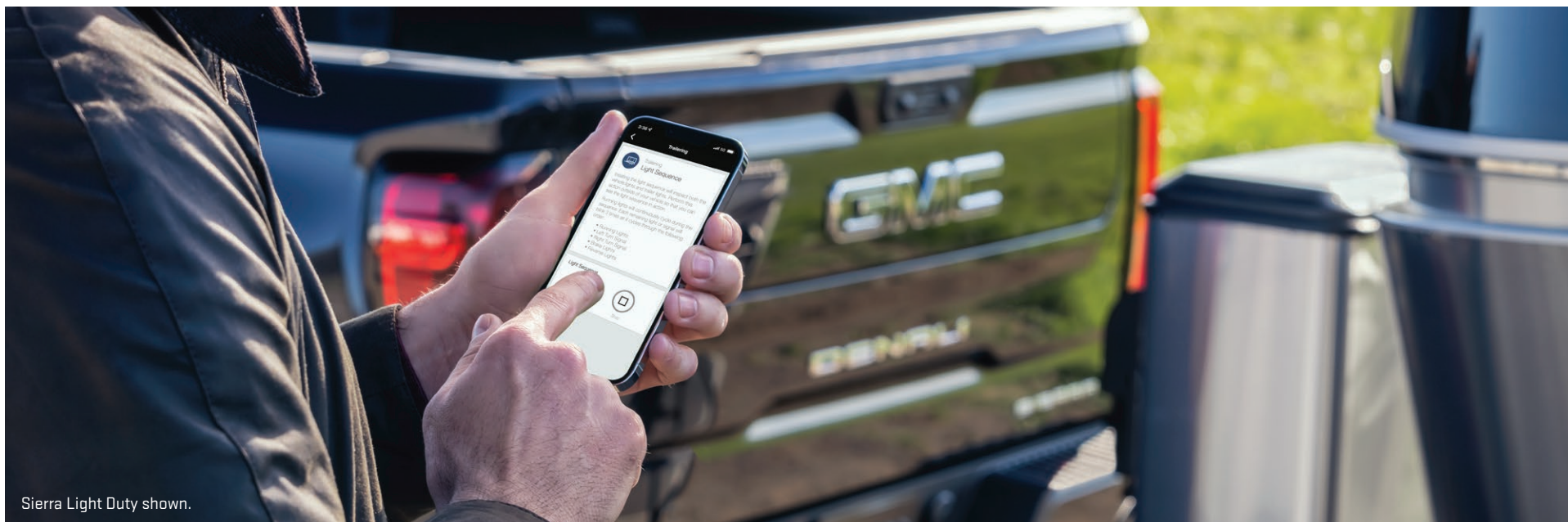

Sierra Light Duty shown.

INNOVATIVE WAYS TO TAKE CONTROL

The available myGMC Mobile App¹ helps elevate your ownership experience in many ways. It's also a powerful and useful tool when it comes to trailering.

IN A PROPERLY EQUIPPED VEHICLE, YOU'LL HAVE THESE USEFUL FUNCTIONS AT YOUR FINGERTIPS:

- | Trailer Light Sequence Test
- | Load calculator
- | Predeparture checklists
- | Profile sharing
- | Glossary of terms
- | Trailer tire pressure alerts²
- | Maintenance reminders
- | Mileage and fuel economy counter
- | Smart trailer controls

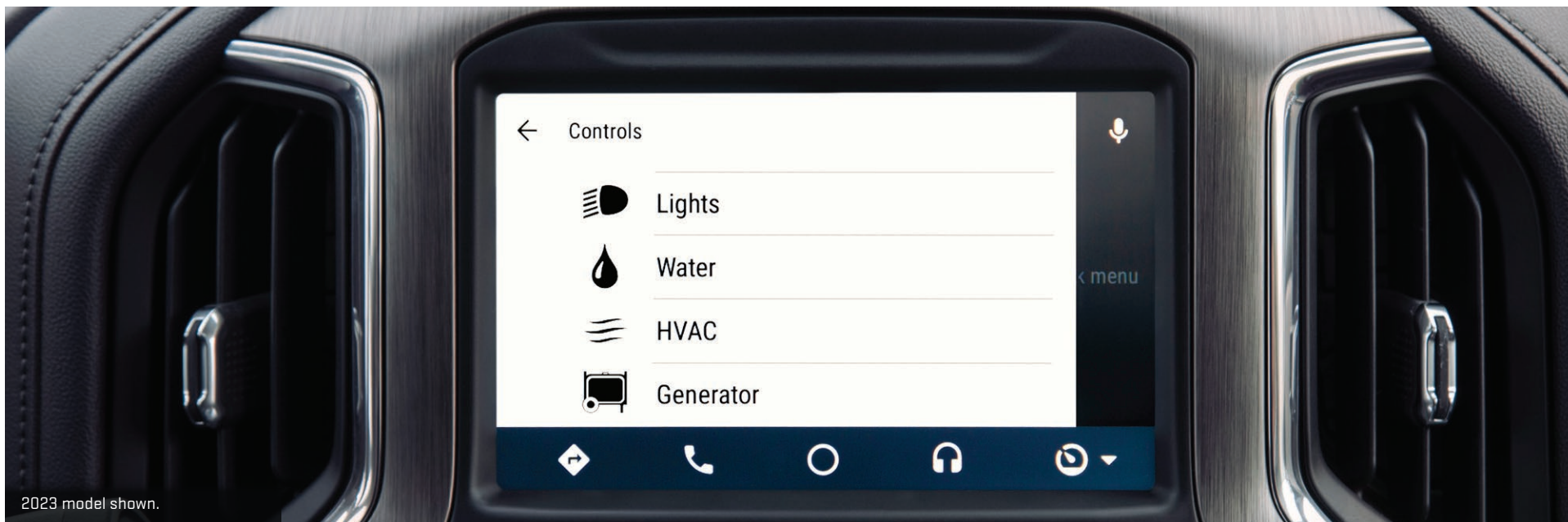

2023 model shown.

PUTTING YOU IN COMMAND LIKE NEVER BEFORE

The available Smart Trailer Control System effectively turns your smartphone into a remote control. Accessible through the available myGMC Mobile App¹ or through the infotainment system (via Apple CarPlay^{®2} and Android Auto³ compatibility), the Smart Trailer Control System allows you to control many of your compatibly equipped iN-Command Control System⁴ trailer functions through a Bluetooth⁵ connection. It's a seamless way to stay informed and in command.

TAKE CONTROL OF THE FOLLOWING FUNCTIONS AND SYSTEMS IN YOUR COMPATIBLE ATTACHED TRAILER:

- | Adjust climate controls
- | Turn the water pump on/off
- | Turn the heater on/off
- | Turn interior lights on/off
- | Turn exterior lights on/off
- | Check real-time status of the water tank level
- | Check real-time status of the battery life
- | Check fuel level of the generator
- | Prime and start the generator
- | Open and close slide-outs (vehicle and trailer must be parked)
- | Open and close awnings (vehicle and trailer must be parked)
- | Adjust jacks (vehicle and trailer must be parked)

¹Available on select Apple[®] and Android devices. Service availability, features and functionality vary by vehicle, device and the plan you are enrolled in. Terms apply. Device data connection required. See onstar.com for details and limitations. ²Vehicle user interface is a product of Apple[®] and its terms and privacy statements apply. Requires compatible iPhone[®] and data plan rates apply. Apple CarPlay is a trademark of Apple, Inc., registered in the U.S. and other countries. ³Vehicle user interface is a product of Google, and its terms and privacy statements apply. Wireless use of Android Auto requires a compatible Android 11.0+ phone and compatible active data plan. Check g.co/androidauto/requirements for compatibility. Android and Android Auto are trademarks of Google LLC. ⁴iN-Command is provided by ASA Electronics and is designed to operate within 30 feet of the trailer. Works with trailers equipped with iN-Command Control System with GlobalConnect via Bluetooth connection. Control and monitoring functionality varies by trailer manufacturer model and installed options. Use of the iN-Command Control System feature through the myGMC Mobile App requires an active service plan. User terms apply. See onstar.com for details and limitations. ⁵The Bluetooth[®] word mark and logos are owned by Bluetooth SIG, Inc., and any use of such marks by General Motors is under license. Other trademarks and trade names are those of their respective owners. Go to my.gmc.com/learnabout/bluetooth to find out which phones are compatible with the vehicle. Full Bluetooth feature functionality varies by device, model and software version.



UP TO
14 AVAILABLE
CAMERA VIEWS¹

- 1. Transparent trailer view (requires compatible trailer)
- 2. Hitch View
- 3. Cargo bed view (with zoom view and Hitch Guidance)

- 4. Front camera view
- 5. Rear camera view
- 6. Surround view
- 7. Front top-down view
- 8. Rear top-down view
- 9. Front side view

- 10. Rear side view (with trailer biasing) (requires compatible trailer)
- 11. Rear trailer view (with guidelines and Trailer Angle Indicator) (requires compatible trailer)
- 12. Inside trailer view
- 13. Picture-in-picture side view
- 14. Rear Camera Mirror

¹Safety or driver-assistance features are no substitute for the driver's responsibility to operate the vehicle in a safe manner. Read the vehicle Owner's Manual for important feature limitations and information. Some camera views require available accessory camera and installation. Not compatible with all trailers. See your dealer for details.

CAMERA-VIEW COMPATIBILITY

ALL TRAILERS MAY NOT BE COMPATIBLE. THIS CHART IS FOR REFERENCE ONLY.

CAMERA VIEW	HITCH TYPE	TRAILER TYPE	DIMENSIONS REQUIRED
Rear trailer view with Trailer Angle Indicator ¹	Conventional ²	Box/enclosed ³	Yes
Rear trailer view ¹	Most	Most	N/A
Rear side view	Most	Most	N/A
Rear side view with trailer biasing	Most	Box/enclosed ³	Yes
Rear side view with Trailer Length Indicator (turn-signal activated)	Most	Most	Yes
Transparent trailer view ⁴	Most	Box/enclosed ³	Yes
Jack-Knife Alert	Conventional ²	Box/enclosed ³	Yes
Picture-in-picture side view ¹	Most	Most	N/A
Inside trailer view ¹	N/A	Most	N/A
Bed view	N/A	N/A	N/A
Bed view with zoom and Hitch Guidance	Fifth-wheel/gooseneck	Most	N/A
Hitch View	Conventional ²	Most	N/A

Safety or driver-assistance features are no substitute for the driver's responsibility to operate the vehicle in a safe manner. The driver should remain attentive to traffic, surroundings and road conditions at all times. Visibility, weather and road conditions may affect feature performance. Read the vehicle Owner's Manual for more important feature limitations and information.

¹Requires available accessory camera and installation. Not compatible with all trailers. See your dealer for details. ²Conventional trailer hitch type is any trailer that connects to a trailer hitch using a coupler and ball mount, as opposed to a fifth-wheel or gooseneck connection. ³Box/enclosed trailer is a type of trailer that has walls and a roof to completely enclose cargo and keep it protected from the elements. ⁴Requires available accessory camera and installation. Not compatible with all trailers. This camera view has a trailer-length limitation. See your dealer for details.

FOLLOW THESE CALIBRATION TIPS FOR SUCCESSFUL SETUP:**01.****DRIVE BELOW 31 MPH**

Driving faster may delay calibration.

02.**DRIVE STRAIGHT**

Excessive steering may extend calibration time.

03.**USE GOOD LIGHT**

Calibration should be attempted when there is enough light.

04.**SET UP IN GOOD WEATHER**

Calibration during snow or heavy rain should be avoided.

05.**USE A FLAT, DEFINED ROAD**

Avoid gravel, dirt or unmarked roads.

06.**USE THE PROPER CONNECTION**

Ensure that the camera is connected to the correct input.

07.**USE THE CORRECT LOCATION**

The accessory camera should be mounted and angled inside the defined mounting location (see camera installation instructions).

08.**CHECK FOR A CLEAN LENS**

Cameras obstructed by dirt or debris may hinder calibration.

09.**CHECK FOR A CLEAR VIEW**

The accessory trailer camera should have an unobstructed view (no spare tire, bike/cargo racks, etc.). Shadows may be perceived as obstructions. Attempt to calibrate while driving in an alternate direction if possible.

10.**ENSURE DIMENSIONS ARE CORRECT**

Enter accurate measurements made to the nearest inch.

11.**MEASURE CORRECTLY**

Use the width of the box of the trailer. Do not include the width of the wheels. This helps transparent trailer view and Jack-Knife Alert to work accurately.

12.**MEASURE V-NOSE TRAILERS CORRECTLY**

For V-nose trailers, when measuring the distance between the ball and the front of the trailer, you should measure the distance to the widest part of the trailer, not to the point on the nose.

SELECT TRAILERING TECHNOLOGY AVAILABILITY BY TRIM

See your GMC dealer or gmc.com for more details and requirements.

TRAILERING TECHNOLOGY

	PRO	SLE	SLT	AT4	AT4X	DENALI	DENALI ULTIMATE
In-vehicle Trailering App ¹	—	○	●	●	●	●	●
myGMC Mobile App ²	○	○	○	○	○	○	○
Smart trailer integration	○	○	○	○	○	○	○
Trailer Tire Pressure and Temperature Monitoring System ³	—	○	●	●	●	●	●
Tow/Haul mode	●	●	●	●	●	●	●
Auto Electric Parking Brake	—	○	●	●	●	●	●
Hill Start Assist	●	●	●	●	●	●	●
Diesel Exhaust Brake System	○	○	○	○	○	○	●
Trailering mirrors	●	●	●	●	●	●	●
Integrated trailer brake controller	○	●	●	●	●	●	●
Trailer Sway Control	●	●	●	●	●	●	●
Transmission temperature gauge	●	●	●	●	●	●	●

● Standard ○ Available — Not Available

CONTINUED

¹App functionality and features vary with vehicle equipment and trim level. Data connection may be required. Some features require active service plan and working electrical system. Terms and limitations apply. ²Available on select Apple® and Android devices. Service availability, features and functionality vary by vehicle, device and the plan you are enrolled in. Terms apply. Device data connection required. See onstar.com for details and limitations. ³Requires available Trailer Tire Pressure Monitoring System and installation of available trailer tire pressure monitor sensors.

SELECT TRAILERING TECHNOLOGY AVAILABILITY BY TRIMSee your GMC dealer or gmc.com for more details and requirements.**TRAILERING TECHNOLOGY CONTINUED**

	PRO	SLE	SLT	AT4	AT4X	DENALI	DENALI ULTIMATE
Hitch Guidance ¹	●	●	●	●	●	●	●
Hitch Guidance ¹ with Hitch View ¹	—	○	●	●	●	●	●
Rear Vision Camera ¹	●	●	●	●	●	●	●
High Definition Surround Vision ¹	—	○	○	●	●	●	●
Trailer hitch platform	●	●	●	●	●	●	●
7-wire harness with independent fused trailering circuits	●	●	●	●	●	●	●
7-pin and 4-pin connector	○	●	●	—	—	—	—
7-pin connector and 2 auxiliary camera ports	—	○	○	●	●	●	●
Up to 13 camera views, ² including transparent trailer view ³	—	○	○	—	—	—	—
Up to 14 camera views, ² including transparent trailer view ³	—	—	—	○	○	○	○
Rear trailer guidelines with Trailer Angle Indicator ⁴	—	○	○	○	○	○	○
Trailer Length Indicator ⁵	—	○	○	●	●	●	●
Jack-Knife Alert ⁵	—	○	○	●	●	●	●

● Standard ○ Available — Not Available

¹Safety or driver-assistance features are no substitute for the driver's responsibility to operate the vehicle in a safe manner. Read the vehicle Owner's Manual for important feature limitations and information. ²Safety or driver-assistance features are no substitute for the driver's responsibility to operate the vehicle in a safe manner. Read the vehicle Owner's Manual for important feature limitations and information. Some camera views require available accessory camera and installation. Not compatible with all trailers. See your dealer for details. ³Requires available accessory camera and installation. Not compatible with all trailers. This camera view has a trailer-length limitation. See your dealer for details. ⁴Requires available accessory camera and installation. Not compatible with all trailers. See your dealer for details. ⁵Feature not compatible with fifth-wheel or gooseneck trailers.

IMPORTANT TERMS

CURB WEIGHT

The weight of a vehicle with all of the standard and optional equipment and a full tank of fuel, but without any passengers or cargo.

GROSS VEHICLE WEIGHT (GVW)

The combined weight of the vehicle and all passengers and cargo.

GROSS VEHICLE WEIGHT RATING (GVWR)

This number is the maximum amount a tow vehicle may weigh. Everything that contributes to the weight of the tow vehicle is featured in this rating, including the weight of the vehicle, driver and all passengers, fuel, payload, tongue load of the trailer, the weight of the hitch and all optional equipment. The GVWR is displayed on the driver's door or door-lock pillar label of your GMC vehicle. The GVW must never exceed the GVWR.

GROSS COMBINED WEIGHT (GCW)

The GVW plus the loaded trailer weight.

GROSS COMBINED WEIGHT RATING (GCWR)

The total allowable weight of the completely loaded vehicle and trailer, including any fuel, passengers, cargo, equipment and accessories.

CARGO WEIGHT

The weight of all items added to the curb weight of the vehicle, including cargo and optional equipment. When towing, cargo weight also includes the trailer tongue or hitch weight.

MAX PAYLOAD

The maximum allowable weight of passengers plus cargo that the vehicle is designed to carry.

GROSS AXLE WEIGHT (GAW)

The total weight placed on a single axle (front or rear).

GROSS AXLE WEIGHT RATING (GAWR)

This is the weight that each axle is capable of supporting. The load on each axle must not exceed the GAWR. The GAWR for each GMC vehicle is displayed on the driver's door or door-lock pillar label.

GROSS TRAILER WEIGHT

The weight of a loaded trailer.

TONGUE (OR HITCH) WEIGHT

The tongue weight is the total amount of trailer weight that is pressing down on the trailer hitch. Keep in mind that the way a trailer is loaded affects the overall tongue weight and will also affect the handling of the tow vehicle when trailering.

TRAILER HITCH STYLES

SELECTING THE RIGHT HITCH

Choosing the right hitch, while ensuring proper electrical connections are made, affects how your vehicle handles, corners and brakes, and allows you to alert other drivers of your intentions. Before selecting a hitch or trailering package, you should be familiar with the weight ratings specific to your GMC vehicle.

WEIGHT-CARRYING HITCH

This consists of a hitch ball mounted on a step bumper or draw bar, or a tow eye latched to a pintle hook. Hitch balls are available in a range of sizes. Make sure that the diameter of your hitch ball matches your trailer coupler. Also check that the ball and ball mount meet or exceed the Gross Trailer Weight Rating.



HITCH BALL ON STEP BUMPER



HITCH BALL ON DRAW BAR

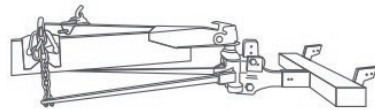

WEIGHT-DISTRIBUTING HITCH

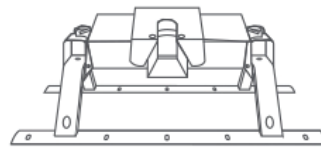

FIFTH-WHEEL HITCH

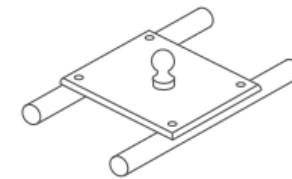

GOOSENECK HITCH

WEIGHT-DISTRIBUTING HITCH

This is most often used for heavier trailering. This hitch type more evenly distributes the trailer load by using spring bars to shift some of the hitch weight forward onto the tow vehicle's front axle and rearward to the trailer's axles.

FIFTH-WHEEL HITCH AND GOOSENECK HITCH

These are designed for heavy trailering. Located in the bed of the truck, these hitch types are most frequently used with travel trailers, horse trailers and other large trailers.

TRAILERING ON THE ROAD

CONVENTIONAL TRAILER

While typically used to describe recreational trailers, such as campers or boat trailers, conventional trailers generally utilize a ball-type hitch.

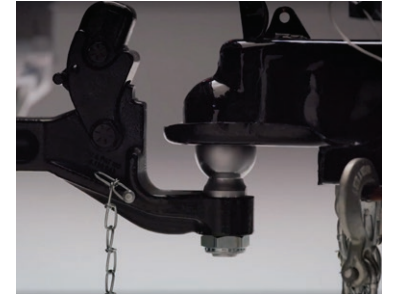

FIFTH-WHEEL TRAILER

Fifth-wheel trailers can be slightly larger than conventional trailers and offer a wide range of configurations. These trailers are designed specifically for pickups equipped with a fifth-wheel hitch.



GOOSENECK TRAILER

Gooseneck trailers place the hitch weight of the trailer over the rear axle of the truck rather than the rear bumper.

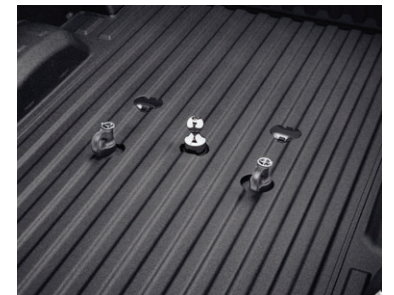

HOW TO READ A TRAILERING LABEL

Jul 28 2022 23:57:25 1F3 2GA3695051

gm TRAILERING INFORMATION 

XXXXXXXXXXXXXXXXXXXX

A **B** **C** **D** **E**

VEHICLE AND TRAILER MUST NOT EXCEED ANY OF THESE VALUES.

GVWR:	4972 KG / 10960 LBS
GCWR:	11793 KG / 26000 LBS
RGAWR:	2994 KG / 6600 LBS
CURB WEIGHT:	3397 KG / 7488 LBS
MAX PAYLOAD:	1575 KG / 3472 LBS

SAE J2807 TRAILER WEIGHT RATING (TWR) FOR VEHICLE CONFIGURATION.

CONVENTIONAL TWR:	6577 KG / 14500 LBS
MAX TONGUE WEIGHT:	658 KG / 1450 LBS
GOOSENECK TWR:	8237 KG / 18160 LBS
MAX TONGUE WEIGHT:	1238 KG / 2730 LBS

SEE OWNER'S MANUAL  FOR MORE INFORMATION

Included on all Sierra Heavy Duty models is a Trailering Information label.

A GVWR = GROSS VEHICLE WEIGHT RATING

This number is the maximum amount a tow vehicle may weigh. Everything that contributes to the weight of the tow vehicle is featured in this rating, including the weight of the vehicle, driver and all passengers, fuel, payload, tongue load of the trailer, the weight of the hitch and all optional equipment. The GVWR is displayed on the driver's door or door-lock pillar label of your GMC vehicle. The Gross Vehicle Weight must never exceed the GVWR.

B GCWR = GROSS COMBINED WEIGHT RATING

The total allowable weight of the completely loaded vehicle and trailer, including any fuel, passengers, cargo, equipment and accessories.

C RGAWR = REAR GROSS AXLE WEIGHT RATING

This is the weight that the rear axle is capable of supporting. The load on the axle must not exceed the RGAWR. The RGAWR for each GMC vehicle is displayed on the driver's door or door-lock pillar label.

D MAX PAYLOAD

The maximum allowable weight of passengers plus cargo that the vehicle is designed to carry.

E TWR = TRAILER WEIGHT RATING

This section of the label provides the ratings for your vehicle's specific configuration.

KEY AVAILABLE ACCESSORIES



MULTIPRO AUDIO SYSTEM BY KICKER^{®1}



HARD FOLDING TONNEAU COVER



FRONT-ROW PREMIUM ALL-WEATHER FLOOR LINERS



HIGH-CLEARANCE OFF-ROAD ASSIST STEPS



CONSOLE MOUNTED SAFE



22" MULTI-SPOKE WHEELS² IN HIGH-GLOSS BLACK

SIERRA 2500 HD

SIERRA 3500 HD

**SCAN
TO SEE
ALL**

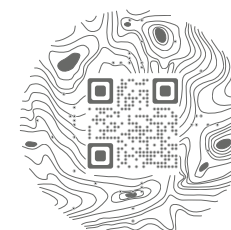
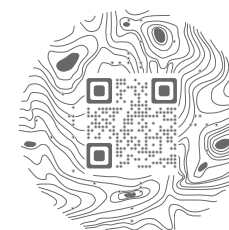

¹Non-GM warranty. Limited warranty by KICKER[®], 3 years/36,000 miles, whichever comes first. For more information, contact your dealer. ²Use only GM-approved tire and wheel combinations. See gmc.com/accessories for important tire and wheel information, or see your dealer. ©2024 General Motors. All rights reserved. The marks appearing here are the trademarks or service marks of GM, its subsidiaries, affiliates or licensors.