

'73 FORD WAGONS

FORD, TORINO AND PINTO WAGONS AND RECREATIONAL VEHICLES

WAGONMASTER

U.S.

1

1973 FORD WAGONS

BETTER IDEAS THAT MAKE FORD WAGONS NO.1 YEAR AFTER YEAR

Here's America's leading wagon family . . . 10 models in all. Big Ford, including the LTD Country Squire, Galaxie 500 Country Sedan, Custom 500 Ranch Wagon (each with 6-passenger and Dual Facing Rear Seat models) . . . the mid-size Torino line with the Gran Torino Squire, Gran Torino, Torino . . . and the subcompact Pinto.

A family of wagons with features, styling, interior room, quiet, riding comfort, convenience and customized items not found on even more expensive wagons.

Innovative Wagon Features. Ford originated the 3-Way Magic Doorgate on Fords and Torinos for extra convenient loading and unloading of people and packages. Pinto's handy counterbalanced liftgate opens wide for easy access to the cargo area. Unique Dual Facing Rear Seat Ford models and optional rear facing third seat in most Torino models give eight-passenger room. You'll also find a big, usable and lockable stowage space under the deck in all Torino and Ford wagons. For an extra measure of convenient handling, front disc brakes are standard on all wagons, power on Ford and Torino.

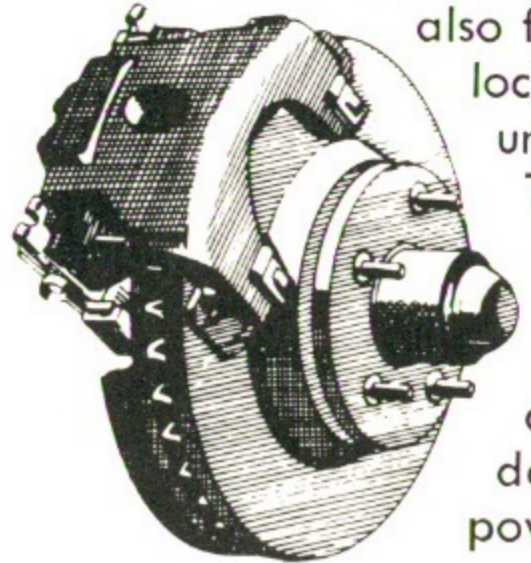

Ride. Ford wagons have a reputation for their passenger-car riding qualities. On its 121-inch wheelbase and new frame, the big Ford gives a smooth, quiet limousine-like ride. Frame and body are separated by rubber body mounts that reduce road shock and vibration. Torino's mid-size 118-inch wheelbase, body-frame construction, stable rear suspension and noise-quieting insulation package give it a solid, quiet ride. The subcompact Pinto Wagon provides an unusually quiet and comfortable ride.

Safety. To help protect you and your passengers, Ford Motor Company Lifeguard Design Safety Features are built into all Ford wagons. There are Steel Guard Rails in all side doors.

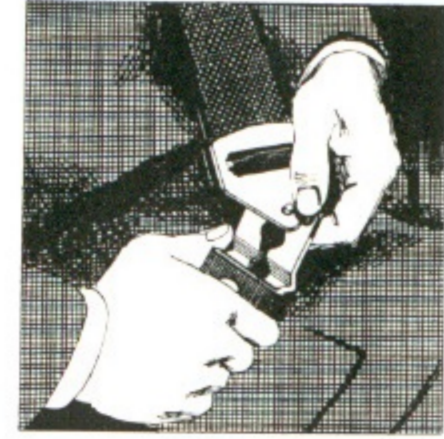
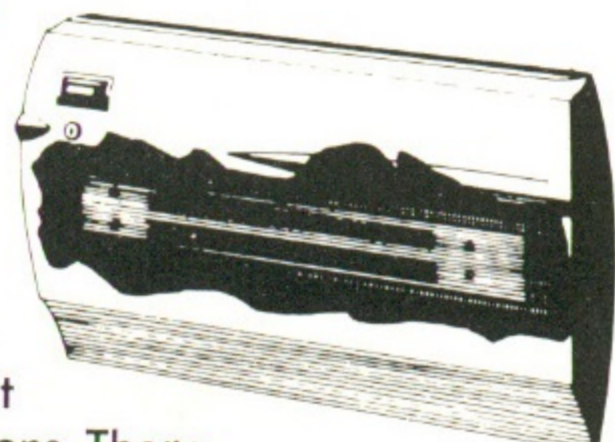

There's a dual hydraulic brake system with warning light. One-snap Uni-Lock shoulder/lap belts with a reminder system, and more. Your '73 Ford, Torino and Pinto have an Energy Absorbing Bumper System that meets 1973 Federal Safety Standards.

A complete listing of all Ford's Lifeguard Safety Features is on the back cover.

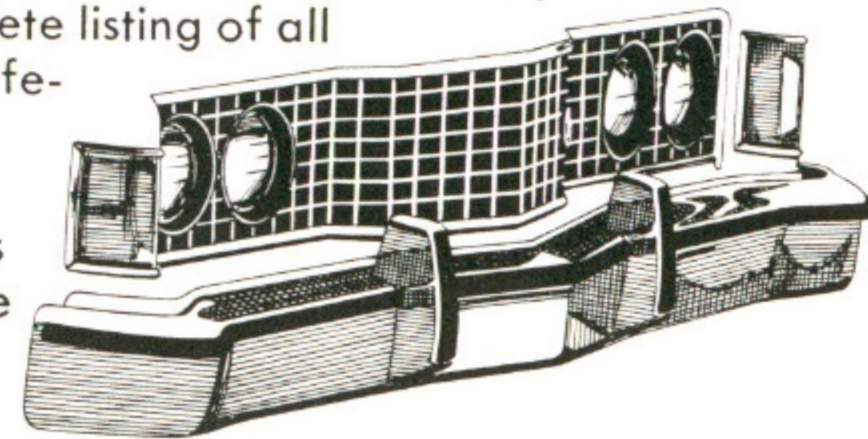

Economy of Maintenance and Operation.

Each '73 Ford, Torino and Pinto wagon calls for 36,000 miles, or 3 years, between major chassis lubrications, 4,000 miles between oil changes (or 4 months), oil filter change interval at the first 4,000 miles (or 4 months) and thereafter at 8000-mile intervals. Other service-savers include self-adjusting brakes, zinc-coated underbody parts, aluminized muffler, and more. A six-step paint process of primers and Diamond Lustre Enamel for less maintenance. And all Ford engines run on regular gas.*

You Can Tailor Each Wagon. Innovative Ford engineers give you a great opportunity to tailor your wagon to suit your special driving needs.

Steel-Belted Radial Ply Tires, a new option, have been tested to give the average driver 40,000 miles of tread life under normal driving conditions. Steel-Belted Radials also are included in a new Squire Brougham Option available on LTD Country Squire Wagons. Many other better ideas in added comfort, convenience and appearance are listed in the Option Section of each Wagon line.



Listening better. Building better. That's Ford.

*All 1973 Ford engines are designed to operate on regular gasoline with an octane rating of at least 91 (Research Method) when adjusted to factory recommended specifications.



FORD LTD COUNTRY SQUIRE

The popular leader of Ford's wagon family. One of the best reasons why Ford wagons continue to be America's No. 1 choice. Pillared hardtop styling with LTD luxury touches. 1973 newness that's highlighted with a new grille and front end treatment. The famous Squire woodgrain trim on sides and tailgate. Quiet, smooth ride with a new insulation package that puts more sound-deadening materials between passengers and the engine and the road.

The 3-Way Magic Doorgate opens like a door with the window up or down or swings down as a tailgate for easy loading and additional loadspace. With the second seat folded down there's 96.2 cu. ft. of cargo area. (See page 7 for other interior dimensions.) Get eight-passenger seating with the Dual Facing Rear Seat model.

Inside there are woodtone accents in the door panels, instrument panel and on the steering wheel. All big Ford wagons boast a new instrument panel specially designed for more driver and passenger convenience. There's also a super-size glove box this year—more than twice the volume over last year. A new inside hood release has been added for anti-theft protection. The glove compartment light and rear cargo light are standard. And, for added convenience, the windshield washer jets are mounted on the wiper arms. Even the washer reservoir is larger.

Beneath the rear floor on 6-passenger models there's 9.1 cu. ft. of lockable stowage . . . 5.4 cu. ft. on Dual Facing Rear Seat models. Rear quarter panel tops have a depressed area that's handy for storing small items.

A new spare tire extractor is standard on all big Ford wagons. Just a simple pull and the tire is raised from the tire well on to the load floor.

Standard Country Squire interiors are in all-vinyl with distinctive rectangular buttons, deep, sewn-in pleats and leather-like grain texture.

Along with the 351 CID 2V V-8, big Ford wagons also have as standard the 3-speed Select-Shift Cruise-O-Matic transmission, power steering and power front disc brakes.

Other Country Squire standards include: power ventilation, seat belt reminder system, electric clock, color-keyed loop pile carpeting, dual note horn, wheel covers. See page 7 for full list of standard features and specifications.

New options for '73 include the Power Mini-vent and Side Windows, a practical, quiet venting arrangement that opens and closes at the touch of a switch. And a powerful new 460 CID 4V V-8 Engine. You'll find many more options on pages 8 and 9.

Elegant Country Squire Standard Interior. Shown in Dual Facing Rear Seat model (cutaway view) with comfortable seating for eight (Color FR). This is all-vinyl with deep, sewn-in pleats and a rich leather-like grain texture that gives easy-chair feel. Also shown is Ford's Recreation Table with magnetized checkers, a new option that adds even more fun on trips.



Options Illustrated: Squire Brougham Option, including Steel-Belted Radial Ply White Side-wall Tires, Appearance Protection Group, Convenience Group, Deluxe Cargo Area, Deluxe Wheel Covers, Deluxe Luggage Rack, Front Cornering Lamps, Deluxe Bumper Group, Vinyl Insert Bodyside Moldings, Recreation Table.

3-Way Magic Doorgate. Pioneered by the Wagonmaster. Opens like a door with the window up . . . or with the window down. Swings down as a tailgate to give an additional two feet of load floor.



For your convenience, each illustration is color coded, example: (Color 4B). Your Ford Dealer will be pleased to show you a color chip and actual swatches of vinyl roof and interior trim materials.



The stylish Ford LTD Country Squire (Color 4B).



Family favorite Country Sedan available in 6- or 8-Passenger Models (Color 5H).

Economical Ranch Wagon, your choice of 6- or 8-Passenger Models (Color 4S).

FORD GALAXIE 500 COUNTRY SEDAN

The Country Sedan, just a step away from the elegant Country Squire. It has its own styling and luxury touches plus the ride and quiet found in all Ford wagons.

The perfect family wagon with a pillared hardtop look. Bright moldings, integral parking lamps and front side marker lights all set off with the beauty of Ford's Diamond Lustre Enamel all around.

Inside there's a new all-vinyl interior. Seat inserts have a leather-like grain texture and are sewn in a deep pleat design. Woodtone applique highlights the instrument panel and the front and rear door trim panels. Standard features include the 351 CID 2V V-8, SelectShift Cruise-O-Matic, Power Steering, and Power Front Disc Brakes.

STANDARD FEATURES:

Ranch Wagon. Mechanical—351 CID 2V V-8 Engine • 3-Speed SelectShift Cruise-O-Matic Transmission • Power Steering • Power Front Disc Brakes • Windshield Washer Jets on Wiper Arms • Energy Absorbing Bumper System • 3-Way Magic Doorgate • Power Tailgate Window. **Appearance and Comfort**—Argent Painted Grille • Integral Parking Lamps and Front Side Marker Lights • Wheel Lip Moldings • Black Sidewall Bias Belted Tires • Bright Hub Caps • Bright Drip Moldings • Dual Separated Rear Side Marker Lights • Sound Package • Dome Light • Front Ash Tray Light • Cigar Lighter • Two Rear Seat Ash Trays • Full Length Armrests • All-Vinyl Trim • Color-Keyed Loop Pile Nylon Carpet • Uni-Lock Shoulder/Lap Belts with Reminder System • Power Ventilation • New Bin-type Glove Compartment • Inside Hood Release • Steering Column Lock • Reversible Keys, "Keyless" Locking • Below Deck Lockable Storage • Spare Tire Extractor • 96.2 cu. ft. Loadspace with Second Seat Down • Ford Motor Company Lifeguard Design Safety Features listed on page 22.

Country Sedan. All of the above with these differences: **Mechanical**—Dual Note Horn. **Appearance and Comfort**—Galaxie 500 Sound Package • Woodtone Highlights on Instrument Panel and Front and Rear Door Trim Panels. Galaxie 500 Interior. Bright Bodyside Moldings • Hood Rear Molding • Chrome-Plated Grille with Unique Crest • Bright Belt Moldings.

Country Squire. All items listed above with these differences: **Appearance and Comfort**—Woodgrain Bodyside and

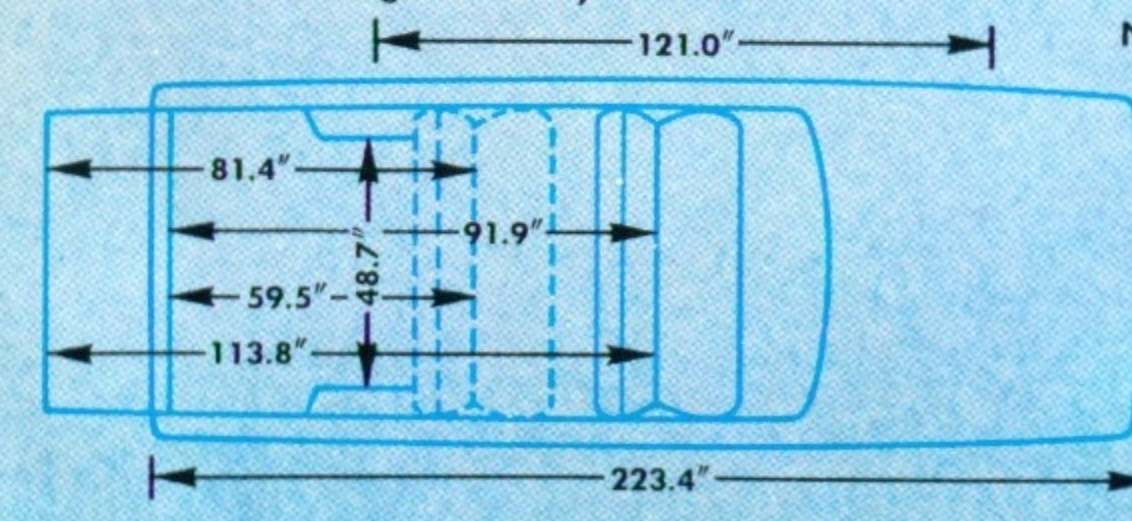

FORD CUSTOM 500 RANCH WAGON

The big Ford's economy station wagon. With the size, room and ride of the Country Squire... plus styling, comfort and luxury appointments all its own. Check the pillared hardtop design, integral parking lamps and front side marker lights, dual separated rear side marker lights, bright moldings and distinctive new grille treatment.

Slide inside. Relax in an easy-to-clean all-vinyl interior with a "basketweave" design in the seat inserts. For performance, the Ranch Wagon has as standard the 351 CID 2V V-8, SelectShift Cruise-O-Matic, Power Steering, and Power Front Disc Brakes.

And, like all big Ford wagons, this economy beauty handles 4' x 8' sheets of paneling flat with the second seat down.

Tailgate Trim • Unique LTD Grille Treatment and Integral Parking Lamps and Front Side Marker Lights • Full Woodtone Applique on Instrument Panel • Deluxe 2-Spoke Steering Wheel • LTD Luxury All-Vinyl Interior • Bright Pedal Pads • New LTD Sound Package • Electric Clock • Glove Box and Cargo Lamps • Wheel Covers.
Options Illustrated: Vinyl Roof, White Sidewall Tires, Deluxe Luggage Rack, Wheel Covers, Vinyl Insert Bodyside Moldings, Convenience Group (Country Sedan—detailed on page 8), Deluxe Bumper Group.
Specifications: Wheelbase 121"; Length Overall 223.4"; Width Overall 79.9"; Height Overall 57.1"; Front Tread 64.1"; Rear Tread 64.3"; Fuel Tank 21 gal. (regular fuel), Approx. Curb. Weights—Country Squire 4851*, Country Sedan 4790*, Ranch Wagon 4759*. *For Dual Facing Rear Seats add 50 lb.



Spare Tire Extractor. Standard on all Ford wagons. With practically an effortless pull the tire is raised onto the load floor from the side well for easy handling.

Note: See Color Code reference on page 3.

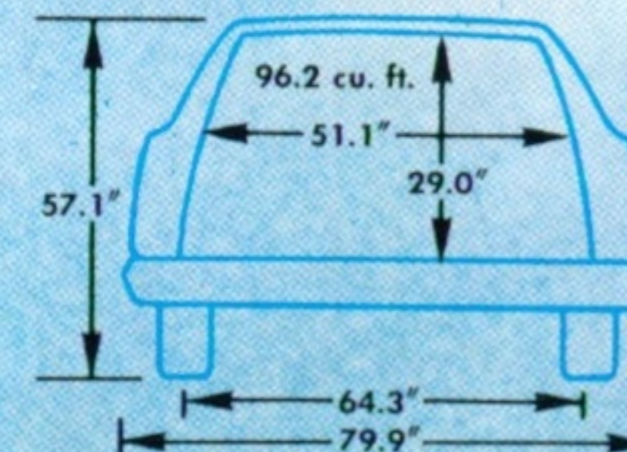

Country Sedan Pleated All-Vinyl Interior (Color EF).

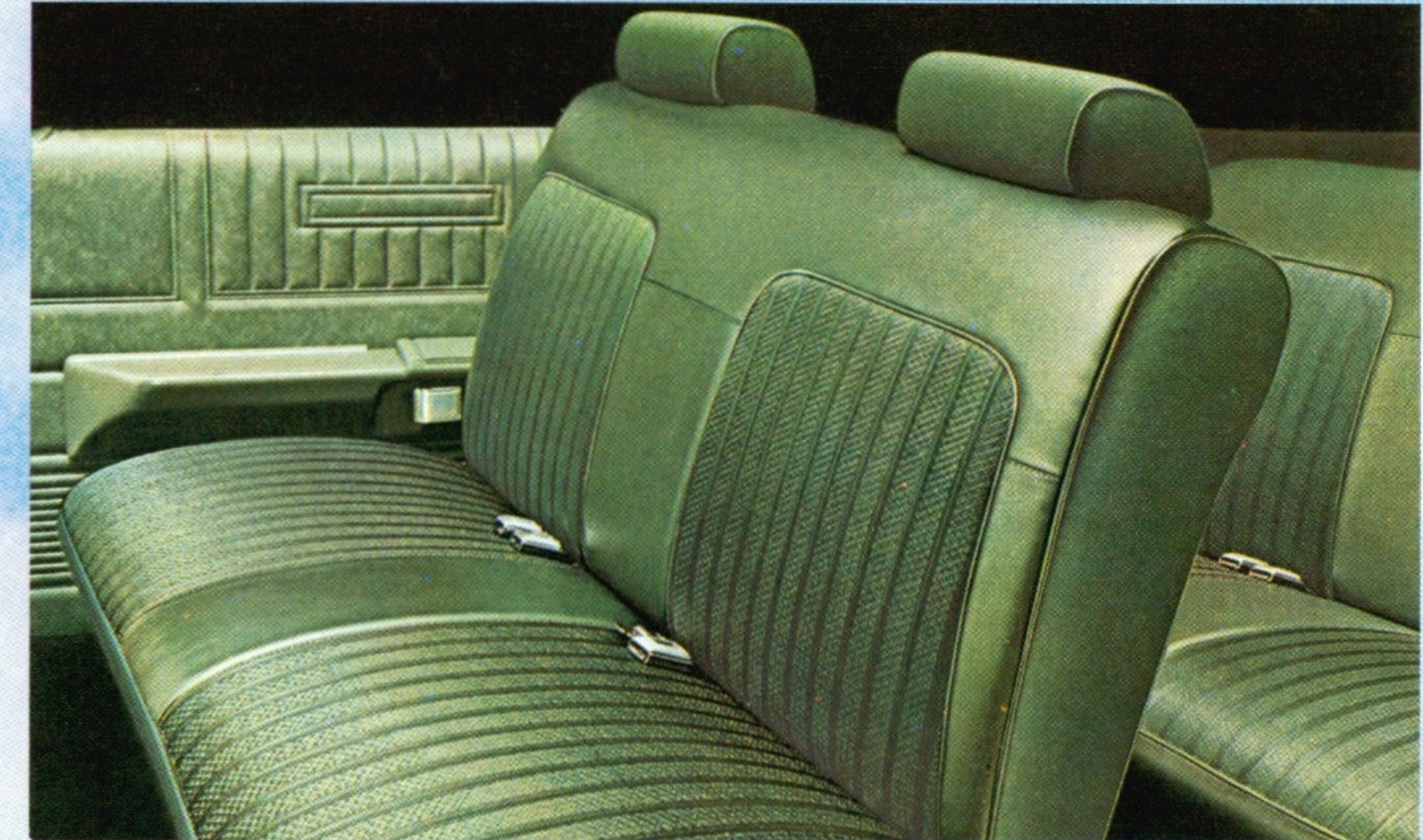

Ranch Wagon All-Vinyl Interior with "basketweave" inserts (Color BR).



Power Front Disc Brakes. These brakes use same principle as the most modern jet aircraft. Dissipate heat fast, are fade-resistant and less affected by water. Standard on all Ford wagons.

Lockable Below Deck Storage. Ford wagons have handy, lockable under-the-deck storage, 6-passenger models with 9.1 cu. ft. of space. Dual Facing Rear Seat models with 5.4 cu. ft. of locked storage area.



The Super Size Glove Compartment. A big 1973 Ford feature, the bin-type glove box. Volume is an amazing 676 cu. in.—over twice that of previous years. Has new twist-open lock.



FORD WAGON BETTER IDEA OPTIONS

The Wagonmaster makes wagon owning that much nicer with Better Idea options you can select to fit your needs. Remember, all Ford wagons have the big 351 CID 2V V-8 engine, SelectShift Cruise-O-Matic, power front disc brakes, power steering, 3-Way Magic Doorgate and power tailgate window standard.

So start from there to build your own kind of wagon...



Lockable Side Stowage Compartment/Carpeted Cargo Area. Side stowage compartment in quarter panel with lock and woodtone-trimmed carpet for cargo area.

Deluxe Cargo Area (shown above). Items above plus padded quarter trim panels with carpeting on lower portion.



Dual Facing Rear Seat Models. Exclusive with Ford Motor Company. Seating space for two. Seats fold down quickly to convert to cargo area.

Electric Power Door Locks. Lock or unlock all doors, including the tailgate from the driver's seat. **Electric Power Tailgate Lock** is available as a separate option.

Recreation Table. A desk, snack table, game board. Has magnetized checkers and holders for cups, odds and ends. Stores under seat or in lockable side stowage compartment.

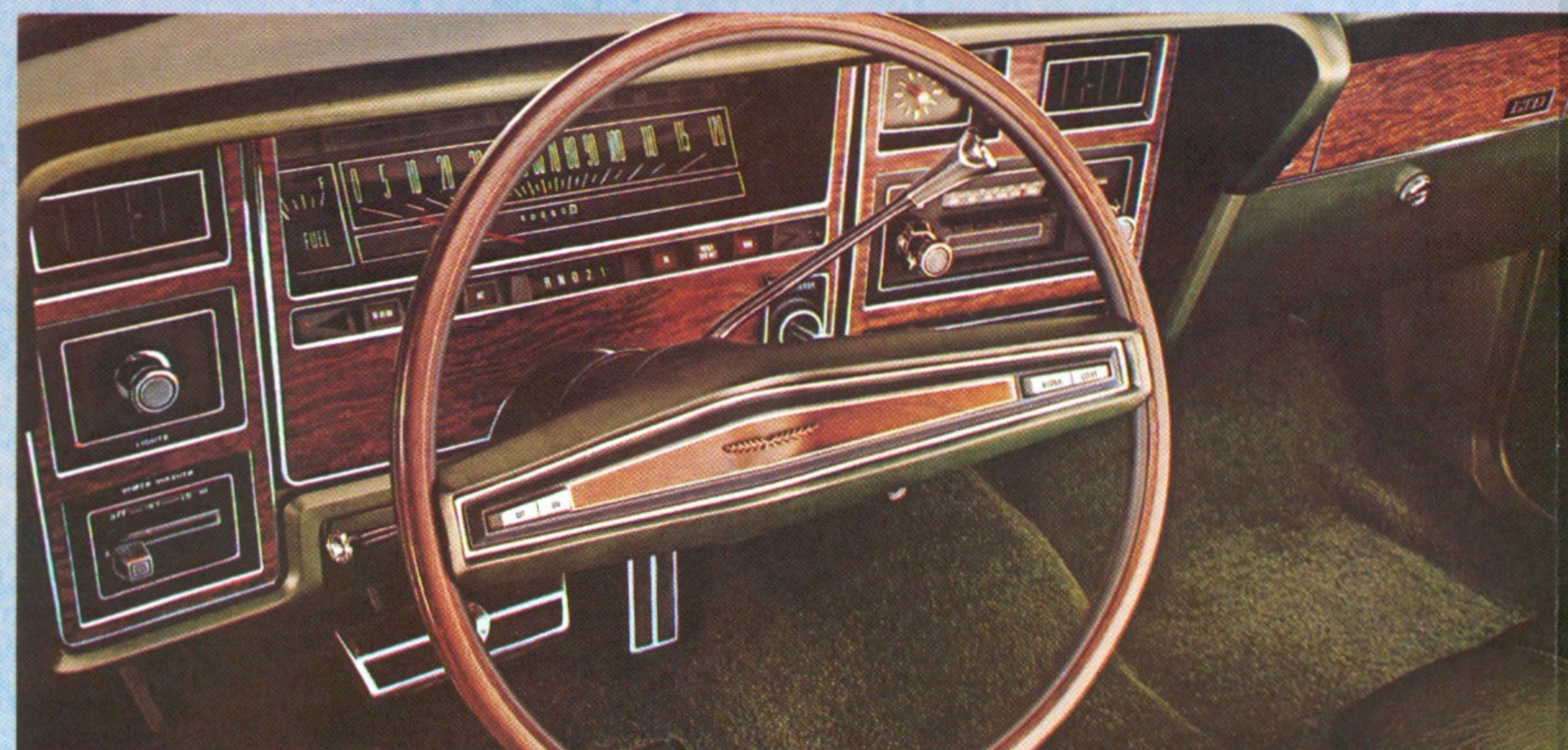
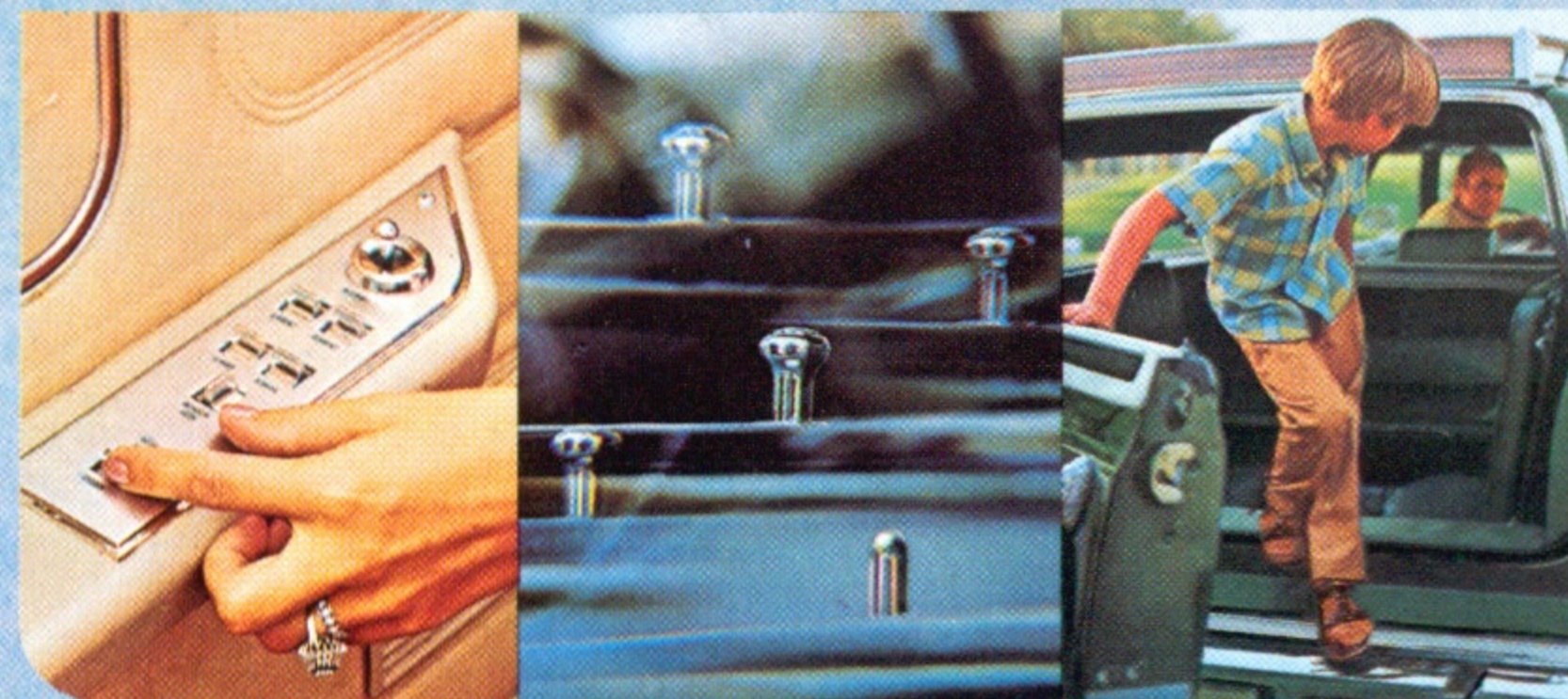

Radio/Tape Selections. Pick AM. Or surround yourself with the rich sound of AM/FM stereo. Two front-door-mounted speakers and dual rear speakers. And, a new sound system, AM/FM Stereo Radio with Tape Player.

SelectAir Conditioner. Year-round cooling/heating with the SelectAir Conditioner with Automatic Temperature Control that you set once and forget. Also available with manual temperature control.

Fingertip Speed Control. Ideal for turnpike travel. Just set speed and take your foot off the accelerator. Cruise relaxed. Includes **Deluxe 2-Spoke Rim-Blow Steering Wheel** which has pressure-sensitive ring that lets you sound horn wherever your hands are placed on the wheel.

Anti-Theft Alarm System. New protection from car thieves. When either front door is locked with the ignition key an electronic sensing device is armed. Anyone opening a door or tailgate without the use of the key sets off the system and the horn blows. Includes a lockable inside hood release and Spare Tire Lock.

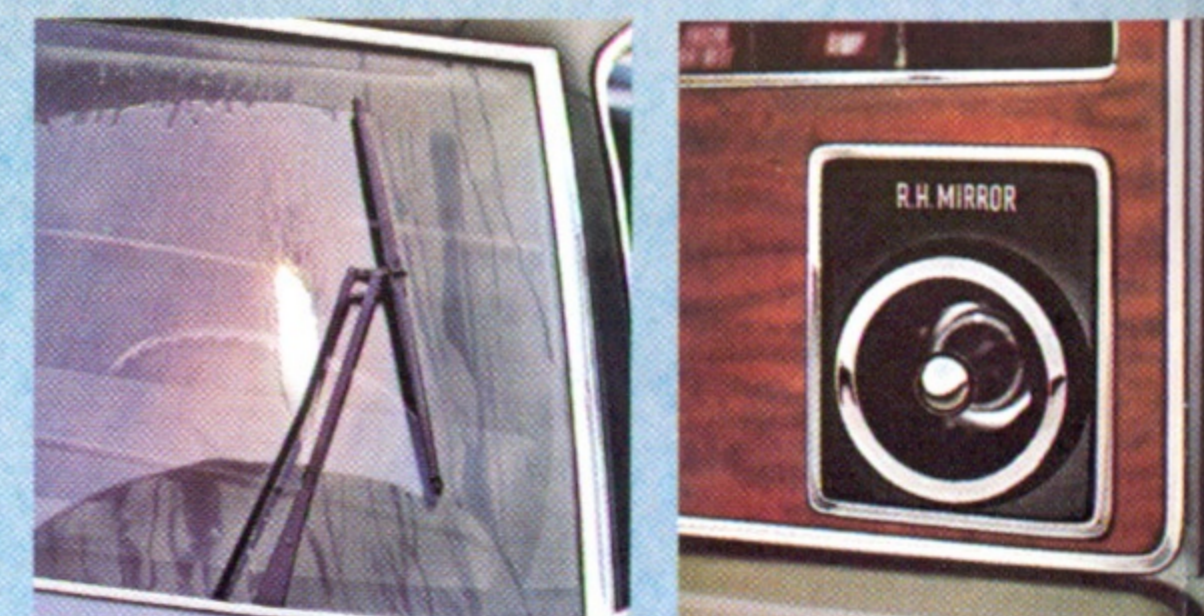

Convenience Group. Includes Remote Control Left Hand and Right Hand Mirrors—adjustable from driver's seat; Automatic Parking Brake Release; Interval Windshield Wipers—let you regulate pause between sweeps from 2 to 10 seconds to handle light rainfall; Visor Vanity Mirror; and Auxiliary Ash Tray in right front armrest. Also shown: new standard wiper-mounted washer jets that direct fluid precisely where needed.

Squire Brougham Option. The ultimate in station wagon comfort and elegance. High Back split bench seat with manual passenger recliner. Special Brougham vinyl interior trim with leather-like grain texture. Cut-pile carpeting. Auxiliary ash tray in right front armrest, front door courtesy lamps, and rear door courtesy light switches. Steel-Belted Radial Ply Tires.



Trailer Towing Packages. Here's the 1973 offering of towing packages from the Wagonmaster. **Class I**—Up to 2000-lb. gross trailer weight, 200-lb. tongue load. Includes removable ball, tongue and wiring harness. **Class II**—Up to 3500-lb. gross trailer weight, 500-lb. tongue load. Includes heavy-duty suspension, trailer cooling package (heavy-duty radiator with larger transmission oil cooler in radiator), trailer towing wiring harness and trailer towing decal. **Class III**—6000-lb. gross trailer weight, 700-lb. tongue load. Includes higher axle ratio, heavy-duty suspension, alternator 70 amp. minimum, 80-amp. battery, trailer towing decal, wiring harness, cooling package (described above), coolant recovery system, 6 1/2 inch wheels, heavy-duty frame.

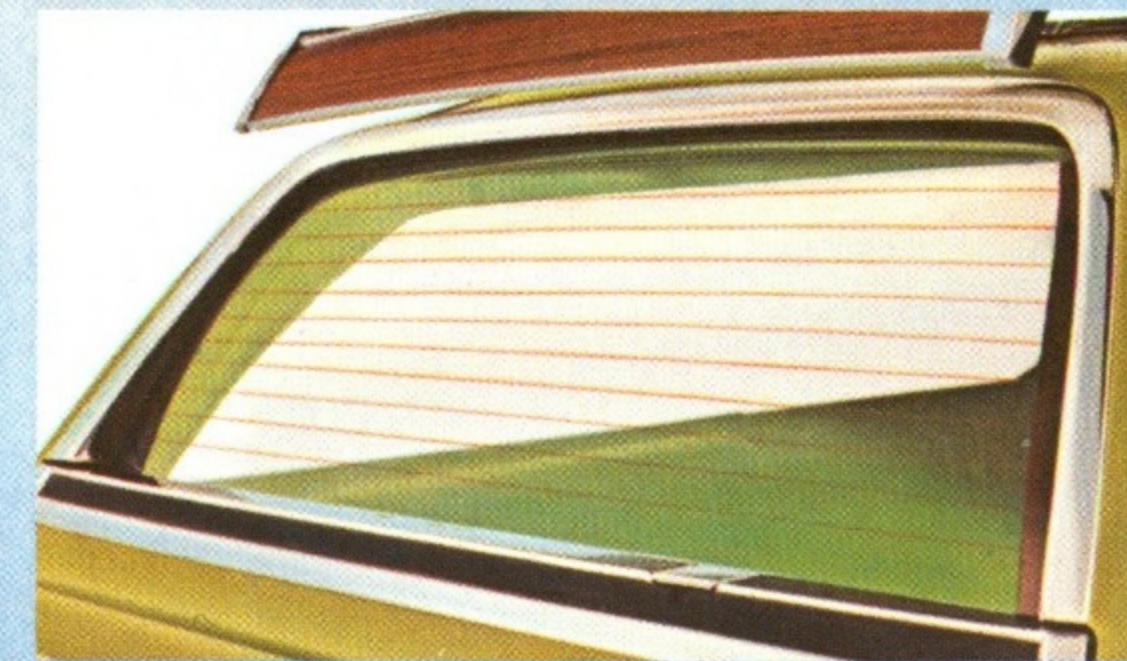

Electric Rear Window Defroster. Clears doorgate window electrically. Melts ice and snow. Includes tinted rear window and 70-amp. alternator.



Tailgate Window Washer. Window is washed and wiped clean by lowering into tailgate with switch then pushing switch "in" to activate washer. Window is washed in tailgate, wiped clean as it comes up. Helps rear visibility for increased driving safety.



Power Mini-Vent and Side Windows. Driver can operate Mini-Vents on his and passenger side. Or passenger can operate his own.

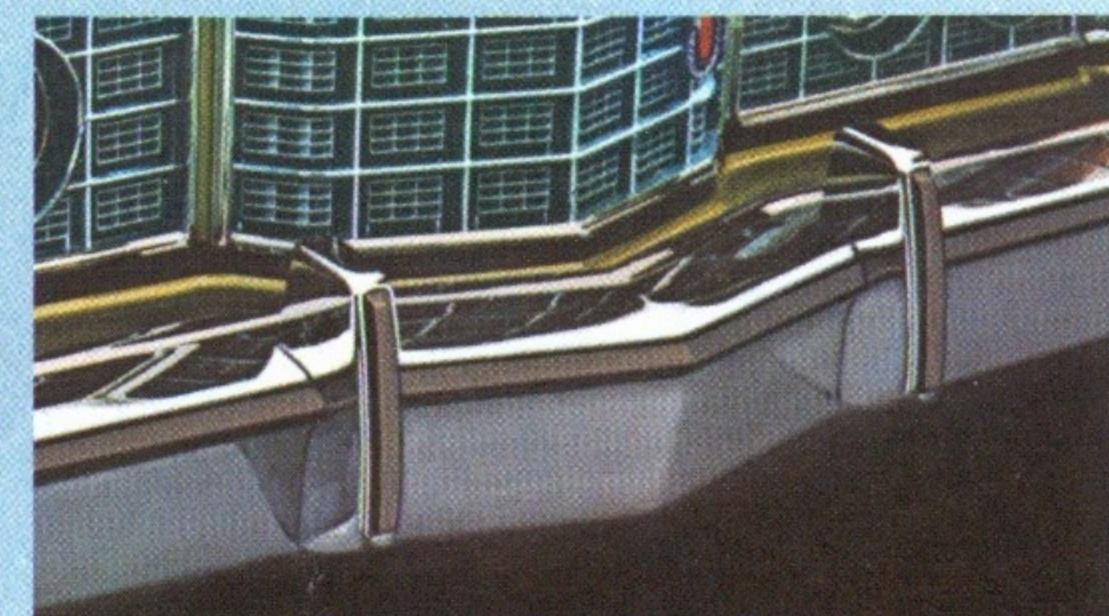

Deluxe Bumper Group. Front and Rear Bumper Guards with rubber inserts and horizontal rub strip on front bumpers. Includes an integral rear rubber step on wagons to make entering and exiting easier. Combined with the standard Energy Absorbing Bumper System, the bumper guards can help increase front and rear end protection. **Front and Rear Bumper Guards** are also available.



Deluxe Luggage Rack. Includes integral rear window air deflector, woodgrain applique and adjustable rear cross bar for small or large loads.

Automatic Load Adjuster. An air shock absorber system that automatically maintains the level of the wagon under heavy loads. You always ride level.



Steel-Belted Radial Ply Tires, available for every Ford model, have been tested to give the average driver 40,000 miles of tread life under normal driving conditions.

Appearance Protection Group. Includes door edge guards, spare tire lock, color-keyed floor mats with carpet inserts and license plate frames.

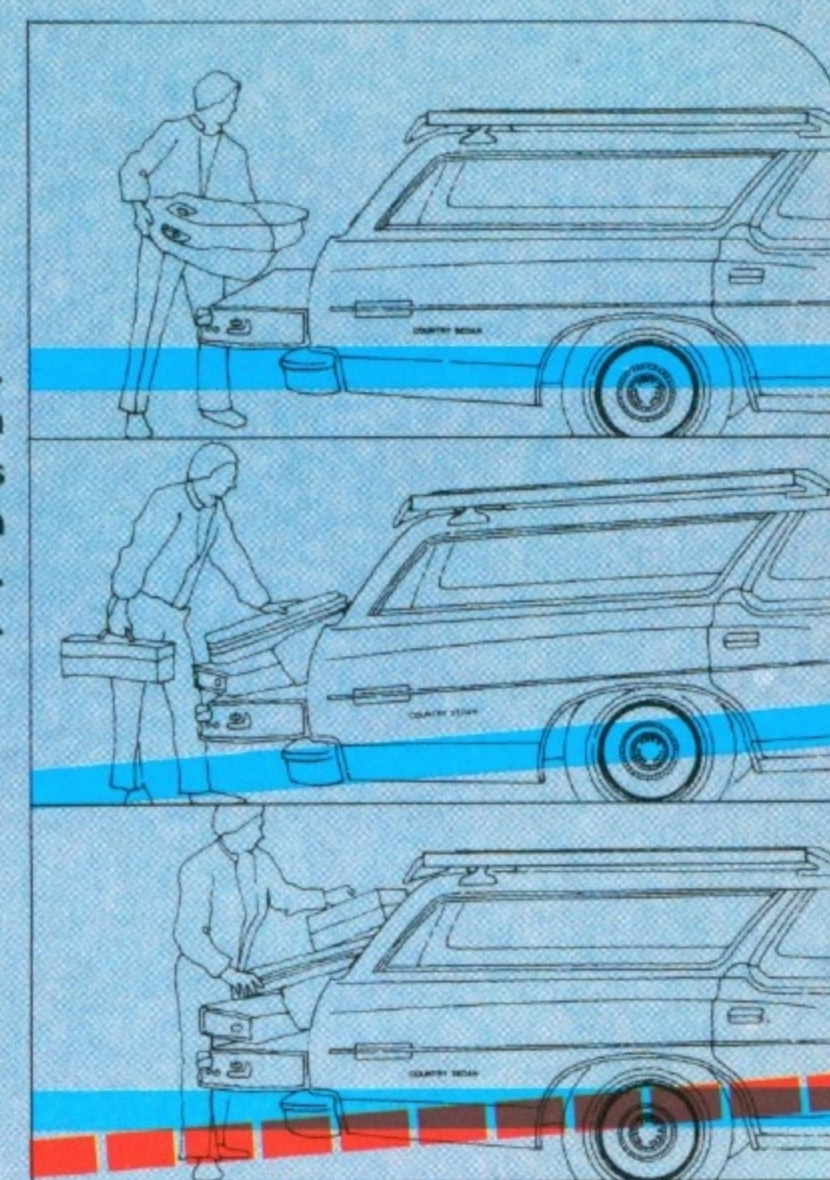

Wheel Covers. Increase the luxury look for your wagon. Standard on Country Squire.

Deluxe Wheel Covers. High fashion. Improve the exterior appearance. Distinctive.

OTHER OPTIONS:

Optional Ratio Axle, Traction-Lok Differential Axle, Heavy-Duty 80-amp. Battery (standard with 429 and 460 CID 4V and Class III Trailer Towing package), **Deluxe Color-Keyed Shoulder/Lap Belts, Electric Clock, Tinted Glass, Outside Left Hand Remote Control Mirror, Light Group** (includes: instrument panel, cargo area, glove box, engine compartment, rear door courtesy light switches, parking brake warning light, engine compartment light), **Vinyl Insert Bodyside Moldings, Rocker Panel Moldings, Tutone Roof Paint, Dual Accent Bodyside Paint Stripes, Metallic Glow Paint, 6-Way Driver only Power Seat, 6-Way Full-Width Power Seat, Vinyl Roof, Dual Rear Seat Speakers, Rim-Blow Deluxe 3-Spoke Steering Wheel, Heavy-Duty Suspension.**

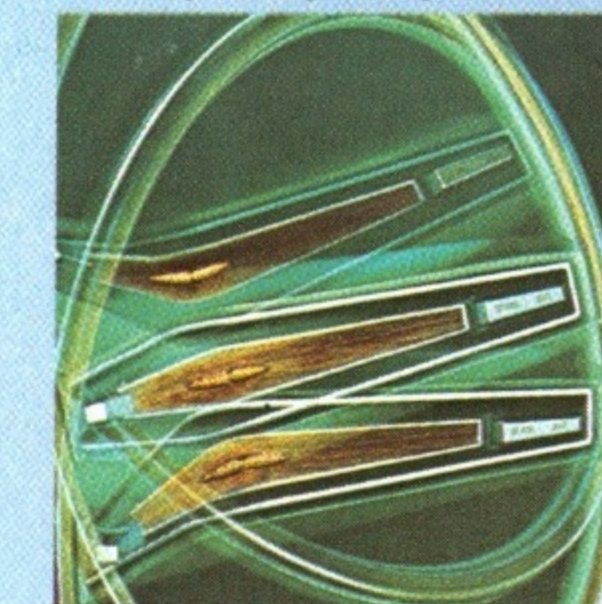

Engine Options. Your 1973 Ford wagon can be also equipped with extra power to suit your driving requirements. **400 CID 2V V-8.** Includes 70-amp. heavy-duty battery. **429 CID 4V V-8.** Includes 80-amp. heavy-duty battery. **460 CID 4V V-8.** Includes 80-amp. heavy-duty battery.

Tilt Steering Wheel. A choice of five positions lets you relax as you drive. Makes getting in and out even easier.

FORD GRAN TORINO SQUIRE

The Gran Torino Squire is the top of the line. A solid quality-built mid-size wagon in the tradition of the Ford Country Squire. Look the Gran Torino Squire over. From the rich woodgrain trim on the sides and tailgate to its distinctive new grille and full wheel covers. No wonder it's called a Squire!

Comfortable room for six or carry eight easily with optional rear facing third seat. It's full-size comfort with the handling ease of mid-size cars.

The body-frame type construction in Torino provides a noticeably smooth, quiet ride. This is accomplished by using 16 tuned body and frame rubber mounts to help isolate the passenger compartment from road shocks. A deluxe sound insulation package makes the ride even quieter.

Now, add to this a trim mid-size 118-inch wheelbase with a wide tread and you have mid-size ride, handling and road stability at its best.

Inside, comfort and luxury are all around. Deluxe pleated vinyl trim. Touch it. Feel that leather-like texture. Durable, too. The Gran Torino Squire steering wheel and instrument panel with woodtone highlights. Bright pedal pads. And, brand new in '73 is a handy inside hood release for anti-theft protection.

There's also the exclusive 3-Way Magic Doorgate, 84.9 cu. ft. of loadspace, wide enough to lay 4' x 8' panels flat with the second seat down—over 8 cu. ft. of lockable stowage under the load floor . . . 5.9 cu. ft. with optional third seat. Get a Torino and you've got yourself quite a wagon.

In addition to those features mentioned, the Gran Torino Squire, as well as the Gran Torino Wagon and Torino Wagon, come with the 302 CID 2V V-8 engine standard. Other standard Squire features include: Power Front Disc Brakes, Heater/Defroster with DirectAir Ventilation, concealed windshield wipers, seat belt reminder system, Stabul rear suspension, and an Energy Absorbing Bumper System. See page 13 for a complete list of standard features.

Options Illustrated: Steel-Belted Radial Ply White Sidewall Tires, Appearance Protection Group, Deluxe Wheel Covers, Deluxe Luggage Rack, Front Bumper Guards. (See pages 14 and 15 for other options available.)

Spacious Gran Torino Squire Interior with Deluxe Pleated Vinyl Trim (Color GB).



For your convenience, each illustration is color coded, example: (Color 9A). Your Ford Dealer will be pleased to show you a color chip and actual swatches of vinyl roof and interior trim materials.

3-Way Magic Doorgate. Opens like a door with window up . . . or with the window down. Swings down as a tailgate to add extra length to cargo area.



Gran Torino Squire: New Grille, New Features, New Fashions (Color 9A).



Torino... Mid-size Economy with a Family Flair (Color 4B).

Gran Torino... Good Looks... Great Features... Great Ride (Color 5M).

FORD GRAN TORINO WAGON

There's a lot of wagon on this mid-size frame. Six-passenger room, ride, handling—all wrapped up at an attractive price. The good looks that you get with the Squire are apparent in the Gran Torino. The gleam of paint, styling that's refined in '73 with new front end treatment and the high-style grille design of the Squire. Concealed windshield wipers. Wheel lip moldings and bright touches around the headlamps. Standard Power Front Disc Brakes and 302 CID 2V V-8 engine.

Like the Squire, the Torino body/frame construction with 16 tuned body and frame rubber mounts help isolate the passenger compartment from road shocks. A deluxe sound insulation package increases the riding pleasure.

Loading or unloading is a snap with the convenient 3-Way Magic Doorgate. There's a big 84.9 cu. ft. of loadspace. Even lay 4' x 8' sheets of building material flat.

And with the Gran Torino Squire and Gran Torino wagons, you can add the Rear Facing Third Seat for extra seating. (See page 14.)

The Gran Torino has a new durable all-vinyl pleated interior. A leather-grain look with a plush feel. Four colors are offered: Black, Medium Blue, Medium Green and Ginger.

STANDARD FEATURES:

Ford Torino Wagon. Mechanical—302 CID 2V V-8 Engine • Power Front Disc Brakes • 3-Speed Fully Synchronized Manual Transmission • Energy Absorbing Bumper System • Black Sidewall Tires • 3-Way Magic Doorgate • Direct Air Ventilation • Heater-Defroster.

Appearance and Comfort—Bright Drip Moldings • Hub Caps • Bright Moldings at Quarter Windows and Tailgate Window • Floor Mats • Reversible Keys, "Keyless" Locking • Uni-Lock Shoulder/Lap Belts with Reminder System • Inside Hood Release • Steering Column Lock • Below Deck Lockable Stowage • Tailgate Belt Molding • Ford Motor Company Lifeguard Design Safety Features listed on page 22.

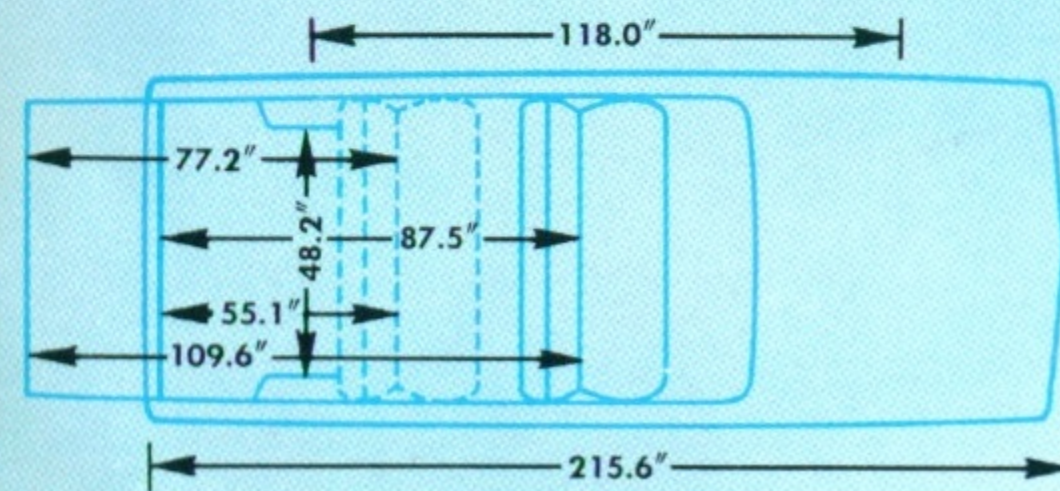

FORD TORINO WAGON

The lowest-priced Torino wagon that doesn't economize on features, ride, handling, road stability or style. Solidly built with body/frame construction and sporting its own distinctive grille and front end treatment, it's the Torino tradition with an economy price tag.

Standard features include: bright drip, quarter window and tailgate window moldings. 3-Way Magic Doorgate, power front disc brakes and the 302 CID 2V V-8.

And for 1973, there's a new all-vinyl interior that's easy to clean, comfortable to sit in and long on looks. Pick from Black, Medium Blue or Medium Green.

Ford Gran Torino Wagon. All features at left with these differences: **Appearance and Comfort**—Unique Grille • Bright Treatment at Headlamp Area • Lower Bodyside Molding • Wheel Lip Molding • Pleated All-Vinyl Interior Trim • Color-Keyed Carpets • Deluxe Sound Insulation Package • Concealed Windshield Wipers.

Ford Gran Torino Squire. All of the above with these differences: **Mechanical**—Dual Note Horn. **Appearance and Comfort**—Full Wheel Covers, Bodyside Woodgrain • Woodgrain on Tailgate • Deluxe Pleated Vinyl Interior Trim • Woodtone Insert on Steering Wheel • Bright Pedal Pads • Woodtone Instrument Panel Ornamentation and Door Trim.

Options Illustrated: White Sidewall Tires, Deluxe Bumper Group, Wheel Covers, Deluxe Luggage Rack, Vinyl Insert Bodyside Molding (on Torino Wagon).

Specifications. Wheelbase 118"; Length Overall 215.6"; Height 54.9"; Width Overall 79.0" (Gran Torino Squire), 79.0" (Torino); Front Tread 63.4"; Rear Tread 63.5"; Fuel Tank 20.5 gal. (regular fuel); Approx. Curb Weights—Gran Torino Squire 4281, Gran Torino 4253, Torino 4230.

Note: See Color Code reference on page 10.

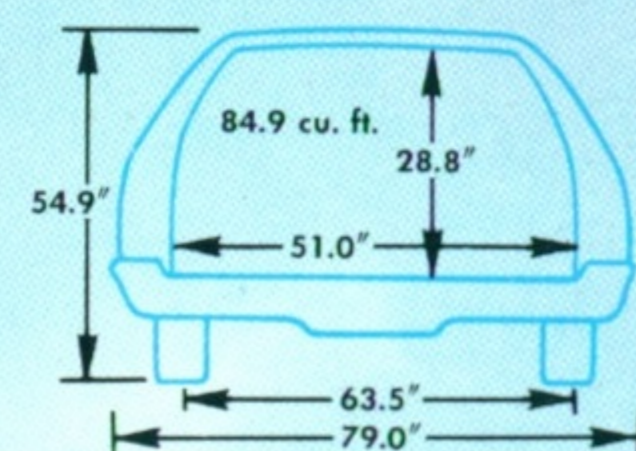

Gran Torino Wagon Interior... Smart, Durable, Pleated All-Vinyl, Leather-Grain (Color CF).

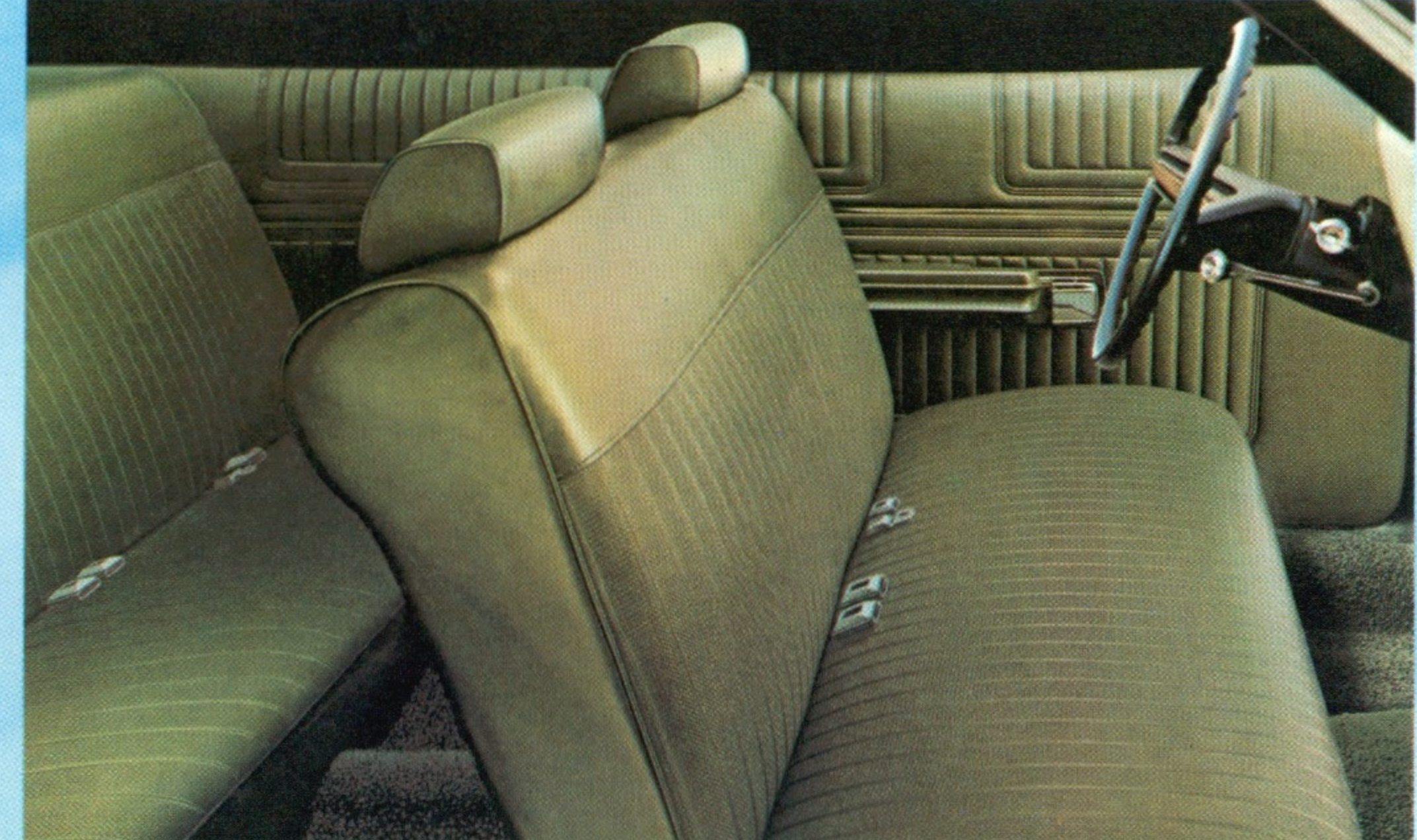

Torino Wagon Interior... New Ribbed Design, All-Vinyl (Color AR).



Power Front Disc Brakes. Standard on all Torino wagons, these brakes utilize the same principle as used on jet aircraft. They dissipate heat faster, are fade-resistant and less affected by water.

9 Feet of Loadspace. With the tailgate open and the second seat down you've got nine feet of loadspace length. Lay 4' x 8' pieces of building material flat. Pile in groceries, camping equipment, sports gear.

Lockable Below Deck Stowage. All six-passenger Torino wagons have 8.1 cu. ft. of lockable storage space under the deck. Useful for trips to stow extra luggage and keep valuables out of sight.



FORD TORINO WAGON BETTER IDEA OPTIONS

Here's your chance to pamper yourself. A big selection of options that let you personalize your new Torino Wagon to suit your driving requirements. Add convenience. Add luxury. Add performance. Have fun!

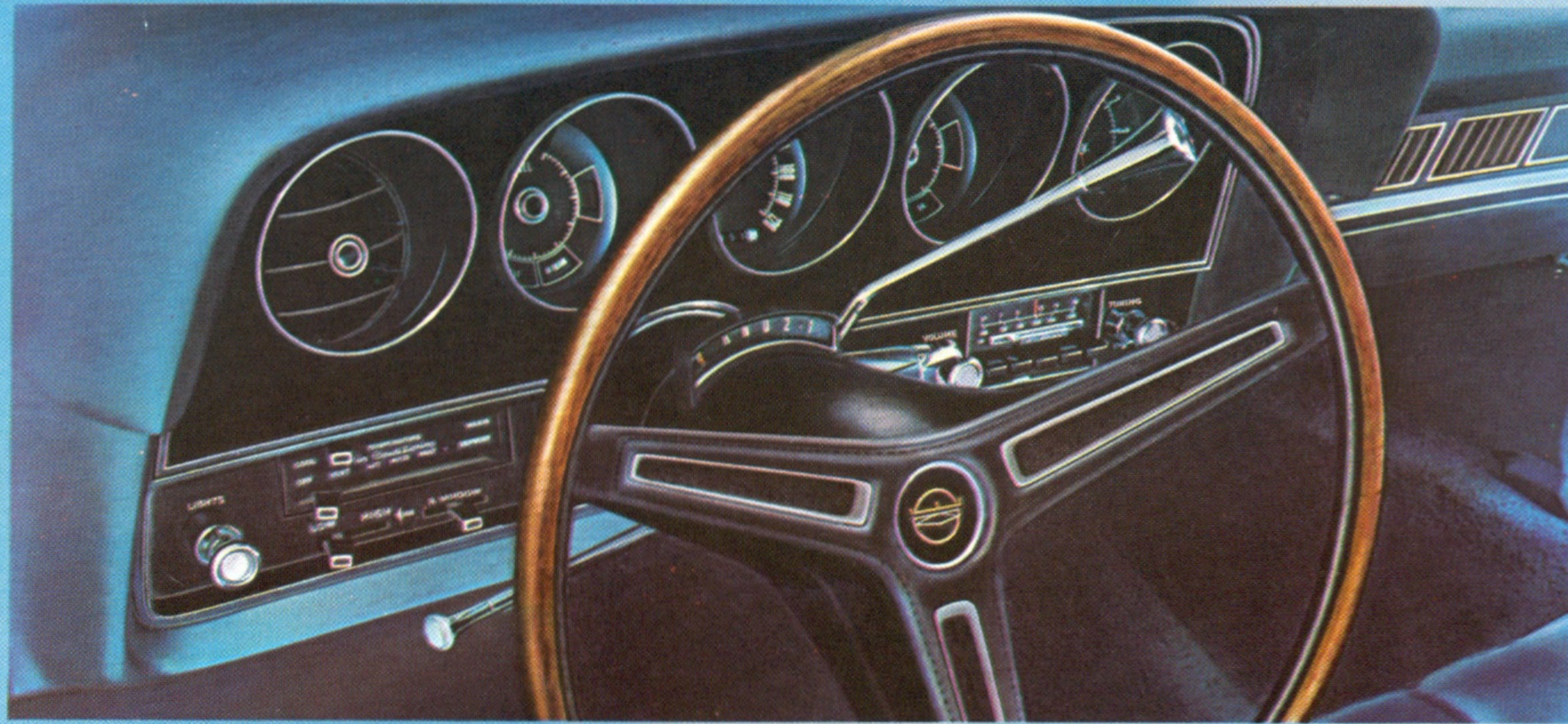

Deluxe 3-Spoke Rim-Blow Steering Wheel. A pressure sensitive ring inside the woodtone wheel rim lets you sound the horn with a gentle squeeze.

Radios. Try the AM/FM Stereo. Beautiful sound. Includes two front-door-mounted and dual rear speakers. Clear fidelity **AM Radio** also available.

SelectAire Conditioner. Provides year-round comfort. Cooling in the warm months. Heats in the winter. All from a single unit.

SelectShift Cruise-O-Matic. Ford's 3-speed automatic transmission that lets you shift manually when you want it. Great convenience.

Power Steering. Makes parking easier. Add a touch of elegance with the **Leather Wrapped Steering Wheel.** Genuine leather, actually sewn on the deluxe 2-spoke wheel, gives a better grip with handsome look.



Electric Power Door Locks. One simple control locks all four doors and doorgate from driver's seat. Handy!

Carpeted Cargo Area. For appearance and protection. Adds a richness to the cargo area. Protects the deck from scratching or marring. Can be vacuumed easily.

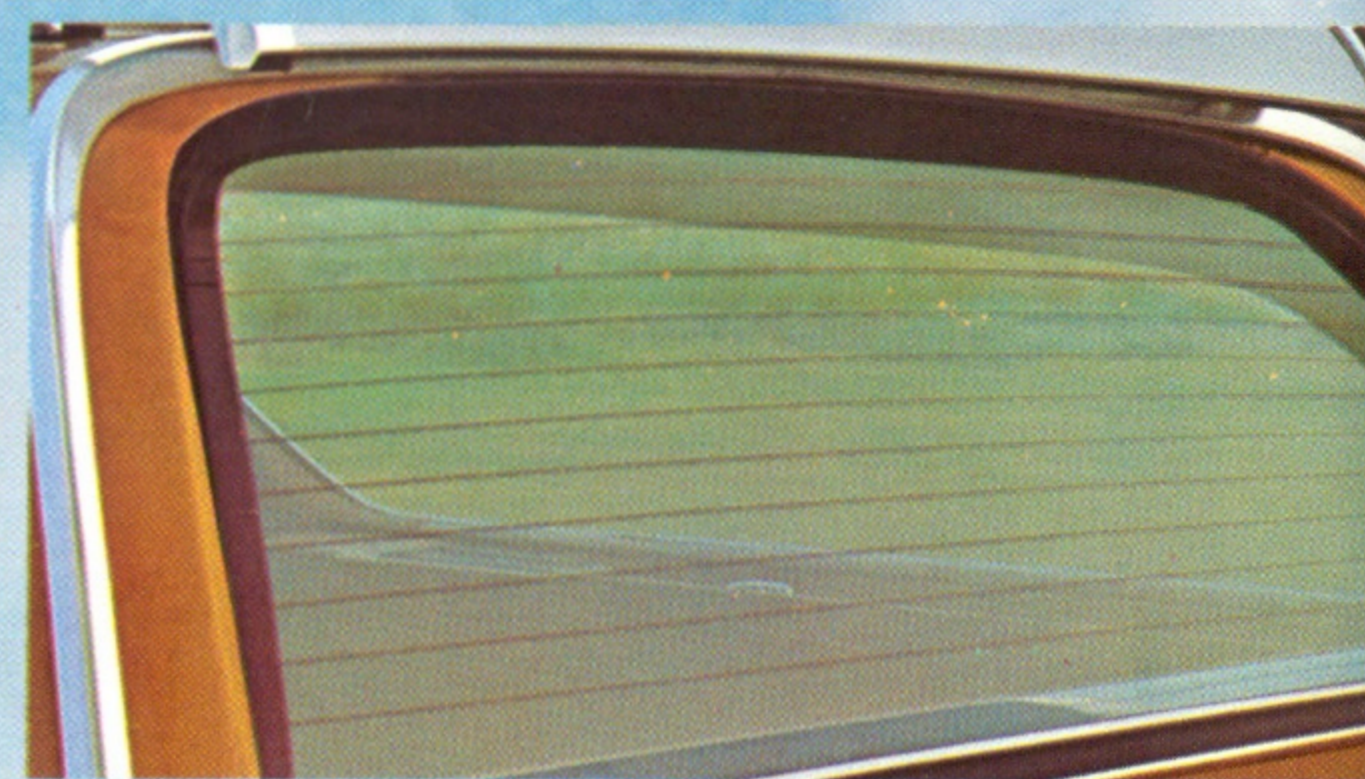
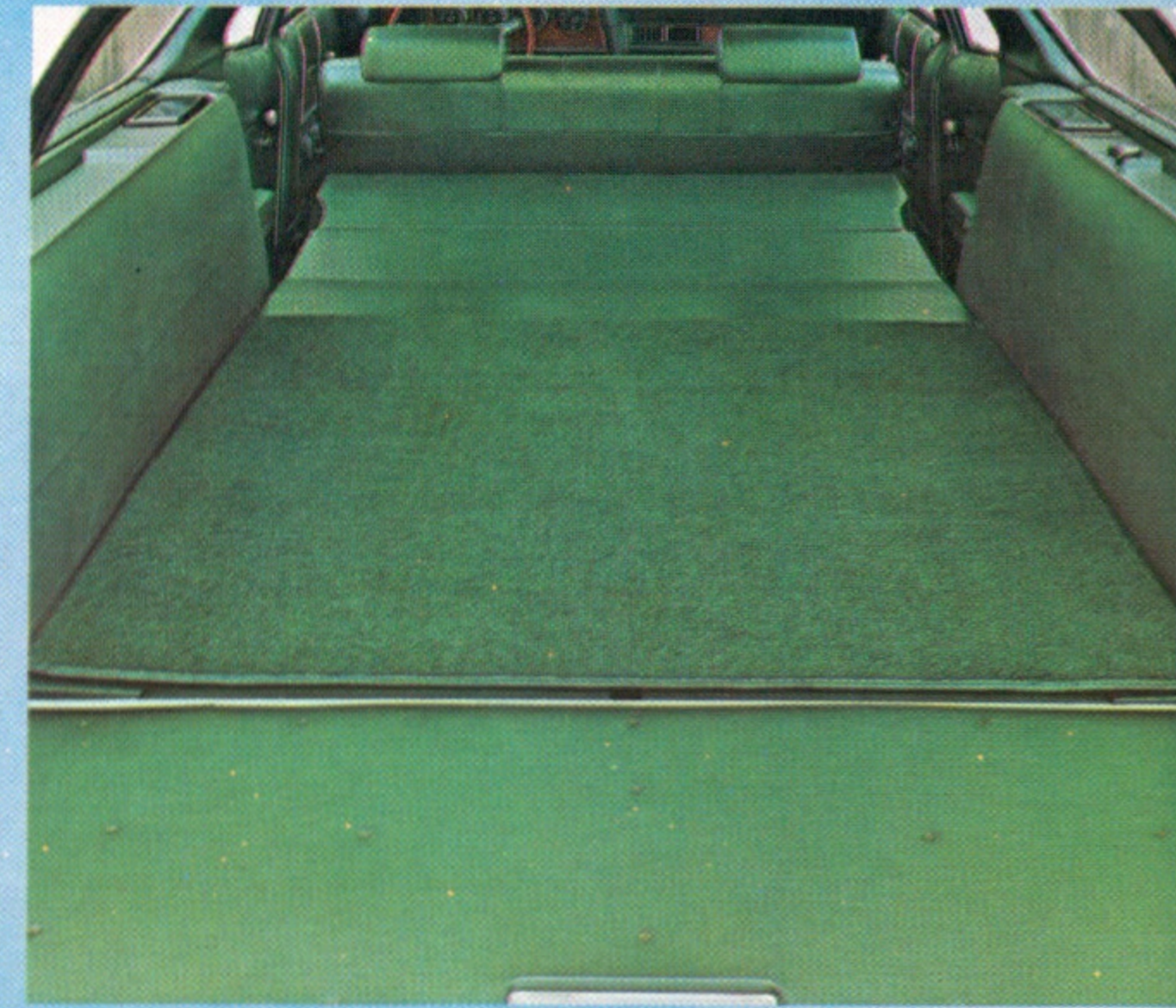

Electric Rear Window Defroster. Clears ice and snow at the touch of a switch. Heating elements are on inside surface. Window is tinted glass.

Rear Facing Third Seat. Get extra passenger room with this addition. When folded down you still have about 6 cu. ft. of lockable below deck storage. Available on Gran Torino Squire and Gran Torino.

Power Windows. Power Side Windows with Power Tailgate Window offer extra convenience. All side windows can be operated from driver's seat or individual side windows by passengers. Also includes driver-controlled "lock." **Power Tailgate Window** is offered separate.



Deluxe Luggage Rack.

Handsome addition in bright metal. Has adjustable rear cross-bar and integral rear window air deflector to help keep tailgate window clean by directing air downward.



Outside Color-Keyed Dual Racing Mirrors. Slick looking mirrors with left-hand remote controlled and right-hand manually adjustable.

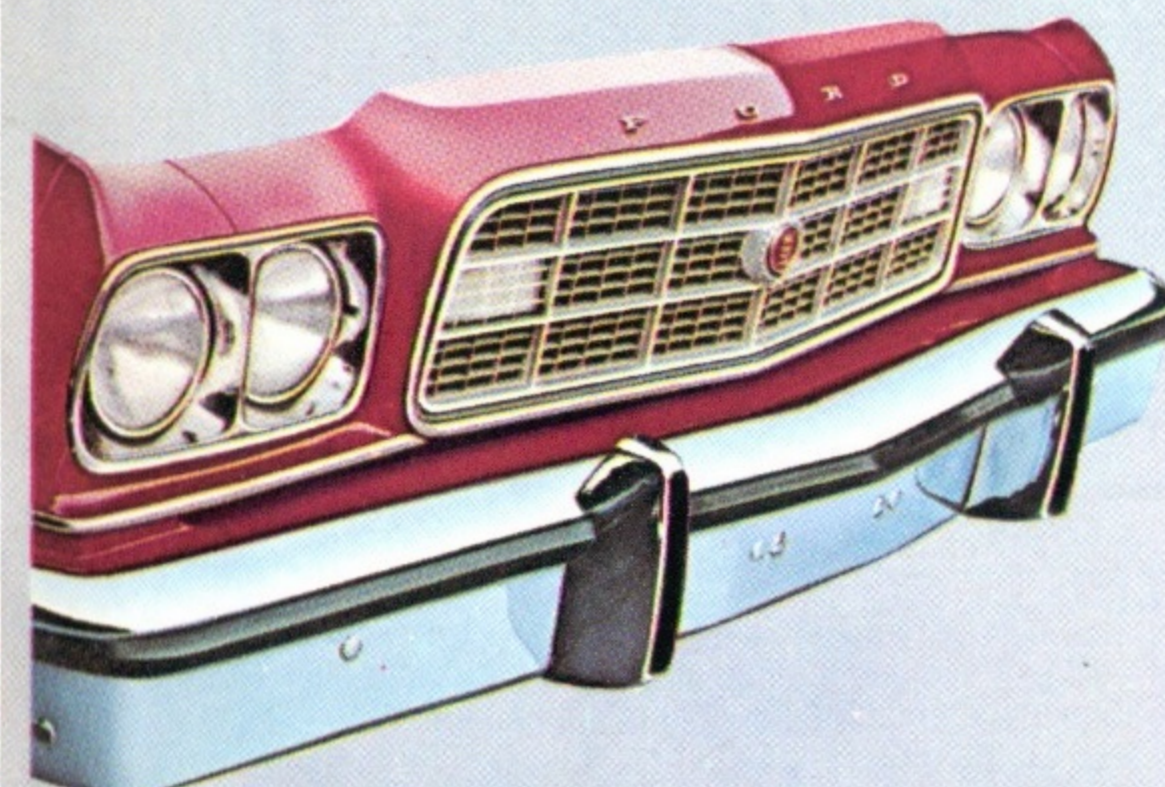

Bumper Guards. Three offerings are available: **Front Bumper Guards, Rear Bumper Guards,** and the **Deluxe Bumper Group** which includes front and rear bumper guards and a full-width front rub strip. With the new Energy Absorbing Bumper System, these offer added protection.

Trailer Towing Packages. **Class II**—up to 3500-lb. gross trailer weight, 500-lb. tongue load. Includes heavy-duty load suspension, extra-cooling package, 3.25 axle ratio, wiring harness and trailer towing decal. **Class III**—up to 6000-lb. gross trailer weight, 700-lb. tongue load. Includes heavy-duty alternator, heavy-duty suspension, wiring harness, 3.25 axle ratio, extra-cooling package, coolant recovery system and trailer towing decal.

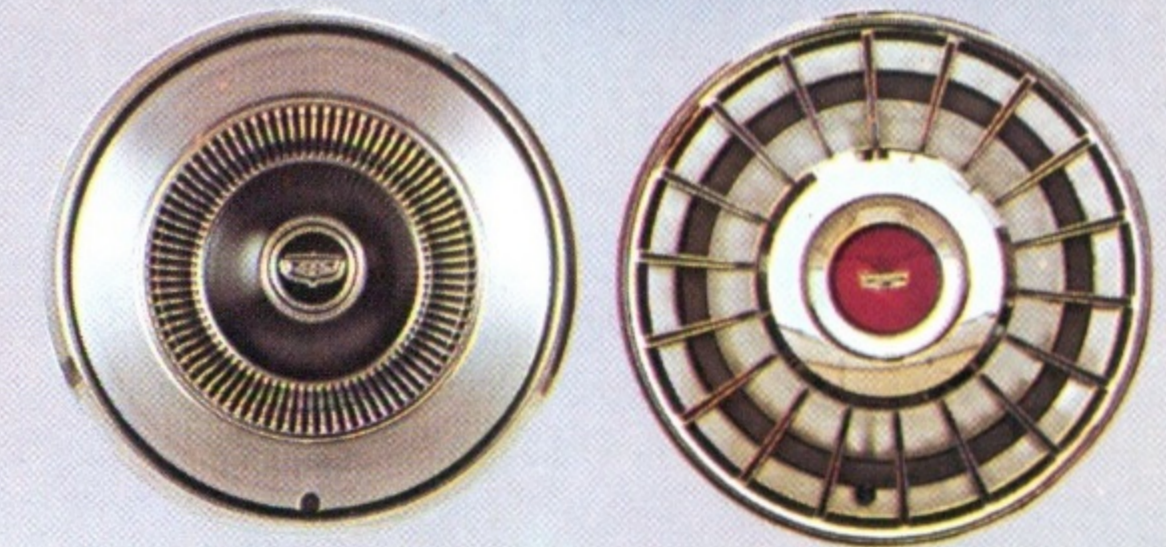

Wheel Covers. Two styles are available. **Regular Wheel Covers** have a shining metal surface surrounding a unique hub design with crest. The **Deluxe Wheel Covers** have raised fins with black inserts to enhance the wheel area.

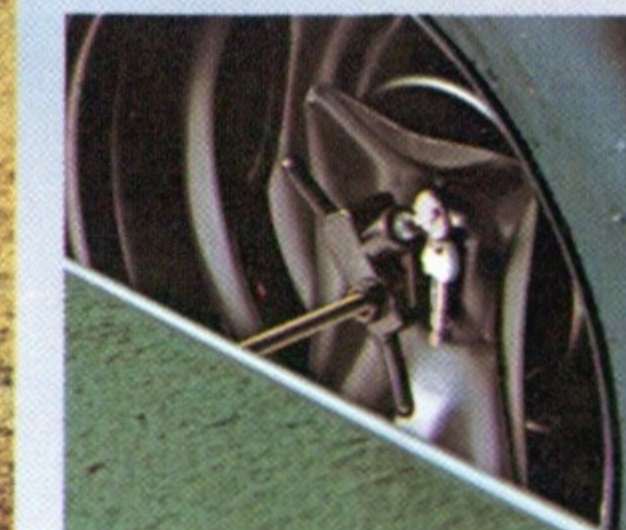

Appearance Protection Group. Protect your new Torino from nicks, scratches, mars, fire thieves. Door edge guards, color-keyed front floor mats, front and rear license plate frames, and spare tire lock are included.

Tires. Steel-Belted Radial Ply Tires are available for every Torino wagon. They have been tested to give the average driver 40,000 miles of tread life under normal driving conditions.



OTHER OPTIONS:

Accent Group with deluxe passenger compartment carpeting and full wheel lip moldings (Torino only). **Optional Ratio Axle. Traction-Lok Differential Axle, Heavy-Duty Battery**—73 amp., **Deluxe Seat and Shoulder Belts, Electric Clock, Tinted Glass. Instrumentation Group** including tachometer, trip odometer, engine gauges and electric clock, **Vinyl Insert Bodyside Moldings, Dual Rear Seat Speakers, Heavy-Duty Suspension, Metallic Glow Paints, 6-Way Full Width Power Seat.**

Engines. For extra power and performance in your Torino Wagon consider these engine choices.

351 CID 2V V-8	400 CID 2V V-8
	429 CID 4V V-8

FORD PINTO WAGON

Back to the basics in wagons. With years of experience in building small cars and station wagons, we've put the best of all our skills and know-how into the stylish subcompact 4-passenger Pinto Wagon. We've even added an option to add a dash of Squire luxury to the basic wagon.

Here's what it has going for itself . . . good looks, the basic economy and practical all-around versatility heritage started by the 2-door and Runabout and almost 10 inches more length for more passenger and cargo room . . . an easy-to-open liftgate provides

rear entrance to over 60 cu. ft. of cargo space (almost six feet long with second seat folded down) . . . rack-and-pinion steering (handles smoothly, turns quickly in a short 31.5 ft. circle, parks handily) . . . standard 2000-cc. engine and front disc brakes . . . wide track stability (holds the road well) . . . rear flipper window . . . fold-down rear seat . . . carpeting in the passenger and cargo areas . . . extra strength parts—and the Squire Option with exclusive woodgrain on bodyside and liftgate that really marks it as one from the Wagonmaster's great family.

Standard Interior . . . smart and practical. There's a new look to the Pinto Wagon's all-vinyl standard interior for 1973 . . . a unique and attractive pin-stripe design in the seat cushion and seat backs. The front High Back bucket seats are comfort-molded with urethane foam. The one-piece rear seat folds down easily and has a thick pad and cover on its back to protect it and the cargo. See page 19 for details of the Squire Option interior and exterior features.



All-vinyl standard Pinto Wagon Interior (Color: AF).

STANDARD FEATURES:

Mechanical—2000-cc. 4-cylinder 2V 122 CID Engine • Full-Sync 4-Speed Manual Floor Shift with Hand-Matched Gears • Manual Self-Adjusting Front Disc Brakes • Front Bumper Guards • Energy Absorbing Bumper System • Extra Strength Parts (starter motor, ball and universal joints, rear wheel bearings) • Rack-and-Pinion Steering • Side Markers • Parking Lamps • A78 x 13 Black Sidewall Tires • DirectAir Ventilation • 3-Speed Heater • Six-step Paint Process. **Appearance and Comfort**—Bright Windshield Molding • Bright Side Window Molding • Bright Belt Moldings • Full Length Liftgate with Fixed Window • Bright Liftgate Molding • Flipper Rear Quarter Windows • Color-Keyed Floor and Cargo Area Carpets • All-Vinyl Interior • Illuminated Wiper/Washer and Climate Controls • Rearview Mirror • Uni-Lock Shoulder/Lap Belts • plus all Ford Motor Company Lifeguard Design Safety Features listed on page 22.

Specifications. Pinto Wagon: Wheelbase 94.2"; Fuel Tank 12 gal. (regular gas); Approx. Curb Weight—2490 lb.



Easy-loading Pinto Wagon Cargo Area almost 6 ft. long with second seat down (Color: AF).

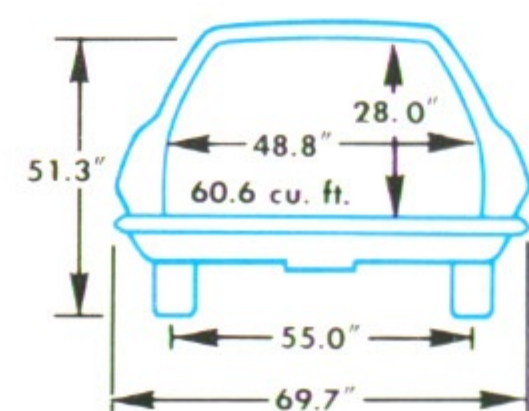
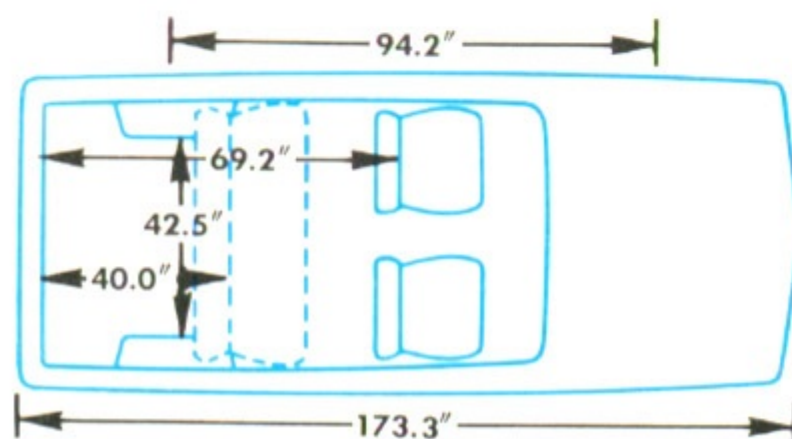

Options Illustrated: Accent Group (Pinto Wagon. See page 18 for details). Deluxe Bumper Group, Vinyl Insert Bodyside Molding (shown with Squire Option), Squire Option (see page 19 for details). Roof Luggage Rack, White Sidewall Tires (both Wagons).



Pinto Wagon with Elegant Squire Option and the Sports Accent Group in Dark Brown Metallic (Color: 5F).

Solid, sensible, carefree Pinto Wagon with Accent Group (Color: 6E).

For your convenience, each illustration is color coded, example: (Color 6E). Your Ford Dealer will be pleased to show you a color chip and actual swatches of vinyl roof and interior trim materials.

FORD PINTO WAGON BETTER IDEA OPTIONS

With Pinto you can go plain or fancy. There are appearance, convenience, comfort and protection options you can choose to make your riding and driving just that much nicer. Browse through the following and pamper yourself.

Accent Group. Adds a little spice to owning a Pinto Wagon. Includes Vinyl Insert Bodyside Protection Molding, Wheel Lip Moldings and Wheel Covers.



Sports Accent Group. Includes all the Luxury Decor Group items (except bodyside and rocker panel moldings), Steel-Belted Radial Ply White Sidewall Tires, 25-oz. cut-pile carpeted passenger area, and five vibrant color choices: Orange, Avocado (Color 4B, above), Yellow, Saddle Bronze Metallic, and Brown. Color-keyed "super-soft" vinyl seats with cloth inserts come with Orange, Avocado and Yellow. Tan vinyl seats, with Ginger cloth inserts, come with Saddle Bronze Metallic (Color 5T), or Dark Brown Metallic (Color 5F, shown on page 17).



Air Deflector. New option, with attractive woodgrain finish, can be attached to top of rear liftgate. It redirects air flow to help keep the rear window clean for better visibility.

Luxury Decor Group. A nice put-on for your Pinto Wagon. Things both you and your passengers will appreciate. You get all the items in the Accent Group plus Rocker Panel Moldings. Inside you have all the attractions illustrated below. A selection of Deluxe Cloth or "super-soft" Pleated All-Vinyl Seat Trim with Deluxe Door Trim Panels, Cut-Pile Carpeting, Deluxe 2-Spoke Steering Wheel, Multi-Directional Vent Registers, Cigar Lighter, Rear Seat Ash Tray, Passenger Side Courtesy Light Switch, Woodtone Applique on Instrument Panel and Quarter Trim Panel, Bright Parking Brake with Woodtone Grip and Color-Keyed Boot, Shift Lever with Woodtone Accents and Deluxe Uni-Lock Shoulder/Lap Belts.

OTHER OPTIONS
SelectAire Conditioner,
Tinted Glass, Heavy-Duty
Battery—54 amp., Door
Edge Guards, Front Color-
Keyed Floor Mats with
Carpeted Inserts, Vinyl
Insert Bodyside Molding,
Rocker Panel Molding,
Starter Interlock, Radios
(AM/FM stereo, AM/FM
monaural and AM),
Metallic Glow Paints.

Squire Option. A beautiful complement to the Pinto Wagon, and a Ford Wagonmaster innovation. Exterior includes Wheel Covers, Woodgrain on Bodysides and Liftgate. Inside there's a choice of Deluxe Cloth or Pleated Vinyl Seat Trim, Deluxe Door Trim Panels, Cut-Pile Carpeting, Deluxe 2-Spoke Steering Wheel, Multi-Directional Vent Registers, Cigar Lighter, Rear Seat Ash Tray, Passenger-Side Door Courtesy Light Switch, Instrument Panel and Quarter Trim Panels with Woodtone Appliques, Bright Parking Brake with Woodtone Grip and Color-Keyed Boot, Shift Lever with Woodtone Accents, Deluxe Shoulder/Lap Belts and Cargo Light.

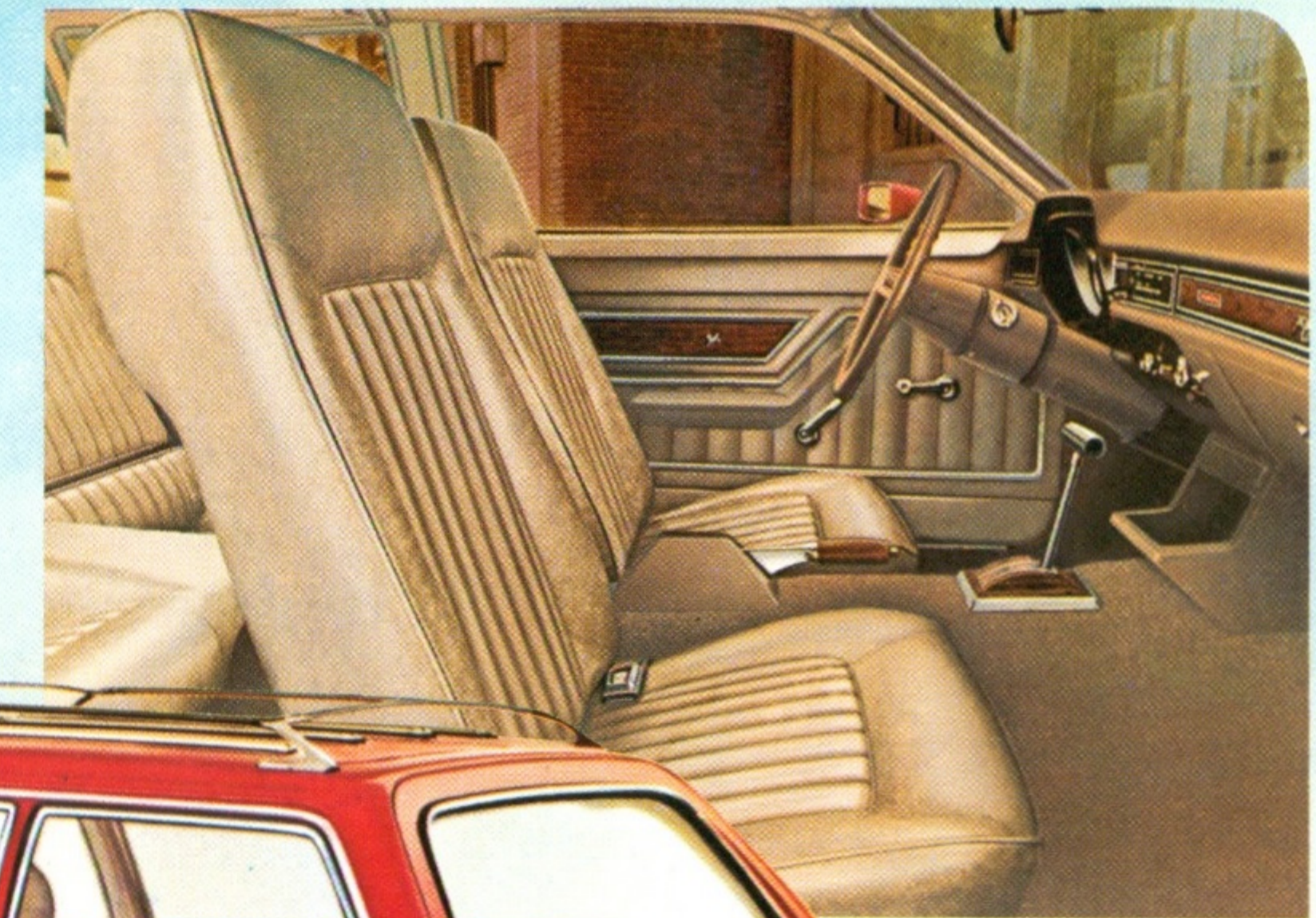

Luggage Rack. Specially designed for Pinto to add extra carrying capacity. Bright metal makes handsome luxury addition.

Note: License plate frames shown are a dealer accessory.



SelectShift Cruise-O-Matic. The proven smooth 3-speed automatic transmission that lets you shift automatically or manually. Convenient.

Electric Rear Window Defroster. Helps clear ice from rear window at the flick of a switch. Heating elements are on glass inside surface.

Convenience Group. Consists of Inside Day/Night Rearview Mirror, Outside Remote LH Color-Keyed Racing Mirror, Deluxe Shoulder/Lap Belts and Glove Box Lock.

Outside Color-Keyed Dual Racing Mirrors. In body color of your Pinto Wagon. Includes Remote LH and RH Manual Controlled Mirrors.

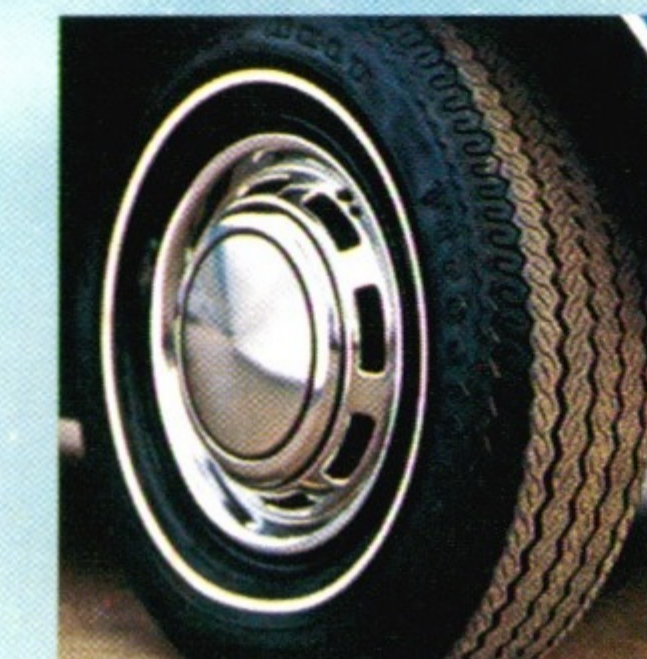

Wheel Covers. Bright-metal full wheel covers. (Std. with Accent Group, Luxury Decor Group and Squire Option.)

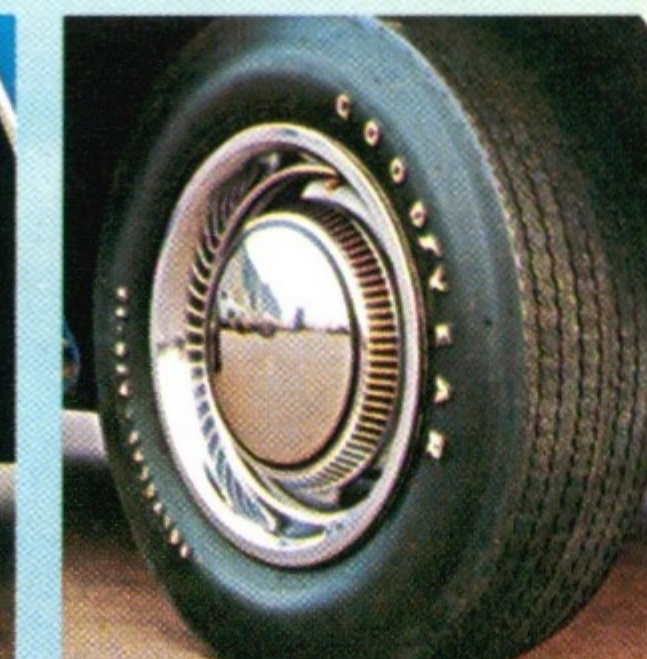

Trim Rings/Hub Caps. A popular Pinto dress-up. Adds the gleam and dash of bright metal around tires.



Forged Aluminum Wheels. Completely new, they combine lightness and strength in an attractive sporty design.

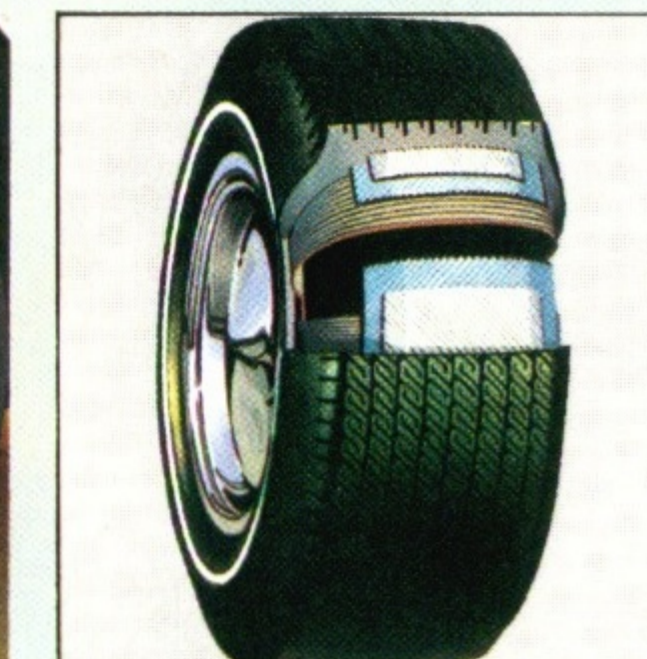

Steel-Belted Radial Ply Tires. Tested to give the average driver 40,000 miles of tread life under normal driving conditions.

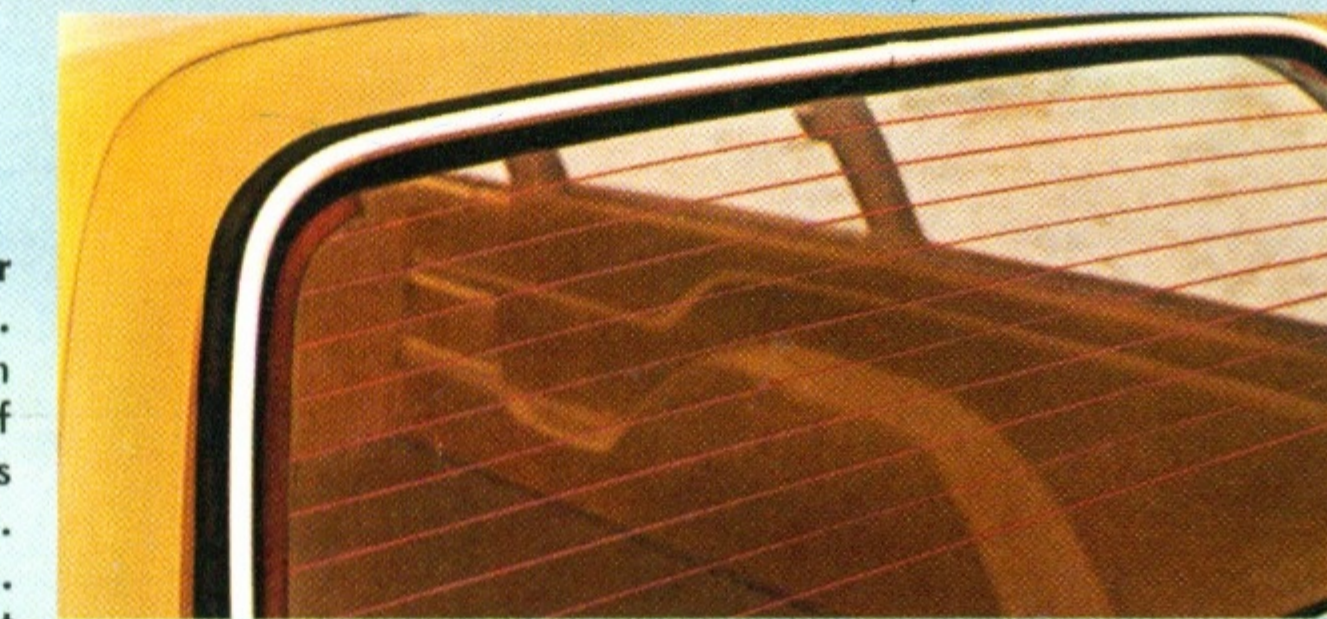

Protection Groups. Deluxe Bumper Group, Front and Rear Bumper Guards with rubber inserts and Horizontal Rub Strips on Bumpers. Protection Group includes above plus Vinyl Insert Bodyside Molding (brown with Squire Option), and Spare Tire Lock. Rear Bumper Guards, with rubber inserts on front and rear, available as a separate option.



Leather Wrapped Steering Wheel. Sports car flair of genuine leather, sewn with a fine stitch.

FORD RECREATION VEHICLES

The new generation fun fleet. That's the Wagonmaster's innovative 1973 lineup of recreation vehicles to take to the American road. New ways to enjoy the out-of-doors. New comfort. New selection of Better Idea options to make your travelling that much nicer.

F-350 SUPER CAMPER

All-new eight-foot pickups with a full 140-inch wheelbase—the longest ever offered in a Ford pickup. The result is good weight distribution for this pickup's 8350- to 10,000-lb. GVW and better handling with big slide-in campers up to 12 ft. long. And this Super Camper Special attains its maximum 10,000-lb. GVW with single rear tires—big "Super Singles" (12.00 x 16.5 tires). Ford's new bodyside spare tire mount tucks your optional spare within the right side of the pickup box wall. A big 360 CID V-8, SelectShift Cruise-O-Matic, and all the other features shown in the Camper Special package below are standard.

F-250/F-350 CAMPER SPECIALS

The F-250 Camper Special with 133-in. wheelbase provides a maximum GVW of 8100 lb., and is designed to carry 11-ft. campers. Ford F-350 Camper Specials are available with 137-in. wheelbase for up to 12-ft. chassis-mounted campers. 161-in. wheelbase F-350 with dual rear wheels has a GVW rating up to 10,000 lb. for chassis-mounted, cab-over camper bodies up to 14-ft. long.

Camper Special package includes: 55-amp. alternator, 70 amp-hr battery, oil pressure gauge, ammeter, bright 6" x 10" Western long arm mirrors, front and rear stabilizer bars, heavy-duty transmission oil cooler (with Cruise-O-Matic), extra cooling package, camper wiring harness and dual electric horns. Camper options include: 460 CID V-8, frame-anchored camper tie-down system and dual batteries.

F-100 RANGER XLT

The glamour leader of the F-100 line! Outside and inside there's luxury that's highlighted by bright exterior trim treatment and interior comfort, convenience and appearance items.

The Ranger XLT offers color-keyed quilted cloth with vinyl trim seat upholstery, color-keyed pleated vinyl upper door panels with woodtone accented moldings and map pocket lower panels, color-keyed wall-to-wall nylon carpeting, carpeted behind-seat storage area, and a host of other luxury features.

CLUB WAGON Designed to bring your entire group together in spacious comfort. These versatile vehicles can easily seat as many as 12 adults. Or, with seating for five, Club Wagons have enough room left over for twice the gear that conventional wagons carry.

Two wheelbases are available, 105½-in. for 5- and 8-passenger seating and 123½-in. for 5, 8 and 12 passengers. Ford's famous Twin-I-Beam independent front suspension smooths the ride, and wide-track design provides exceptional highway stability, even in gusty winds.

Center-Guide sliding side door opens and closes easily with one-hand operation. Door shuts solid and tight. Conventional hinged doors are available. As is a wide array of options from air conditioning to SelectShift Cruise-O-Matic transmission.



Chateau Club Wagon

ECONOLINE CAMPER SPECIAL

A sturdy foundation with most of the important chassis components for today's camper service built right in (shown below with typical 19-ft. cab over chassis-mounted camper).

Standard features include: 302 CID V-8 engine, SelectShift Cruise-O-Matic, power steering, power brakes, 23-gal. fuel tank, 70 amp-hr battery, heavy-duty shock absorbers, and other items that contribute to solid ride and performance.

Truck body installation and modifications are the responsibility of the body manufacturer. Owners should assure themselves of the load and handling capabilities of their vehicle when selecting a camper or contemplating custom add-ons and modifications.



Econoline Camper Special with typical cab-over chassis-mounted camper



Ford Fun Fleet with fun and comfort in the out-of-doors from Pinto to Thunderbird



F-350 Ranger XLT Super Camper Special

F-250 Ranger Camper Special

F-100 Ranger XLT with optional deluxe box cover



Ford Ranchero



Ford Bronco with Ranger option

RANCHERO

The beauty of the 1973 Ranchero is just that—its beauty. The beauty of a car with the utility of a pickup with a 6½-ft. cargo body plus styling, ride and handling. There's interior luxury you'll find hard to believe in a pickup. Pick from three models—basic Ranchero 500, Ranchero GT and Ranchero Squire.

Options that make it even more like a sports or luxury car. Things like SelectAire Conditioner, Flight Bench Seat (Ranchero 500 and Squire), SelectShift Cruise-O-Matic, Mag-style wheels, dual racing-type mirrors, and more. Class II and III Towing Packages are also available to let you go trailering with class.

BRONCO

Combines off-road agility with new power and dress-up options. Available this year with the proven 302 CID V-8 optional engine is SelectShift Cruise-O-Matic transmission and power steering.

The **Sport Bronco** optional package can be dressed up with the new **Ranger Package** which includes color-keyed full carpeting (including tailgate and wheelhousings), and interior trim accents plus exterior extras like hood and lower bodyside tape stripes, swing-away spare tire carrier with tire cover, and others.

Bronco is an adventuresome four-wheeler that can get up, over, around or through all kinds of obstacles. Yet it has a comfortable ride with sporty front bucket seats and car-like appointments.

TRAILER TOWING PACKAGES

Ford and Torino wagons offer special trailer towing packages that pull your travel trailer, camping rig, boat or utility trailer with ease and safety.

For big Ford wagons and sedan models you can select Class I, II or III Trailer Towing Packages. These are designed to handle from up to 2000-lb. to 6000-lb. gross trailer weight. Each has its own specially designed items. A complete listing is on page 9 of this catalog.

For Torino there's a Class II or III package available to handle from up to 3500-lb. to 6000-lb. gross trailer weight.

A Class I Towing Package is also available for Pinto 2-Door and Runabout models.

For Thunderbird, there's a heavy-duty towing package.

If you wish more information on the Ford Recreation Fleet see your Ford Dealer for the 1973 Ford Recreation Vehicles catalog.

FORD CARES ABOUT YOUR SAFETY

Ford Motor Company Lifeguard Design Safety Features. Ford has been a pioneer on safety design in the automotive industry. Our Safety Research Center has developed stronger, safer, more dependable automotive products for you.

You'll find this reflected in each new 1973 Ford model which includes these FORD MOTOR COMPANY LIFEGUARD DESIGN SAFETY FEATURES, standard: Improved front and rear bumpers • Improved impact-absorbing laminated safety glass windshield • Dual hydraulic brake system with warning light • Glare-reduced instrument panel padding, windshield wiper arms, steering wheel hub, rearview mirror/mirror mounting and windshield pillars • Energy-absorbing steering column and steering wheel • Energy-absorbing armrests and safety-designed door handles • Front and rear lap belts with mini buckles for all seating positions and retractors for front and rear outboard occupants • Shoulder belts for front outboard occupants • Positive reminder warning light and buzzer for front outboard seat belts • Turn indicators with lane-changing signal feature • Inside yield-away rearview mirror • Energy-absorbing instrument panel with padding for center and outboard passengers • Padded sun visors • Locking steering column with warning buzzer • Two-speed windshield wipers • Windshield washers • Double-yoke safety door latches and safety hinges • Steel guard rails in side doors • Hazard warning flasher • Backup lights • Side marker lights • Energy-absorbing front seat back tops with padding • Self-locking front

seat back on two-door vehicles • Safety designed coat hooks • Safety-designed radio control knobs and push buttons (on all cars equipped with radios) • Outside rearview mirror, driver's side • Safety rim wheels and load-rated tires • Corrosion-resistant brake lines • Uniform transmission shift quadrant (on cars equipped with automatic transmissions) • Parking lamps coupled with headlamps • Non-reversing odometer • Safety design front end structure • Head restraints or high back seats for front outboard occupants • Safety glove-box latch (on all cars equipped with glove boxes).

Built-in safety is something you have going for you in every Ford, Torino and Pinto wagon. Take full advantage of this protection as you drive. Obey all traffic laws, think ahead and always buckle up for safety.

Economy of Operation: All 1973 Ford, Torino and Pinto wagons call for 36,000 miles, or 3 years (whichever comes first), between major chassis lubrications, 4,000 miles, or 4 months, between oil changes. Oil filter change initially at 4,000 miles, or 4 months, and at 8000-mile or 8-month intervals thereafter. Other economy features include: self-adjusting brakes, 2-year engine coolant-antifreeze, long-life Motorcraft Sta-Ful battery, corrosion-resistant aluminized muffler, zinc-coated underbody parts, use of regular gas*, and more.

NOTES:

Color Codes. For your convenience, each illustration is color coded (example: Color 4B). Your Ford Dealer will be pleased to show you a color chip and actual swatches of vinyl roof and interior trim materials.

*All 1973 engines are designed to operate on regular gas with octane rating of at least 91 (Research Method) when the engine is adjusted to factory-recommended specifications.

Replacement Parts. Your new 1973 Ford, Torino and Pinto wagon comes with factory-engineered Motorcraft battery, oil filter, shock absorbers; Autolite Powertip Spark Plugs and other Ford-approved precision parts. For continued top performance, be sure to specify Motorcraft Parts and Autolite Powertip Spark Plugs whenever replacement is necessary.

Illustrations and information presented were correct when approved for printing. Ford Division reserves the right to discontinue or change at any time, specifications or design without incurring obligations.

Some features shown or described are optional at extra cost. Most options are offered on all models. Some options are required in combination with other options. Availability of some models or some features described may be subject to a slight delay.

Always consult your Ford Dealer for the latest, most complete information on models, features, prices and availability.

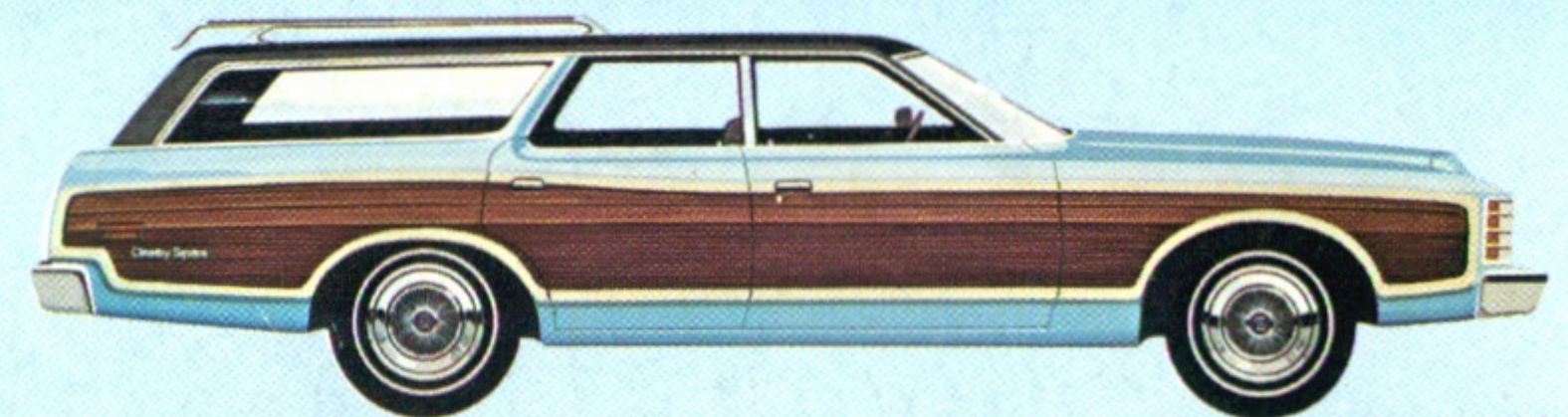

Ford LTD Country Squire (Color: 3B)
(6-passenger and Dual Facing
Rear Seat models)



Ford Galaxie 500 Country Sedan (Color: 2L)
(6-passenger and Dual Facing
Rear Seat models)



Ford Custom 500 Ranch Wagon (Color: 4Q)
(6-passenger and Dual Facing
Rear Seat models)



Ford Gran Torino Squire (Color: 4S)

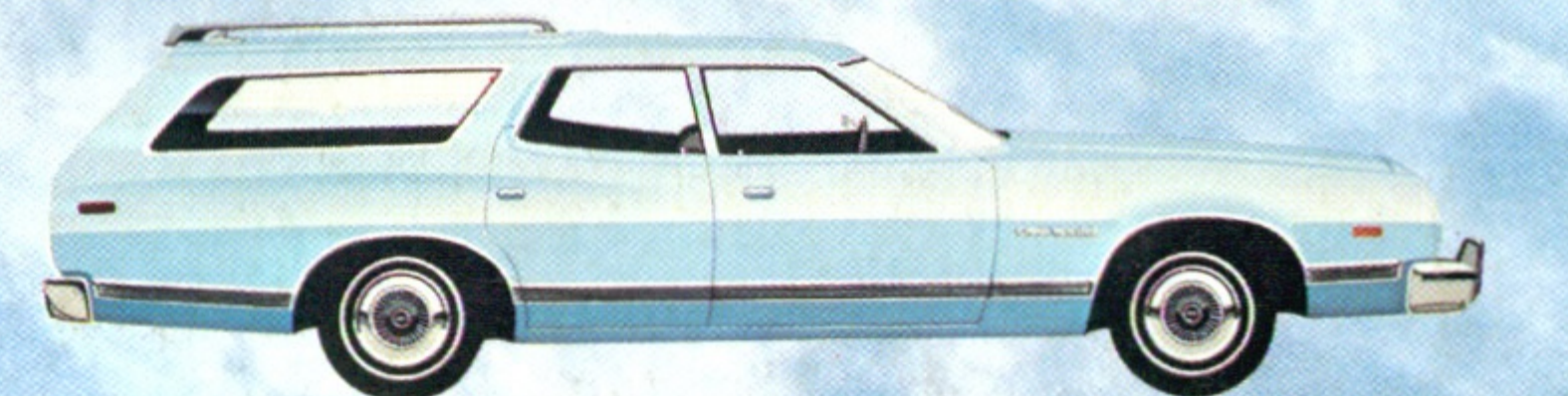

Ford Gran Torino Wagon (Color: 3B)



Ford Torino Wagon (Color: 3D)



Ford Pinto Wagon (Color: 5L)
(Squire Option)



Ford Pinto Wagon (Color: 4P)



Listening better. Building better. That's Ford.

FORD DIVISION

