

GMC S-15 PICKUPS



1985

TRUCKS ARE WHAT WE'RE ALL ABOUT



GMC S-15 TRUCKS



2-WD S-15 Sierra Classic Pickup*

4-WD S-15 Sierra Pickup

4-WD S-15 Sierra Classic Club Coupe Pickup

2-WD S-15 Sierra Classic pickup

THEY'RE BIG WHEELS ON THE COMPACT TRUCK SCENE
We predicted we had a winner when the GMC S-15 Pickup was introduced to the public in 1982 — and three years later, thousands of enthusiastic owners prove that we were right! We're proud of S-15's success, and we're constantly striving to make these great trucks even better. Here are some innovations for 1985:

NEW TWO-TONE PAINT AND TRIM FOR '85!

New Custom Two-Tone paint, which includes new body striping, is available for all Pickup and Club Coupe models (see details on back cover). Other new trim includes restyled fender nameplates and a new paint scheme for available styled wheels.

BLACK IS "IN" FOR '85!

... and S-15 has it — with new black chrome finish for the Gypsy grille, headlamp/side marker lamp bezels, door handles, key cylinder covers, and taillamp bezels. Antennas included with available radios also have the new black chrome finish.

NEW-LOOK INTERIORS

You may choose one of four colours for the new available custom vinyl and custom cloth seat trims, depending upon model; the new custom cloth fabric also is used for Sierra Classic door trim panel inserts.

NEW 2.5 LITRE GASOLINE ENGINE

More power to 4-cylinder engine equipped '85 S-15s — with a new 2.5 Litre (151 CID) electronically fuel-injected in-line gasoline engine that's available on most gasoline-engine models! It's combined with a standard 4-speed manual transmission. (See page 11 and back cover for details about available drive-trains.)

NEW BUILT-IN IMPROVED QUALITY FOR '85!

Some improvements aren't visible, but they help add to your S-15's toughness, serviceability, driveability, and longevity. Such as: new partitioned fuse panel; 2-side-galvanized steel used for hood inner panel and fender skirts; welded-on bumper brackets and larger front bumper mounting bolts; new adjust-on-release rear brake adjusters; new valving for shock absorbers; new controls for available intermittent wipers; new variable-ratio manual steering gear. And there's more ... read about '85 GMC S-15 Pickups in this brochure, then ask your GMC Dealer about a demonstration drive.

HIGH TECHNOLOGY AND VALUE

GMC S-15 high-technology trucks are produced by the combined efforts of skilled GM personnel dedicated to the goal of building trucks that set new standards for quality build, comfort, convenience, aerodynamic efficiency, corrosion protection, paint

quality, and high mileage.

The final result of research, planning, designing, and testing is the manufacture of a quality vehicle worthy of the GM name. The S-15 compares favorably with any import. See it today at your GMC dealership and make your own evaluation.

GMC S-15 MODEL AVAILABILITY

	Body Type	Engine Type	Rated Payload, Kg (Lb)	Box Length, Mm (In)	Wheelbase, Mm (In)
TWO WHEEL DRIVE	2-Door Conventional Cab Pickup	Gasoline	454 (1000) 680 (1500) 737 (1625)	1857 (73) 2261 (89)	2750 (108.3) 2995 (117.9)
		Diesel	454 (1000) 567 (1250)	1857 (73) 2261 (89)	2750 (108.3) 2995 (117.9)
	2-Door Club Coupe Pickup	Gasoline	454 (1000) 680 (1500)	1857 (73) 2261 (89)	3122 (122.9)
		Diesel	454 (1000) 567 (1250)	1857 (73)	3122 (122.9)
FOUR WHEEL DRIVE	2-Door Cab & Chassis	Gasoline	1860 (4100) & 2087 (4600) GVWR	—	2995 (117.9)
		Gasoline	454 (1000) 680 (1500)	1857 (73) 2261 (89)	2750 (108.3) 2995 (117.9)
	2-Door Club Coupe Pickup	Gasoline	454 (1000) 680 (1500)	1857 (73)	3122 (122.9)
		Gasoline	454 (1000) 680 (1500)	1857 (73)	3122 (122.9)

*Tires are supplied by various manufacturers

GMC GYPSY



2-WD Gypsy Pickup. Tires are supplied by various manufacturers.

AERODYNAMIC GYPSY

Let your eye follow Gypsy's aerodynamic lines from drag-filing front air dam to black tailgate applique. Take note of the special exterior styling details: Sport two-tone paint scheme; new paint treatment for 2-WD model styled wheels; new black chrome finish for grille, headlamp/side marker lamp bezels, taillamp bezels, door handles, and key cylinder covers. Distinctive black colour also is used for the flared wheel-lip mouldings, body-side mouldings, standard or available dual mirrors, and windshield and rear window mouldings.

Step inside and experience total luxury. Sink into foam-padded high-back bucket seats, stretch your legs ... there's plenty of room. Seats are upholstered in special sport cloth; or, for ultimate posh, order available sheepskin seat trim. Place your personal items in the large lockable console between the seats. Dual sliding sunshades foil the sun's glare. Deluxe heater/ventilation system has side defoggers to keep door glass mist- and fog-free. Gypsy's electrical features include door-operated courtesy and dome lights; cigarette lighter with lighted ashtray; lighted lockable glove box; and headlamp warning buzzer.

Gypsy Features More Good Things. The Gypsy package has more good things, like colour-keyed cut-pile carpeting on floor, cab back panel, and lower doors. There's a coin holder in the left door; and both doors have a map pocket in the lower carpet panel. Extra insulation helps create a quiet ride. See page 10 for other standard and available equipment.

Looks are important and so are comfort and convenience, but the real test of a truck is performance. So, grasp the sport steering wheel, set the trip odometer, start the engine, and prepare for real driving pleasure.



Gypsy interior includes lockable console for storing personal items



4-WD Gypsy Pickup takes the high country in high style



Gypsy trim includes a sport steering wheel and gauge package with trip odometer

GMC CLUB COUPE



2-WD Sierra Classic Club Coupe*



Sierra Classic Club Coupe interior



Sierra Classic instrument panel



Right front bucket seat slides forward for access to rear compartment

A Rugged S-15 Pickup with something extra — 370.8 mm (14.6") added cab length on a 3122 mm (122.9") long wheelbase — that provides room for up to four persons, or 0.5 cu m (18.4 cu ft) of protected in-cab cargo space behind front seats to tuck away your gear.

Four persons can be accommodated — two in available high-back front bucket seats and two in available centre-facing rear jump seats (seats included with Sierra Classic and Gypsy trim). A reclining feature is available for front bucket seats. Rear quarter windows are standard, and windshield and all windows have standard glare-softening tinted glass. Door-operated courtesy and dome lights are standard

conveniences. Full floor insulation and full insulated headliner help keep in-cab noise under control.

Club Coupe comes in 2-wheel or 4-wheel drive, with rated payloads of 454 or 680 kg (1000/1500 lb) with gasoline engines, and diesel models with payloads of 454 or 567 kg (1000/1250 lb).

*Tires are supplied by various manufacturers

GMC SIERRA CLASSIC



2-WD Sierra Classic conventional-cab Pickup*



Sierra Classic conventional-cab Pickup full-foam bench seat with new custom cloth trim



Sierra Classic deluxe colour-keyed steering wheel and instrument panel

Top Appearance And Value. Sierra Classic adds extra touches of bright exterior trim: chromed front bumper with bright-trimmed, full-width rub strip; black grille with chrome trim; and chromed taillamp trim. Wheel openings are outlined with bright mouldings, and black body-side mouldings with bright trim are another dressy addition.

It's hard to remember you're in a tough, hardworking truck when you settle down in a Sierra Classic interior. Your surroundings are fully trimmed and colour-coordinated. Included are such extras as: side window defoggers; cigarette lighter with lighted ashtray; lighted glove box; door-operated dome light; gauge package with trip

odometer; carpet on floor and lower doors; dual sunshades that slide to put the shade where you need it.

To learn about Sierra Classic basics, technical features, and additional customizing options, please check pages 6 through back cover of this catalogue. Ask your GMC Dealer about a demonstration drive of a Sierra Classic Pickup.

*Tires are supplied by various manufacturers

GMC HIGH SIERRA



4-WD High Sierra conventional-cab Pickup. Special paint is dealer-installed.*

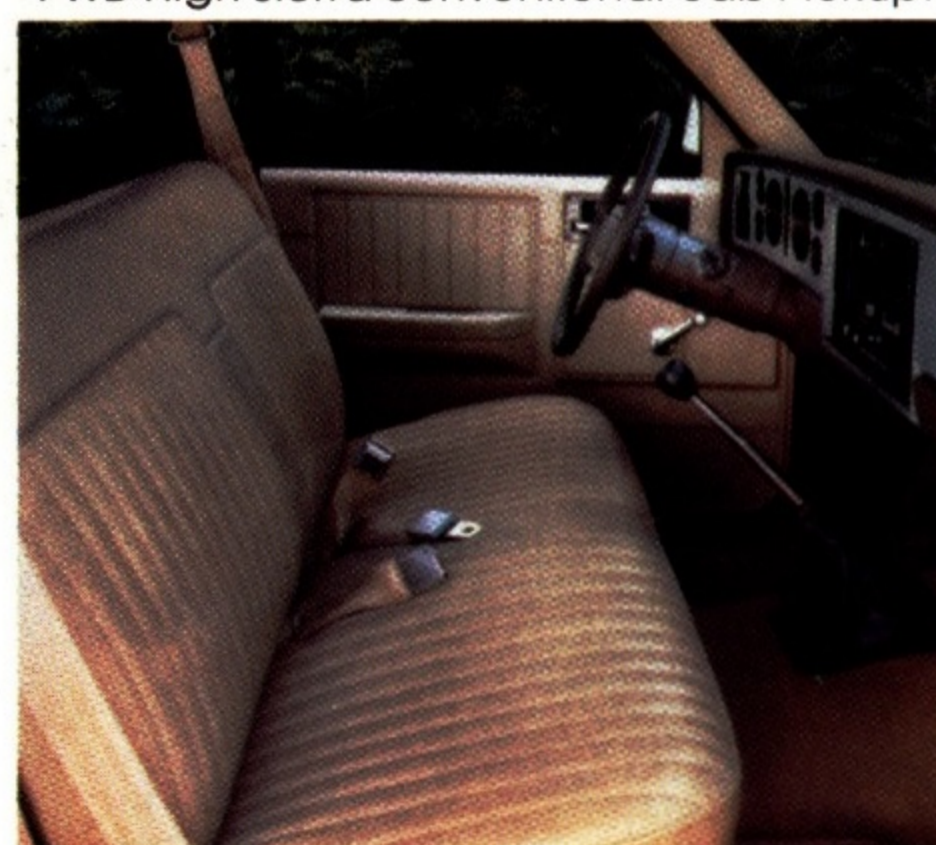

High Sierra interior with custom vinyl full-width bench seat



High Sierra instrument panel and deluxe colour-keyed steering wheel

Midrange Luxury Trim. High Sierra is a midrange trim which adds more sparkle outside and more convenience inside than the standard trim.

The chromed front bumper has a black full-width protective rub strip that's bright-trimmed. Chrome highlights the black grille. Bright wheel trim rings and bright taillamp trim add to the exterior sparkle.

Inside, experience the comfort and convenience of such features as deluxe heating system with side window defoggers — and extra lighting with door-operated courtesy and dome lamps, lighted glove box and ashtray, and a headlight warning buzzer. You may select new custom vinyl or new custom cloth trim for the

standard bench seat. Custom vinyl high-back bucket seats and locking console are available. This interior, fully colour-keyed, also includes: deluxe steering wheel and column, rubber floor mats over full-floor insulation, cloth-covered foam full headliner, and dual cloth-covered sunshades with a sliding feature to give you large sun-blocking coverage.

Read pages 6 through back cover for more facts. See why High Sierra is the high-quality, high-value S-15 Pickup.

*Tires are supplied by various manufacturers

GMC SIERRA



2-WD standard Sierra S-15 Pickup



Sierra cab interior with standard vinyl full-width bench seat



Standard black steering wheel and easy-to-read instrument cluster

Quality And Value. Our standard 1985 S-15 Pickups offer deep-down quality, aerodynamic styling, outstanding appearance, and interior comfort and convenience that is apparent in every carefully engineered detail.

Your choice of ten solid-paint colours is accented by low-gloss black for the front bumper, windshield and rear window mouldings, and dual mirrors. Dressy new Custom Two-Tone paint schemes, body side mouldings, chrome front and rear bumpers, and other customizing trim are available. Dark argent grille and chromed headlamp/side marker lamp bezels are standard.

The three-passenger full-width, full-foam bench seat is vinyl-covered in

your choice of four colours (Blue, Carmine, Charcoal, Saddle Tan) to match instrument panel, full door trim, partial cloth-covered headliner, windshield pillar mouldings, and lap/shoulder belts. Dual sunshades are colour-keyed and the left-hand visor has a sliding feature for increased coverage. Courtesy light and glove box with locking door are included. Insulated rubber floor mat, steering wheel, and steering column are black.

See pages 6 through back cover for all the reasons why '85 S-15 is a great compact pickup value!

GMC S-15 TRUCKS WITH INSTA-TRAC 4-WD



Insta-Trac permits shifting from 2-WD into 4-WD High at any speed, without stopping. A lighted display tells you what mode you're in.

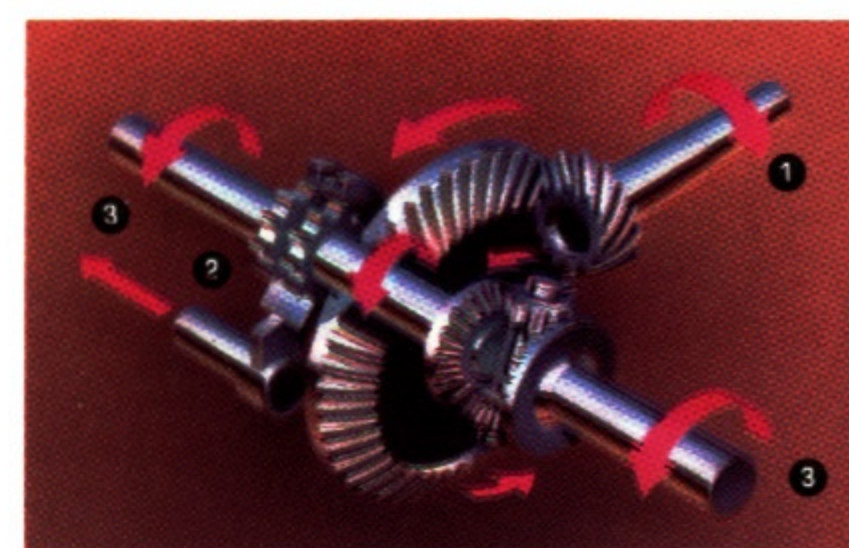

4-WD FRONT-AXLE DIFFERENTIAL

- 1 Power comes from transfer case
- 2 A locking sleeve engages right side of axle to transmit power to both front wheels
- 3 In 4-WD, both front wheels turn under power. Shifting from 4 HIGH to 2 WHEEL disengages the locking sleeve, permitting front free-wheeling efficiency.



Lightweight cast aluminum wheels are available for 4-WD S-15 Pickups



4-WD Sierra Classic Pickup

NON-STOP 4-WD TRACTION AT ANY SPEED

GMC's Insta-Trac system responds instantly to your hand on the transfer case shift lever to change your driving mode from 2 WHEEL to 4 HIGH. No stopping to get out and lock the hubs, no second lever to set. You won't have to slow down unless the terrain calls for 4 LOW — then just stop, shift to 4 LOW and resume driving — stop again to shift out of 4 LOW; it's that simple! Insta-Trac is a GM exclusive.

4-WD UNDERCARRIAGE PROTECTION

The front and rear differentials, transfer case, and transmission are sealed against mud and water intrusion. Shields for fuel tank, front differential, and transfer case are available.

S-15 4-WD RUGGED CHASSIS

S-15 4-WD Pickups offer impressive advantages such as a torsion bar front suspension that lets each wheel take its bumps independently. Front and rear suspensions are mounted to a tough, reinforced frame. High axle ground clearance and good ride stability are additional features. Rubber mountings cushion the bounce to provide a good off-road ride and smooth highway performance. Standard and available 15" highway tires have the new All Seasons tread for improved traction in mud and snow. Standard front stabilizer bar, power steering, and power brakes contribute to good handling characteristics. An available off-road handling package includes new Delco/Bilstein gas-pressure shock absorbers for

impressive suspension action both on and off the highway.

2.8 LITRE V6 ENGINE STANDARD

A powerful 2.8 Litre V6 gasoline engine is standard. And, for '85 there's a new available 2.5 Litre electronically fuel-injected in-line 4 gasoline engine. When equipped with the available Trailering Special package, standard V6 engine, and other required equipment, a 4-WD S-15 can tow a trailer weighing up to 1814.4 kg (4000 lb) — that includes trailer, equipment and cargo. See adjacent chart.

Check pages 8 through back cover for more facts about GMC S-15 4-wheel-drive Pickups.

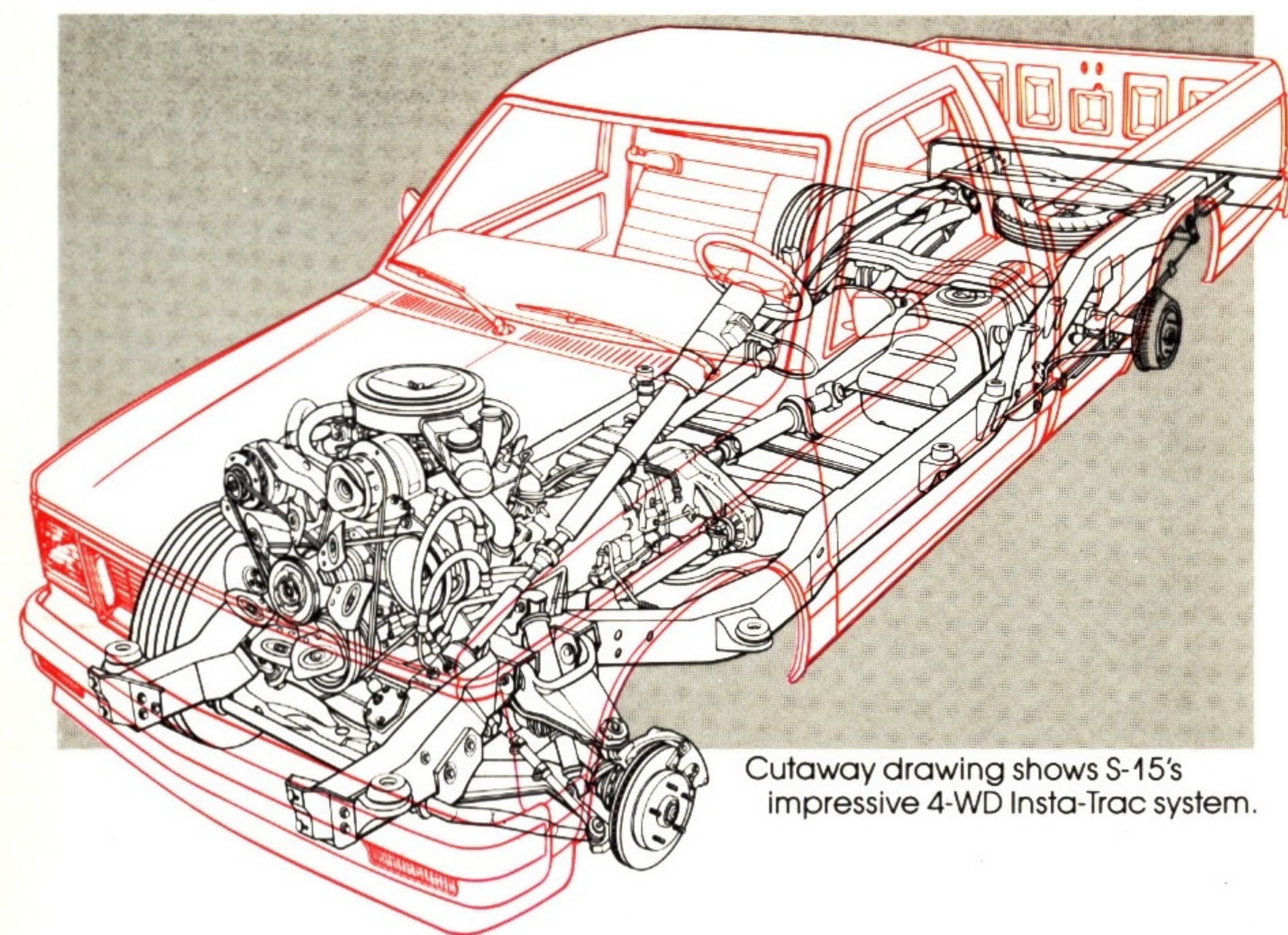

Cutaway drawing shows S-15's impressive 4-WD Insta-Trac system.



TRAILERING WITH S-15 PICKUPS

Move up to 2268 kg (5000 lb) with available Trailering Special package and other required equipment (see chart below). Consult your GMC Dealer for complete details.

Series	S-15 2-WD				S-15 4-WD
	Pickup		Club Coupe		Pickup, Club Coupe
Model					
Payload Rating, kg (lb)	680/737 (1500/1625)		680 (1500)		680 (1500)
Trailer Weight, kg (lb)	1814.4 (4000)	2268 (5000)	1814.4 (4000)	2268 (5000)	1814.4 (4000)
Axle Ratio	3.73:1		3.73:1		3.73:1*
Engine	2.8 Litre V6 Gasoline				
Transmission	4-Speed Automatic Overdrive				
Engine Oil Cooler	—	KC4	—	KC4	—
Hitch	Weight-distributing Platform Type				

*When P235 tires are ordered, 4.11 axle ratio is required

GMC S-15 CAB & CHASSIS



Sierra S-15 Cab & Chassis with available aftermarket utility body



Utility body with ladder rack

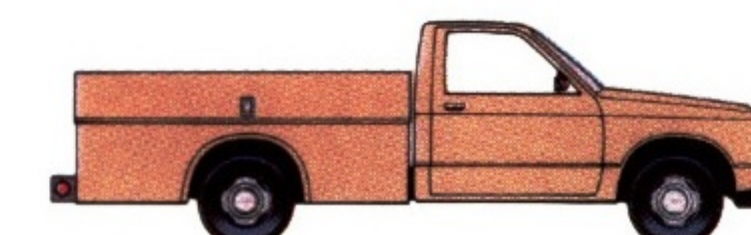

Special contractor body

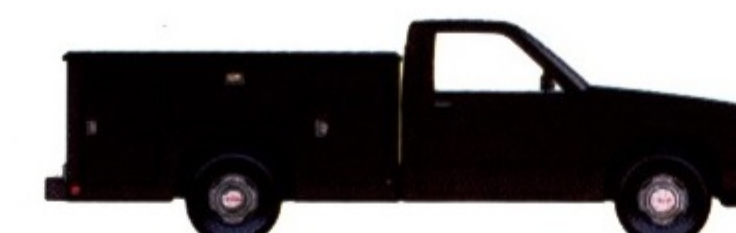

Utility body with side doors



Van body without refrigeration

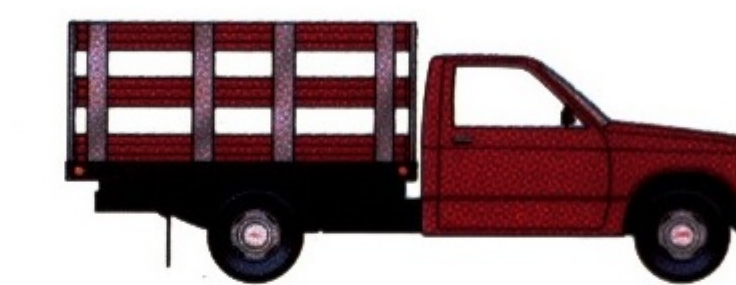

Stake rack body



Large-capacity utility body

Bodies shown represent some of the types available from various aftermarket manufacturers

Many operators looking for economical, maneuverable transportation for equipment, tools, or goods are turning to the midsize S-15 Cab & Chassis. Specialized aftermarket commercial bodies up to 2.29 metres (7-1/2') long can be mounted on the 2995 mm (117.9") wheelbase.

Standard drivetrain is the 2.8 Litre V6 gasoline engine with a 4-speed manual fully-synchronized transmission. A

new electronically fuel-injected 2.5 Litre I4 gasoline engine is available. The standard GVWR is 1860 kg (4100 lb). To obtain the maximum 2087-kg (4600-lb) GVWR requires standard 2.8 Litre V6 engine plus available power brakes, front stabilizer bar, and heavy-duty rear springs.

See your GMC Dealer for further details about these versatile models.

GMC QUALITY BENEFITS

DOUBLE-WALL CONSTRUCTION

Double walls of steel are used in the hood, front fenders, side doors, and portions of the cab back panel and Club Coupe rear quarter panels. They're also used in the pickup box sidewalls and tailgate.

ONE-PIECE BODY PANELS

Single stampings for major body panels not only help contribute to overall body structural rigidity, but also dimensional stability for good fit of installed parts. For example, one-piece-design door-opening frames help provide good fit, alignment, and sealing of doors, as do hinges welded to the door frames.

CARBON STEEL FULL FRAME

All GMC S-15s have a full frame of carbon steel with a welded front box section and open channel rear section. New welded on front bumper brackets and new larger bolts improve bumper-to-frame attachment for '85.

DELCO TRON GENERATOR

A high-capacity, 56-amp Delcotron generator is standard on gasoline engine models; diesel engine models have a 66-amp unit as standard equipment. The 66-amp Delcotron generator is available for gasoline engine models, and is included with available air conditioning and the Cold Climate package.

DELCO FREEDOM II BATTERY

Never requires the addition of water. Features lead-calcium grids to help eliminate overcharge and self-discharge, built-in hydrometer, and corrosion-resistant terminals. Heavy-duty battery is available for gasoline engine models, and is included with available Cold Climate package. Diesel engine models have an extra-heavy-duty battery as standard equipment.

SALISBURY-TYPE REAR AXLE

The standard semifloating rear axle has a 190.5 mm (7-1/2") ring gear designed for the S-15. Capacity is 1179 kg (2600 lb) for 2-WD; 4-WD models have a 1224-kg (2700-lb) axle. Locking differential is available with certain axle ratios.

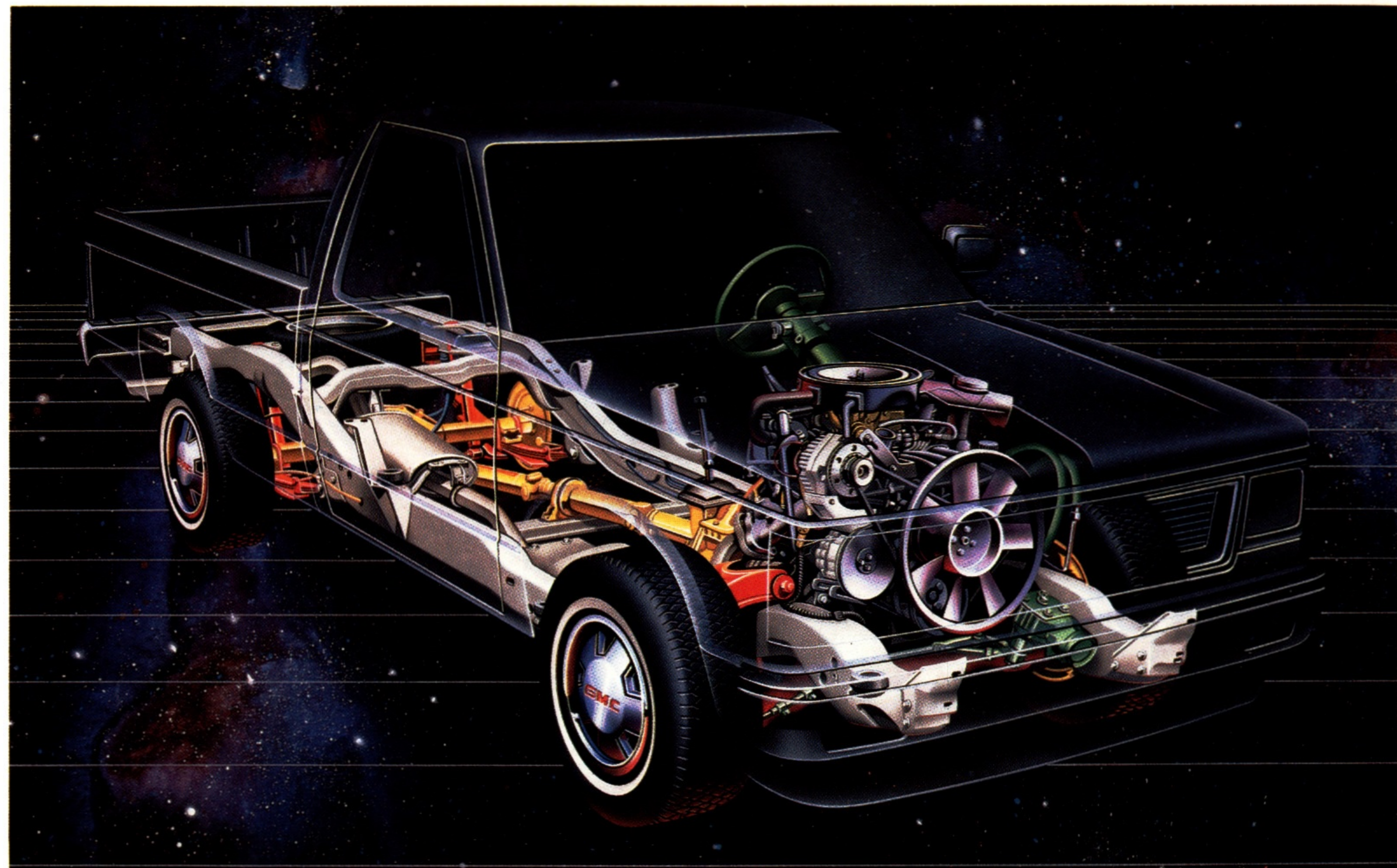

2-WD Sierra Classic S-15 Pickup shown with available equipment

WINCH-TYPE SPARE TIRE CARRIER

Changing a flat is never fun but the S-15 Pickup standard carrier with winch cable to lower or raise the stored spare makes the job a lot easier. Cab & Chassis models are delivered with the spare attached to the top of the frame.

4-WD OFF-ROAD CHASSIS PACKAGE WITH GAS-PRESSURE SHOCKS

Available for 4-WD Pickups and Club Coupes with the 680-kg (1500-lb) payload option. Included new Delco/Bilstein gas-pressure shocks give impressive control of suspension movement and help traction on and off the highway. Option also includes: shields

for fuel tank, transfer case, front differential carrier; front tow hooks; P235 on/off-road tires; special torsion bars, jounce bumpers, and front stabilizer bar; and wheel trim rings.

2-WD SPORT SUSPENSION PACKAGE

Available for gasoline engine conventional cab Pickups. Includes: power steering; P215/65R-15 steel-belted radial ply white lettered tires; styled wheels; special front stabilizer bar; heavy duty front and rear shock absorbers. Requires available 680- or 737-kg (1500- or 1625-lb) payload rating.

ANTI-CORROSION MEASURES

- Coated steels used for many parts, including 2-side-galvanized steel for front fender skirts and hood inner panel in '85
- Eight-stage zinc phosphate and wash system
- Cathodic Elpo dip primed during assembly
- Anti-chip coating applied to rocker panel from back of front wheel to rear of truck
- Primer surfacer on all exterior surfaces
- Acrylic enamel top coat on all interior and exterior surfaces

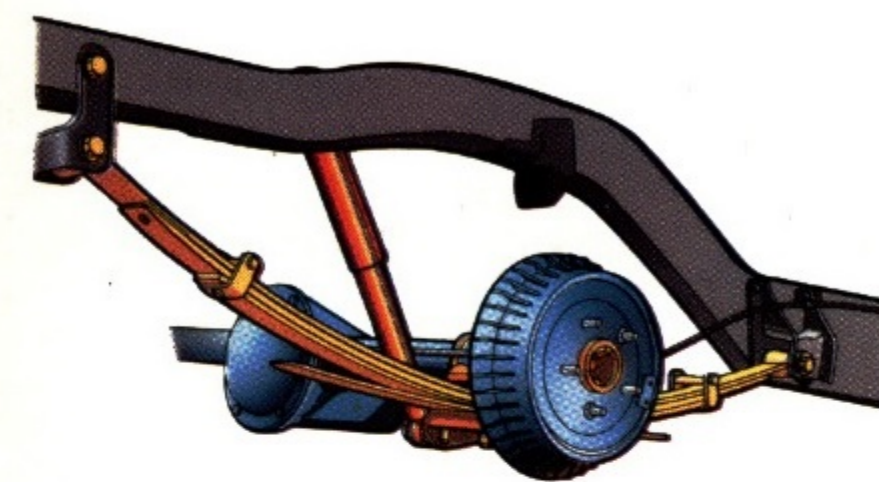

Two-stage multileaf rear springs provide a soft ride with a light load and firmer support as the load increases.

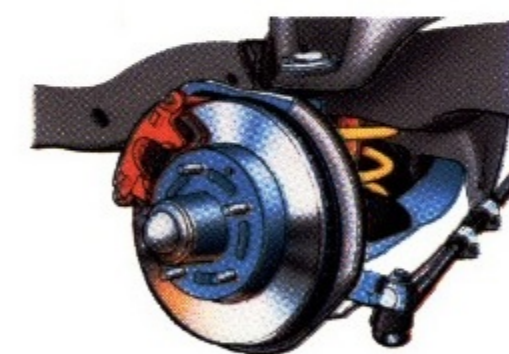

Front disc brakes are standard. Power brakes are standard on all models except gas engine 2-WD conventional cab models.



Front independent suspension steps smoothly over bumps and ruts. 2-WD suspension shown.



Side-window defoggers are a part of the standard deluxe heater system for all models except Sierra.



All front seat backs tilt forward for access to storage space or Club Coupe rear compartment. Conventional cab bench seat shown.

- Protective primers and finish enamel film build of 3.1 mils
- Supplemental wax coatings in door cavities
- Small parts individually processed for added protection
- Frames dipped in hot melt wax at manufacturing plant

As Part of the GMC Truck New Vehicle Limited Warranty, Perforation from Corrosion is Covered for Three Years. Exhaust components not included. See your GMC Dealer for details about other limitations.

GM PROTECTION PLAN

An option that offers service protection beyond that provided by GM's new vehicle limited warranty; includes rental, towing provisions. Available only in Canada and the U.S.A. during the 1985 model year. See your dealer for details.



At General Motors, a lot of new thinking has gone into our products. New thinking aimed at completely satisfying you, the customer. Our designers and engineers are making history in aerodynamic design, computer aided technology, fuel efficiency and safety.

As further proof of our goal of totally satisfying you, at GM dealerships we are implementing a "Commitment to Excellence" Delivery Procedure.

The program includes: a thorough new-vehicle inspection by both the service technician and the salesperson; a full tank of fuel; plus a follow-up survey based on your impression of the delivery process.

With a commitment like that, you've got a lot of excellent reasons to "Look at GM Today". See your dealer for complete details.

Available Equipment



Selected GM-Delco radios

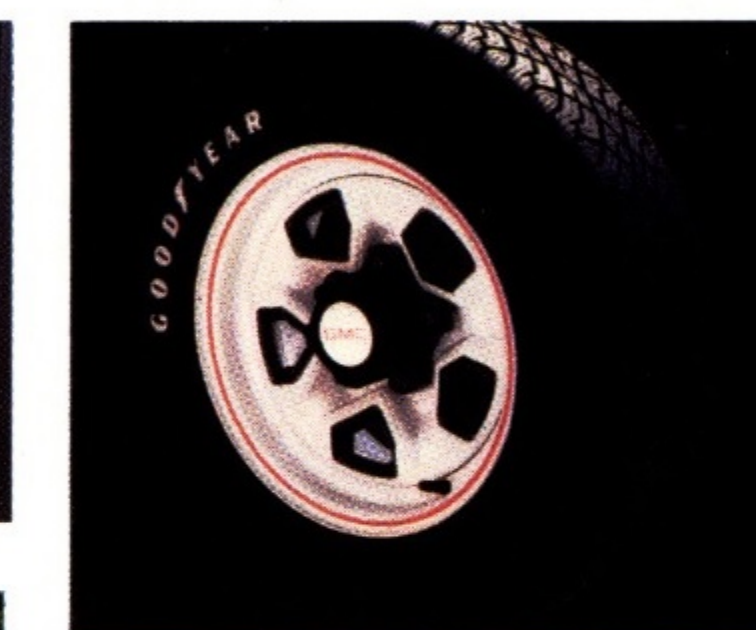

Styled wheels for 2-WD models



Bucket seats

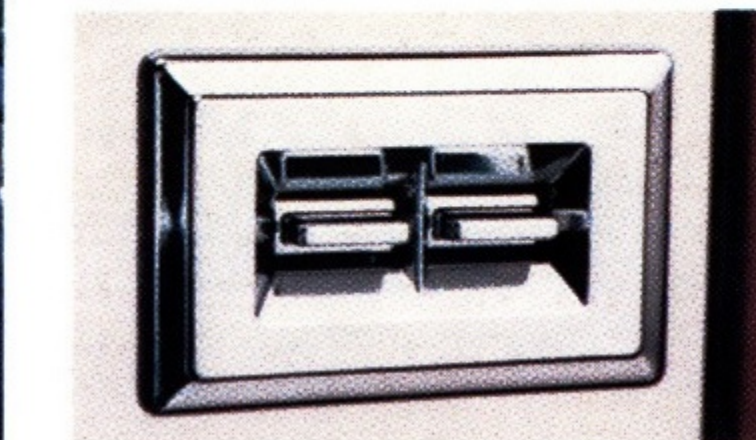

Power windows

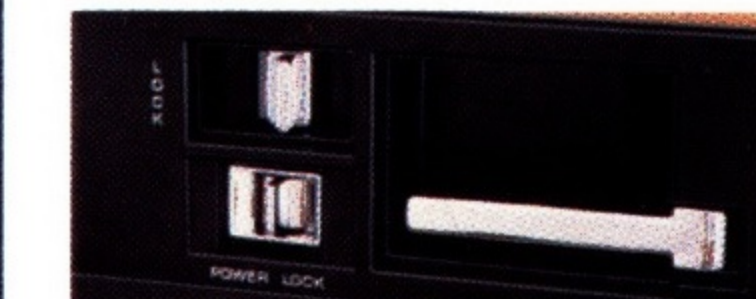

Power door locks



All-weather air conditioning



Rear step bumper

GMC S-15 Pickups offer a large selection of the most wanted optional equipment — more than many import pickups. Choose from a vast array of interior appearance and convenience equipment, power and operating equipment, sound equipment, lighting equipment, exterior appearance and convenience equipment, and heavy duty and chassis equipment. Some of these items are listed on page 10.

New for '85: An electronic-tuned AM/FM stereo radio with cassette tape player, seek/scan and graphic speaker equalizer features, digital clock, and premium rear speakers. Styled wheels, available for 2-WD models and standard with Gypsy trim, feature a new, sporty white/black/red paint treatment for 1985.

See your GMC Dealer for further details on how to equip your S-15 to suit your individual needs.

GMC Standard and Available Equipment

TRIM LEVEL		SIERRA (STD)	HIGH SIERRA (YC1)	SIERRA CLASSIC (YC2)	GYPSY (YC3)	
EXTERIOR APPEARANCE						
GRILLE/LAMP BEZELS	Dark Argent Grille; Chrome Lamp Bezels	S	—	—	—	
	Chrome and Black Grille; Chrome Lamp Bezels	A	S	S	—	
	Black Chrome Grille and Lamp Bezels	—	—	—	S	
IDENTIFICATION	Front	Integral GMC Letters on Grille	S	S	S	
		"2.2 DIESEL" Nameplate Under RH Headlamp on Diesel Models	S	S	S	
	Side	Specific Nameplate with Series Designation on Front Fenders	S	S	S	
		"4x4" Nameplate on Cab Upper Rear Quarter Areas on 4-WD Models	S	S	S	
	Rear	GMC Letters on Wheel Trim	S	S	S	
ORNAMENTATION	Front	Decal with GMC Letters on Tailgate (reflectorized on High Sierra)	S	S	—	
		Bright GMC Letters on Tailgate Applique	—	—	S	
	Side	Black Plastic Windshield Mouldings	S	S	S	
		Black Plastic Mouldings with Bright Trim	A(1)	A(1)	S	S
		Bright Wheel Opening Mouldings	A	A	S	
		Black Plastic Wheel Opening Mouldings	A	A	A	
		Body Striping (requires solid colour paint)	A	A	—	
		Door Handles	Bright	S	S	(2)
			Black	—	—	—
		Key Lock Cylinders	Bright	S	S	—
		Black	—	—	—	
Rear	Black Tailgate Applique with Bright GMC Letters and Trim	—	—	S	S	
	Tailamp Trim	Bright	—	S	—	
		Black	—	—	—	
WHEELS/WHEEL TRIM	2-WD	Argent Painted Conventional Wheels and Bright Hubcaps	S	S	—	
		Black Painted Conventional Wheels	—	—	S	
		White Painted Styled Wheels with Black and Red Trim and Black Hubs	A	A	A	S
		Bright Wheel Trim Rings	A	S	—	
		Bright Wheel Trim Covers	A	A	S	
		Cast Aluminum Wheels	—	—	—	
4-WD	Argent Painted Conventional Wheels and Bright Hubcaps	S	S	S	S	
	Bright Wheel Trim Rings	A	S	S	S	
INTERIOR APPEARANCE						
FLOOR COVERING	Embossed Black Rubber; Full-Length on Club Coupe	S	—	—	—	
	Colour-Keyed Rubber; Full-Length	—	S	—	—	
	Colour-Keyed Carpet; Full-Length (includes cab back panel)	—	—	S	S	
HEADLINER	Colour-Keyed Cloth Over Foam and Moulded Plastic	S(3)	S(3)	S	S	
INSTRUMENT PANEL TRIM	Textured Argent Finish for Main Components	S	S	—	—	
	Brushed Metal Finish for Main Components	—	—	S	S	
	Specific Nameplate on Stowage Box Door	S	S	S	S	
MOULDINGS/TRIM PANELS (all parts are colour-keyed)	Windshield Pillar Mouldings	S	S	S	S	
	Upper Door Mouldings (lock pillar side)	—	—	S	S	
	Lower Rear Window Moulding	—	—	S	S	
	Upper Rear Quarter Trim Panels	Conventional Cab	—	—	S	S
		Club Coupe	S	S	S	S
	Lower Rear Quarter Trim Panels	Conventional Cab	A(4)	A(4)	S	S
		Club Coupe	A(5)	A(5)	S	S
	Cowl Kick Trim Panels	A(6)	A(6)	S	S	
	Jack Cover	Conventional Cab	—	—	S	S
		Club Coupe (Black on Sierra models)	S	S	S	S
Door Trim Panels	Moulded Plastic with Integral Armrests	S	S	S	S	
	Black Housing in Door Latch Release Handle Area	S	S	S	S	
	Black Trim Plate Below Release Handle Area (7)	—	S	S	S	
	Brushed-Metal Finished Trim Plate in Window Control Area	—	—	S	S	
	Cloth Insert Above Armrest	—	—	S	S	
	Carpet Trim on Lower Area with Map Pocket	—	—	S	S	
COMFORT/CONVENIENCE/PROTECTION						
BUMPERS (rear bumpers must match front bumpers)	Front	Black Painted	S	—	—	
		Chromed with Bright-Trimmed Black Rub Strip	A	S	S	
		Colour-Keyed Painted with Bright-Trimmed Black Rub Strip	A(8)	A(8)	A(8)	S
	Rear Step-Type	Black Painted with Black Step Pads	A	—	—	—
		Chromed with Bright-Trimmed Black Rub Strips and Black Step Pads	A	A	A	—
	Colour-Keyed Painted with Bright-Trimmed Black Rub Strips and Black Step Pads	A(8)	A(8)	A(8)	A	
FLOOR MATS	Colour-Keyed Rubber; Front Only	—	—	A	A	
GLASS	Clear Glass All-Around (Conventional Cab only)	S	S	S	S	
	Tinted Glass All-Around (standard on Club Coupe)	A	A	A	A	

S- Standard
A- Available
1- Includes bright wheel opening mouldings.
2- Includes body colour inserts.
3- Partial coverage on Conventional Cab.
4- Part of optional stereo radio equipment.

TRIM LEVEL		SIERRA (STD)	HIGH SIERRA (YC1)	SIERRA CLASSIC (YC2)	GYPSY (YC3)	
COMFORT/CONVENIENCE/PROTECTION (cont'd)						
GLASS (cont'd)	Swing-Out Quarter Windows (Club Coupe)	With Tinted Glass	A	A	A	
		With Deep-Tinted Glass	A	A	A	
	Sliding Rear Window (not available with deep-tinted glass)	Conventional Cab: Fixed Rear Window (all other glass is tinted)	A	A	A	A
		Club Coupe: Fixed Rear Window and Swing-Out Quarter Windows	A	A	A	A
GRAB HANDLE	Over RH Door (4-WD models only)	S	S	S	S	
GUARDS	Bright Door Edge	A	A	A	A	
	Black Front Bumper (requires rub-strip-type bumper on Sierra models)	A	A	A	A	
HEATING/COOLING	Air Conditioning, Outside Air Type	A	A	A	A	
	Cold Climate Package (gasoline models only)	A	A	A	A	
	Flow-Through Power Ventilation	S	S	S	S	
	Heater/Defogger, Outside Air Type	S	—	—	—	
HORN	Heater/Defogger, Deluxe Outside Air Type with Side Window Defoggers	A(10)	S	S	S	
	Single Electric High-Note	S	S	S	S	
INSTRUMENT CLUSTER	Gauge-Type with Trip Odometer	Diesel Models	—	—	S	
		Gasoline Models	A	A	S	
	Warning Light Type	Tachometer	S	—	—	—
INSTRUMENT PANEL	Central Slide-Out Ashtray	Diesel Models	—	—	S	
		Gasoline Models	A	A	S	
	Cigarette Lighter	Colour-Keyed Energy-Absorbing Pad	A	S	S	S
	Right-Hand Storage Compartment with Lock	Right-Hand Storage Compartment with Lock	S	S	S	S
INTERIOR LAMPS	Ashtray Lamp and Stowage Box Lamp	A(9)	S	S	S	
	Courtesy Lamp (includes door-operated switches except on Sierra Conventional Cab)	S	S	S	S	
MIRRORS	Dome Lamp	Conventional Cab (includes door-operated switches on Sierra)	A	S	S	
		Club Coupe	S	S	S	
	Dual Black Exterior, Conventional Type (RH mirror is convex)	Dual Black Exterior, Below Eyeline Type (RH mirror is convex)	S	S	S	S
	Dual Black Exterior, Below Eyeline Type (RH mirror is convex)	Dual Chromed Exterior, Below Eyeline Type (RH mirror is convex)	A	A	A	—
Interior Rearview, Prismatic Type	Interior Rearview, Prismatic Type	S	S	S	S	
Interior Right-Hand Visor	Interior Right-Hand Visor	A	A	S	S	
POWER DOOR LOCKS/ WINDOWS	Available Separately or Together in Operating Convenience Package	A	A	A	A	
RADIOS/SPEAKERS (radios include mast-type antenna with black chrome finish)	With Digital Clock	AM/FM Monaural (UL7)	A	A	A	
		AM/FM Electronic-Tuned Stereo (UL1)	A	A	A	
	Without Clock	AM/FM Electronic-Tuned Stereo with Cassette Tape Player, Seek/Scan Feature, and Premium Speakers (UM6)	A	A	A	A
		AM/FM Electronic-Tuned Stereo with Cassette Tape Player, Seek/Scan and Graphic Speaker Equalizer Features, and Premium Speakers (UX1)	A	A	A	A
	Premium Rear Speakers for UL1/UJ9 Radios	AM Monaural (U63) or AM/FM Monaural (U69)	A	A	A	A
		AM/FM Electronic-Tuned Stereo (UJ9)	A	A	A	A
SEATS/SEAT BELTS	Full-Foam 3-Passenger Front Bench with Folding Backrest and Inertia Latches (includes outboard retractable lap/shoulder belts and manual centre lap belt)	Conventional Cab	S	S	—	
		Club Coupe	S	—	—	
SIDE RAILS	Full-Foam High-Back Front Buckets with Folding Backrests and Inertia Latches (easy entry feature on Club Coupe RH seat)	Conventional Cab	A	A	A	
		Club Coupe	A	A	S	
SPARE WHEEL/TIRE CARRIER	Reclining Feature for Bucket Seat Backs (Club Coupe only)	Conventional Cab	A	A	A	
		Club Coupe	A	A	S	
STEERING WHEEL/COLUMN	Rear Folding Jump Seats with Lap Belts (Club Coupe with bucket seats only)	Chromed; Mounted Atop Pickup Box Side Panels	A	A	A	
		Winch-Type; Mounted Under Frame at Rear	S	S	S	
SUNSHADES	Energy-Absorbing Column with Anti-Theft Locking	Black	S	—	—	
		Colour-Keyed	—	S	S	
	Two-Spoke Soft Plastic Wheel	Standard (Black)	S	—	—	
		Deluxe (colour-keyed)	—	S	S	
SUNSHADES	Sport (colour-keyed)	—	—	—		
		Comfortilt Type Steering Wheel to Match Above Wheels	A	A	A	
STORAGE CONSOLE	Colour-Keyed Padded	LH Sliding/RH Regular	S	—	—	
		LH/RH Sliding	—	S	S	
WINDSHIELD WIPERS/WASHERS	Colour-Keyed Plastic with Key Lock (requires bucket seats)	Electric; Two-Speed Wipers; Fluidic Washer Nozzle	S	S	S	
		Electric; Two-Speed Wipers with Intermittent Wipe Feature; Fluidic Washer Nozzle	A	A	A	
OTHER EQUIPMENT (See "How to Order Guide" for details.)						

5- Part of optional rear jump seats.
6- Part of optional air conditioning.
7- Concealed coin holder substituted on Sierra Classic and Gypsy LH door.
8- Requires optional 2-tone paint.
9- Part of optional auxiliary lighting package.
10- Part of optional Cold Climate Package.

Gasoline and Diesel Power

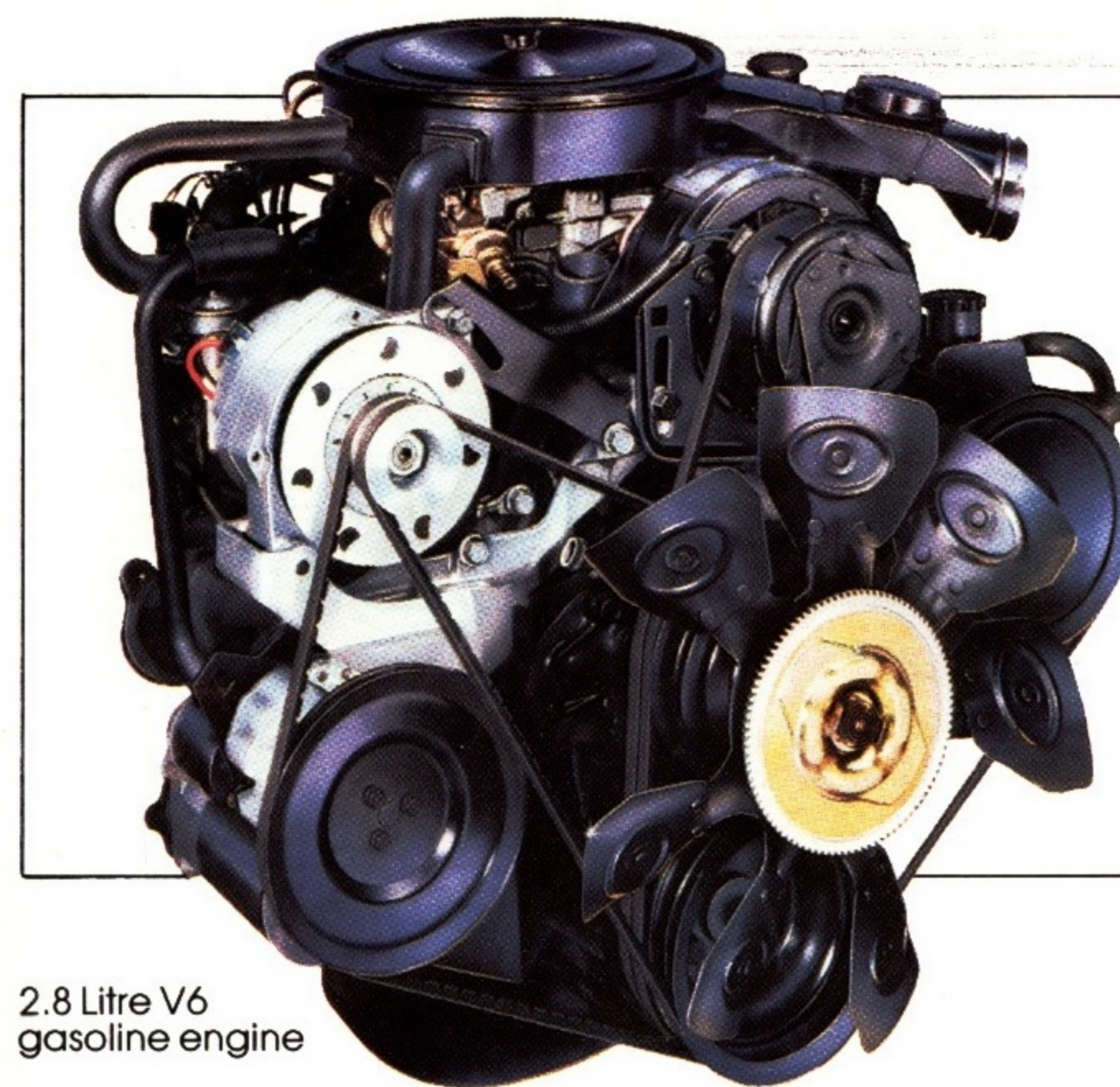

2.8 Litre V6 gasoline engine



1.9 Litre L4 gasoline engine

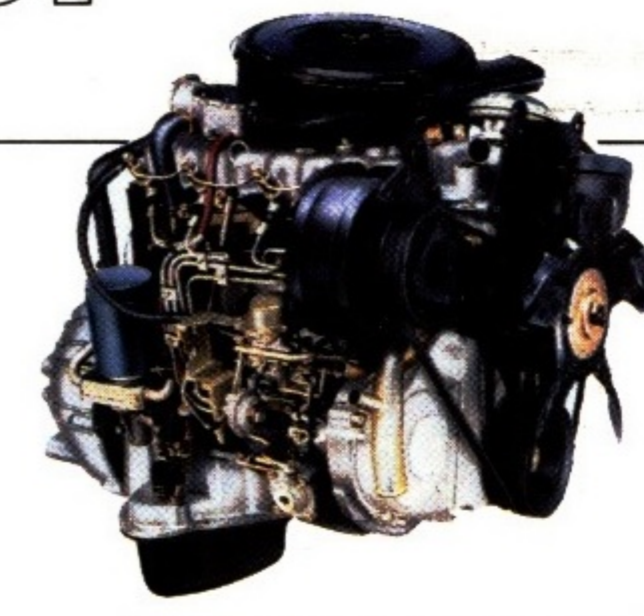

2.2 Litre L4 diesel engine

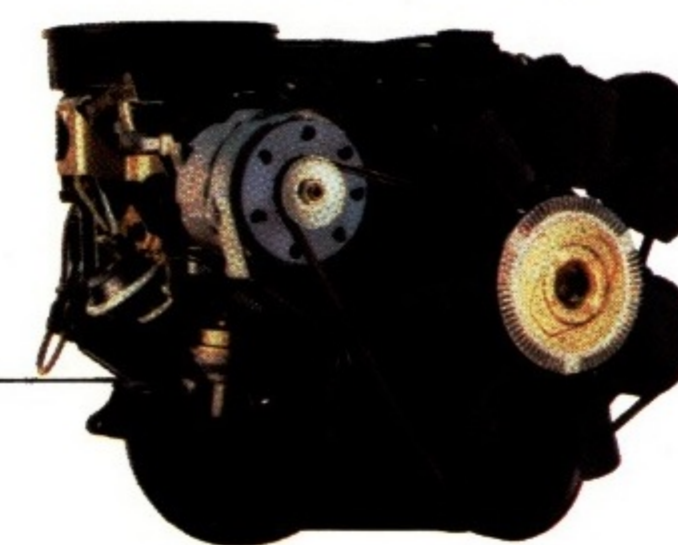

New 2.5 Litre L4 gasoline engine

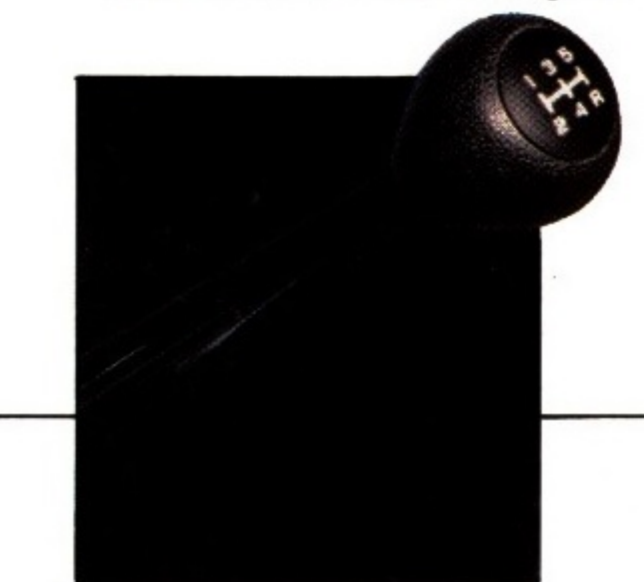

Available 5-speed manual transmission with overdrive

2.8 LITRE V6

The standard engine for all gasoline-powered models is the 2.8 Litre V6. It's an economical, smooth-operating engine with 115 horsepower and 150 lb/ft torque to move large payloads efficiently. Included with this engine is a 2.8 Litre V6 emblem on the vehicle front end.

NEW 2.5 LITRE IN-LINE 4

This new 4-cylinder engine is available for all gasoline-engine S-15 models, but not on Conventional Cab Pickups with the 737-kg (1625-lb) payload rating nor on Cab & Chassis models with the 2087-kg (4600-lb) GVW rating. The 2.5 L4 features a computer-controlled electronic fuel injection system. An available air cleaner pre-cleaner can be ordered with this engine.

1.9 LITRE IN-LINE 4

This high-mileage 4-cylinder engine is available for short-wheelbase 2-WD gasoline engine S-15 Conventional Cab Pickups with the standard 454-kg (1000-lb) payload rating only. It's an overhead-cam design engine with a 2-barrel carburetor and transistorized ignition.

2.2 LITRE IN-LINE 4 DIESEL

This engine is used for 2-WD S-15 Conventional Cab and Club Coupe Pickup diesel engine models. These models display a DIESEL 2.2 emblem on the vehicle front end.

S-15 TRUCK TRANSMISSIONS

4-speed fully synchronized manual transmission with automatic-adjusting hydraulic clutch control, standard on all S-15 models. With new available 2.5 Litre L4 engine, transmission includes an upshift light on the instrument panel to indicate when transmission should

be upshifted for the best compromise between vehicle performance and fuel economy. For further information on S-15 transmission availability, refer to the technical data chart on the back cover.

ENGINE TECHNICAL DATA

Engine Type	Gasoline		Diesel	
	1.9 Litre** 2-bbl L4	2.5 Litre+ EFI L4	2.8 Litre* 2-bbl V6	2.2 Litre** L4
Engine Ordering Code	LR1	LN8	LR2	LQ7
Bore and Stroke, Mm (In)	86.87 x 82.04 (3.42 x 3.23)	101.6 x 76.2 (4.00 x 3.00)	88.90 x 75.95 (3.50 x 2.99)	88.0 x 92.0 (3.46 x 3.62)
Compression Ratio	8.4:1	9.0:1	8.5:1	21:1
SAE Net Horsepower @ RPM	82 @ 4600	92 @ 4400	115 @ 4800	62 @ 4300
SAE Net Torque Lb/Ft @ RPM	101 @ 3000	134 @ 2800	150 @ 2100	96 @ 2200
VIN++	A	E	B	S

EFI=Electronic Fuel Injection
* Produced by GM, Chevrolet Motor Division
** Produced by Isuzu Motors Limited, Japan
+ Produced by GM, Pontiac Motor Division
++ The V.I.N. (Vehicle Identification Number) Engine Code is the eighth entry (letter or numeral) from the left on the vehicle serial number plate. The vehicle serial number plate is located on the top portion of the driver's side of the instrument panel and can be viewed from the exterior of the vehicle by looking through the windshield.

A WORD ABOUT ENGINES

Some GMC Light Duty trucks are equipped with engines produced by other GM divisions, subsidiaries, or affiliated companies worldwide. See your dealer for details.

A WORD ABOUT ASSEMBLY, COMPONENTS, AND OPTIONAL EQUIPMENT IN THESE VEHICLES

The GMC vehicles described in this brochure are assembled at various Divisions of General Motors Corporation. These vehicles incorporate thousands of different components produced by General Motors of Canada Limited and related companies and their suppliers. From time to time during the manufacturing process, it may be necessary, in order to meet public demand for particular vehicles or equipment, or to meet federally mandated emission and safety requirements or fuel economy guidelines, or for other reasons, to produce vehicles with different components or differently sourced components than initially scheduled. All such components have been approved for use in our products by General Motors of Canada Limited or related companies and will provide the quality performance associated with our name.

Please note that certain optional equipment can be ordered only in conjunction with other optional equipment.

Also, upgrading from specified standard equipment may be necessary when certain optional equipment is ordered. Ask your sales representative for details.

With respect to extra-cost optional equipment, make certain you specify the type of equipment you desire on your vehicle when ordering if from your dealer. Some options may be unavailable when your truck is built. Your dealer receives advice regarding the current availability of options. You may ask the dealer for this information. GM also requests the dealer to advise you if an option you ordered is unavailable. We suggest that you verify that your truck includes the optional equipment you ordered or, if there are changes, that they are acceptable to you.

These vehicles also are available under the Chevrolet nameplate (Series S-10 Regular Cab Pickup, Extended Cab Pickup, and Chassis-Cab).

PAINT SCHEMES

Solid-colour paint is standard on all models, except Gypsy. Available body-side striping can be ordered on Sierra and High Sierra models.

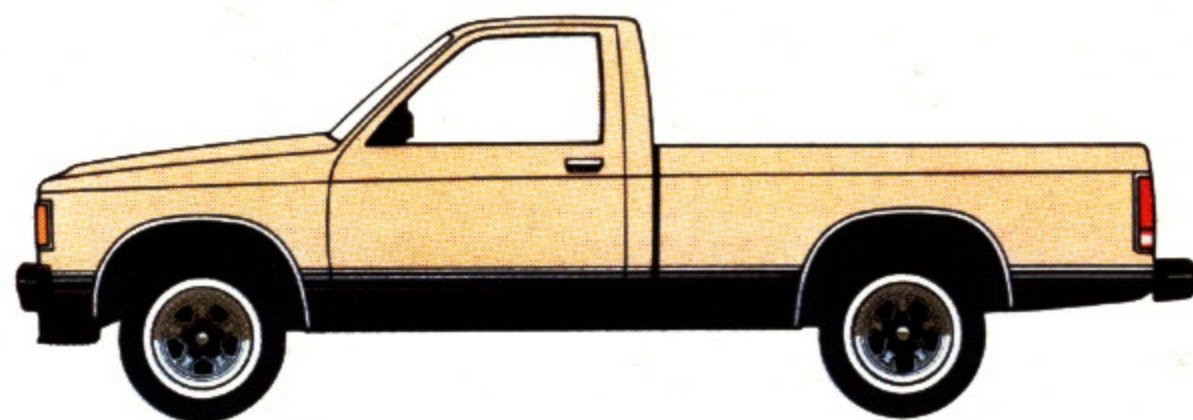

Sport Two-Tone paint scheme (standard on Gypsy models) extends accent colour around to front and rear bumpers.

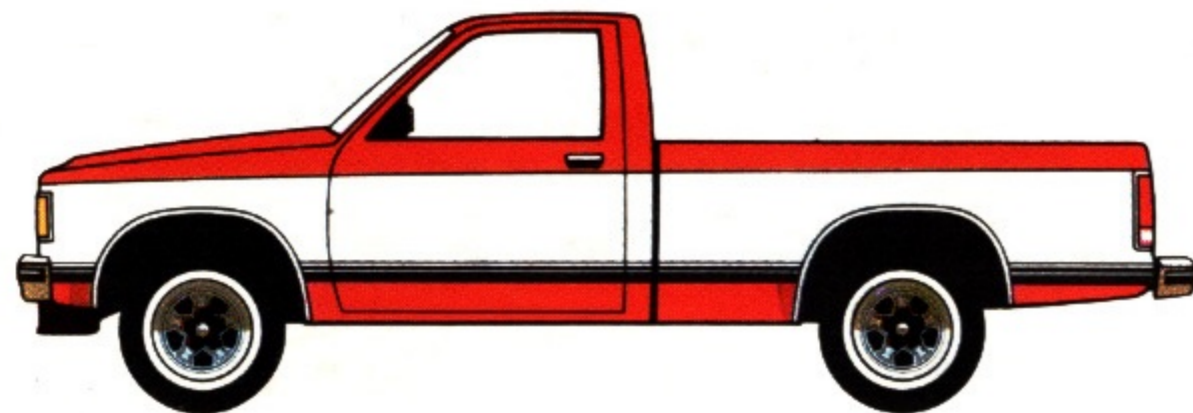

Special Two-Tone paint scheme for all models except Gypsy extends middle accent colour around front and rear.

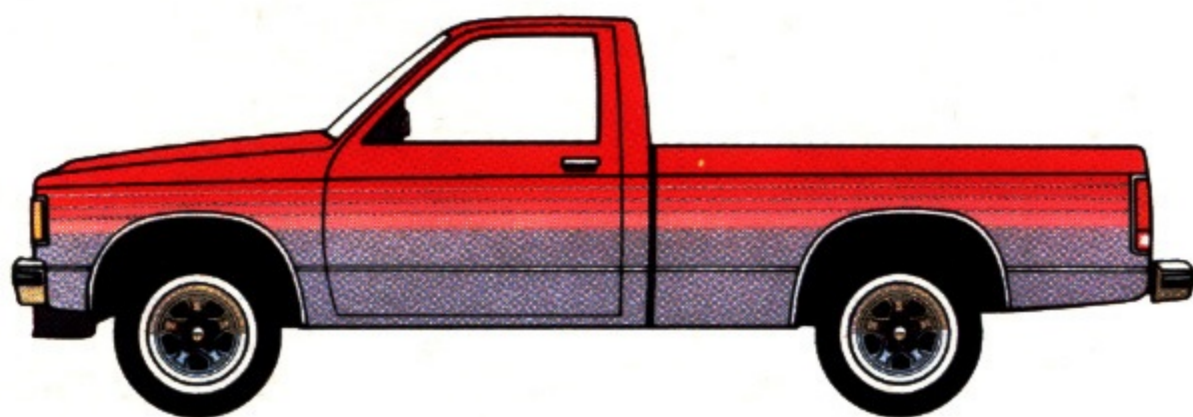

New Custom Two-Tone paint scheme for all models includes body striping in selection of five colours.

TECHNICAL INFORMATION

PICKUP MODEL TYPE	GASOLINE ENGINE						DIESEL ENGINE			
	2-wheel			4-wheel			2-wheel			
DRIVE TYPE	conventional			club coupe	all	all	all	all		
CAB TYPE	2750 (108.3)	2997 (117.9)	3122 (122.9)	all	all	all	all	all		
WHEELBASE, MM(IN)	454 (1000)			680 (1500)	737 (1625)(A)	454 (1000)	680 (1500)	454 (1000) 567 (1250)		
PAYLOAD RATING, KG(LB)	454 (1000)			680 (1500)	737 (1625)(A)	454 (1000)	680 (1500)	454 (1000) 567 (1250)		
ENGINE/TRANSMISSION AVAILABILITY										
1.9L/4-speed manual	avail	—	—	—	—	—	—	—	—	
2.5L/4-speed manual	avail	avail	avail	avail	—	avail	avail	—	—	
2.5L/5-speed manual overdrive	avail	avail	avail	avail	—	avail	avail	—	—	
2.5L/4-speed automatic overdrive	avail	avail	avail	avail	—	avail	avail	—	—	
2.2L/4-speed manual	—	—	—	—	—	—	—	std	std	
2.2L/5-speed manual overdrive	—	—	—	—	—	—	—	avail	avail	
2.8L/4-speed manual	std	std	std	std	std	std	std	—	—	
2.8L/5-speed manual overdrive	avail	avail	avail	avail	avail	avail	avail	—	—	
2.8L/4-speed automatic overdrive	avail	avail	avail	avail	avail	avail	avail	—	—	
FRONT SUSPENSION	independent, coil springs (2-WD)/torsion bars (4-WD)									
Capacity, kg(lb)	1134 (2500)			1224 (2700)			1134 (2500)			
Spring capacity, kg(lb)(B)	567 (1250)			612 (1350)			567 (1250)			
Shock absorber diameter, mm(in)	25 (1.00)			25 (1.00)(C)			25 (1.00)			
Stabilizer bar diameter, mm(in)	avail: 25 (1.00)			std: 25 (1.00)			std: 32 (1.26) avail: 25 (1.00) std: 25 (1.00)			
REAR SUSPENSION	salisbury axle, leaf springs									
Axle capacity, kg(lb)	1179 (2600)			1224 (2700)			1179 (2600)			
Spring capacity, kg(lb) (B)	521.5 (1150)			612.3 (1350)			521.5 (1150) 612.3 (1350) 521.5 (1150) 612.3 (1350)			
Shock absorber diameter, mm(in)	std: 25 (1.00); avail: 32 (1.26)									
BRAKES	hydraulic, front disc/rear drum									
Vacuum booster	avail	std	std	std	std	std	std	std	std	
Parking	cable to rear wheels									
STEERING	std: manual; avail: power						power(D)		power	
TIRES, RADIAL PLY	Standard (F)	P195/75R14(E)				P195/75R15		P195/75R14		
	Available	large selection of highway/on-off road tires (consult your GMC Dealer)								
FUEL TANK CAPACITY, LITRES (IMP. GALLONS)	Standard	50 (11)						58 (12.7)		
	Available	76 (16.7)						76 (16.7)		
FREEDOM BATTERY, CCA	std: 315 (1.9L L4), 500 (2.8L V6), 515 (2.5L L4); avail: 515 (1.9L/2.8L)						770			
GENERATOR, AMPS	std: 56; avail: 66						66			

CCA = Cold Cranking Amps
A - Conventional cab only.
B - At ground, each.
C - 32 mm (1.26") available.

D - Manual available.
E - P205/75R14 for 737 kg (1625 lb) payload.
F - All Seasons type.

EXTERIOR COLOURS

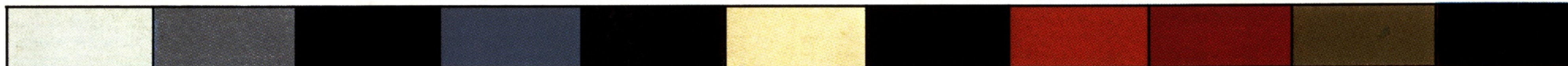

Frost White Silver Metallic Midnight Black Light Blue Metallic Galaxy Blue Metallic Doeskin Indian Bronze Metallic Cinnamon Red Apple Red Desert Sand Metallic Satin Black

Note: Satin Black is accent colour only for Sport Two-Tone paint option. For accurate colours, ask your GMC Dealer to show you actual paint colour chips.

GMC Canada
Trucks are what we're all about

All illustrations and specifications contained in this catalogue are based on the latest product information available at time of publication approval. The right is reserved to make changes at any time, without notice, in prices, colours, materials, equipment, specifications and models, and to discontinue models. Some of the equipment shown or described throughout this catalogue is available at extra cost. Check with your dealer for complete information.

GM
Canada

Official Supplier
to The 1986
World Exposition

EXPO
86

6163-85CA Eng.
Litho in USA