



The Next

# 05 F-250/F-350 SUPER DUTY



INTRODUCING  
**THE NEXT  
 F-SERIES**



King Ranch

XL

Lariat

XLT

Ford Harley-Davidson™ F-Series

**2005 Ford F-250/F-350 Super Duty**

<b>Best Power</b> New Triton™ 3-Valve V8 and V10 Gas Engines 6.0L 32-Valve Power Stroke® V8 Turbo Diesel TorqShift™ 5-Speed Automatic Transmission	<b>03</b>
<b>Stronger 4x4</b> New Twin-Coil Monobeam Front Suspension Improved Turning Diameter	<b>07</b>
<b>Best Payload</b> Stronger Frame and Higher Maximum GAWR Maximum Payload Capability – 5800 lbs.	<b>11</b>
<b>Best Towing</b> First Integrated Trailer Brake Controller Maximum Conventional Towing – 15,000 lbs. Maximum 5th-Wheel Towing – 17,000 lbs.	<b>15</b>
<b>Best Interior Space</b> Most Interior Room	<b>19</b>
<b>Best Trucks</b>	<b>21</b>
<b>F-250/F-350 XLT</b> Chrome Accents and Cloth Interior Monochromatic XLT Sport and Leather Options	<b>23</b>
<b>F-250/F-350 Lariat</b> Extensive Standard Equipment Premium Leather Interior Trim Accents	<b>25</b>
<b>F-250/F-350 King Ranch</b> King Ranch "Branded" Appointments Castaño Leather Interior Trim Accents	<b>27</b>
<b>F-250/F-350 Harley-Davidson™</b> 20" Forged-Aluminum Wheels Available Painted Flames	<b>29</b>
<b>Specifications</b> Standard and Available Features Payload and Towing Capabilities	<b>31</b>

INTRODUCING  
**THE NEXT  
F-SERIES**

# SUPER DUTY



The new 2005 F-Series Super Duty has arrived. It's the boldest, strongest and most capable yet, with hauling and towing capacities that set new limits for the class.\* Outside, the fat bar grille announces a muscular new look. Inside, there's the most passenger room in every cab type for hard-working crews. And underneath it all, stronger engines, chassis and 4x4 front suspension mark a new era of Super Duty performance. One measured against the most powerful standard in trucks: Built Ford Tough. A standard that has made Ford F-Series the best-selling trucks for 27 straight years.

## BEST-IN-CLASS

- BEST HORSEPOWER
- BEST GAS TORQUE
- UNSURPASSED DIESEL HORSEPOWER
- MOST PULLING POWER
- LONGEST-LASTING\*\* DIESEL ENGINE
- BEST BRAKING PERFORMANCE
- HIGHEST GVWR
- BEST PAYLOAD
- UNSURPASSED GCWR
- BEST CONVENTIONAL TOWING
- BEST 5TH-WHEEL TOWING
- MOST INTERIOR ROOM

## FIRST-IN-CLASS

- FULLY INTEGRATED TRAILER BRAKE CONTROLLER
- 15,000-LB.-RATED 2-1/2" HITCH RECEIVER
- UPFITTER SWITCHES
- "DRIVER'S" GLOVE COMPARTMENT

## CLASS EXCLUSIVES

- NEW 5.4L TRITON™ V8 – 3-VALVE WITH VARIABLE CAM TIMING
- NEW 6.8L TRITON V10 – 3-VALVE WITH SEFI
- FORD HARLEY-DAVIDSON™ F-SERIES SUPER DUTY
- FORD KING RANCH F-SERIES SUPER DUTY
- POWER MOONROOF

\*Class is Full-size Pickups over 8500 lbs. GVWR.  
\*\*Based on vehicles in operation, 1994-CYTD, June 2004.

# BEST POWER

## ■ Triple Threat

Engine Choice – With 362 hp and 457 lb.-ft. of torque, the new 6.8L 3-valve Triton™ V10 is the most powerful gas engine in the class. The 6.0L Power Stroke® V8 Turbo Diesel delivers unsurpassed diesel horsepower and, thanks to 570 lb.-ft. of massive twist, the most diesel pulling power. Even the standard power plant is a 5.4L Triton V8 with new 3-valve heads and variable cam timing. It pumps out 300 hp and 365 lb.-ft. of torque.



### ■ Longest-Lasting Diesel

**Cast-Iron Block and Head** – This proven architecture withstands the higher combustion pressures of peak diesel operation. The stiff bedplate provides rigidity. Electro-Hydraulic Direct Injection (EHD), 4-valve induction and electronic engine control promote efficient combustion for optimized horsepower and torque. All together, the 6.0L Power Stroke is the longest-lasting diesel in its class.\*

\*Based on vehicles in operation, 1994-CYTD, June 2004.

### ■ Turbo-Flex Performance

**Electronic Variable Response Turbocharger (EVRT™)** – The turbo blades automatically adjust to optimize the airflow and provide fast torque response. That delivers impressive grade-climbing capability, high-altitude performance and towing capacity. The system also helps minimize turbo lag and responds quickly to low-speed launch demands.

## POWER STROKE TURBO DIESEL V8

### ■ Transfer Of Power

**TorqShift™ 5-Speed Automatic Transmission** – Created specifically to handle the crushing torque of the 6.0L Power Stroke Turbo Diesel, TorqShift is now available with our gas engines as well. TorqShift uses direct electronic shift control in unison with the powertrain control module to precisely manage power delivery in any driving circumstance. When tow/haul mode is selected, engine speed, vehicle speed and other parameters are monitored to engage the right gear for towing and hauling conditions. The smooth-running TorqShift automatic is one very smart transmission that has earned the label: Built Ford Tough.



# POWER THAT WORKS

What good is power if you can't use it? It's useless. That's why we focus on creating usable power – Tractive Force – at the wheel. It's a total powertrain-system approach that pairs powerful engines with sturdy transmissions and strong axles geared to perform under real-world conditions. And it delivers best-in-class diesel pulling power in a 0-60 mph run-off against the best the competition offers. That's Ford Truck power leadership.

## F-350 XLT SUPER DUTY



### ■ Variable Cam Timing Optimizes V8 Power

**NEW 5.4L Triton™ V8** – 3-valve induction with variable cam timing uses 2 intake valves and a charge motion control valve to swirl a larger fuel charge into the combustion chamber, while a single large exhaust valve evacuates the burned gases. Cam timing is electronically controlled to optimize the entire process. Improved engine breathing is complex, but the results are easy to understand: more horsepower, higher torque and better fuel efficiency.

### ■ Maximum Available Gas Power

**NEW 6.8L 3-Valve Triton V10** – This new engine produces more horsepower and torque than any other gas engine in the class. Its Electronic Throttle Control delivers smooth, refined power. New 3-valve induction improves low-end torque and fuel efficiency. Couple it with the available TorqShift 5-speed automatic or 6-speed manual transmission, and you have class-leading payload and towing capacity in a gas powertrain.

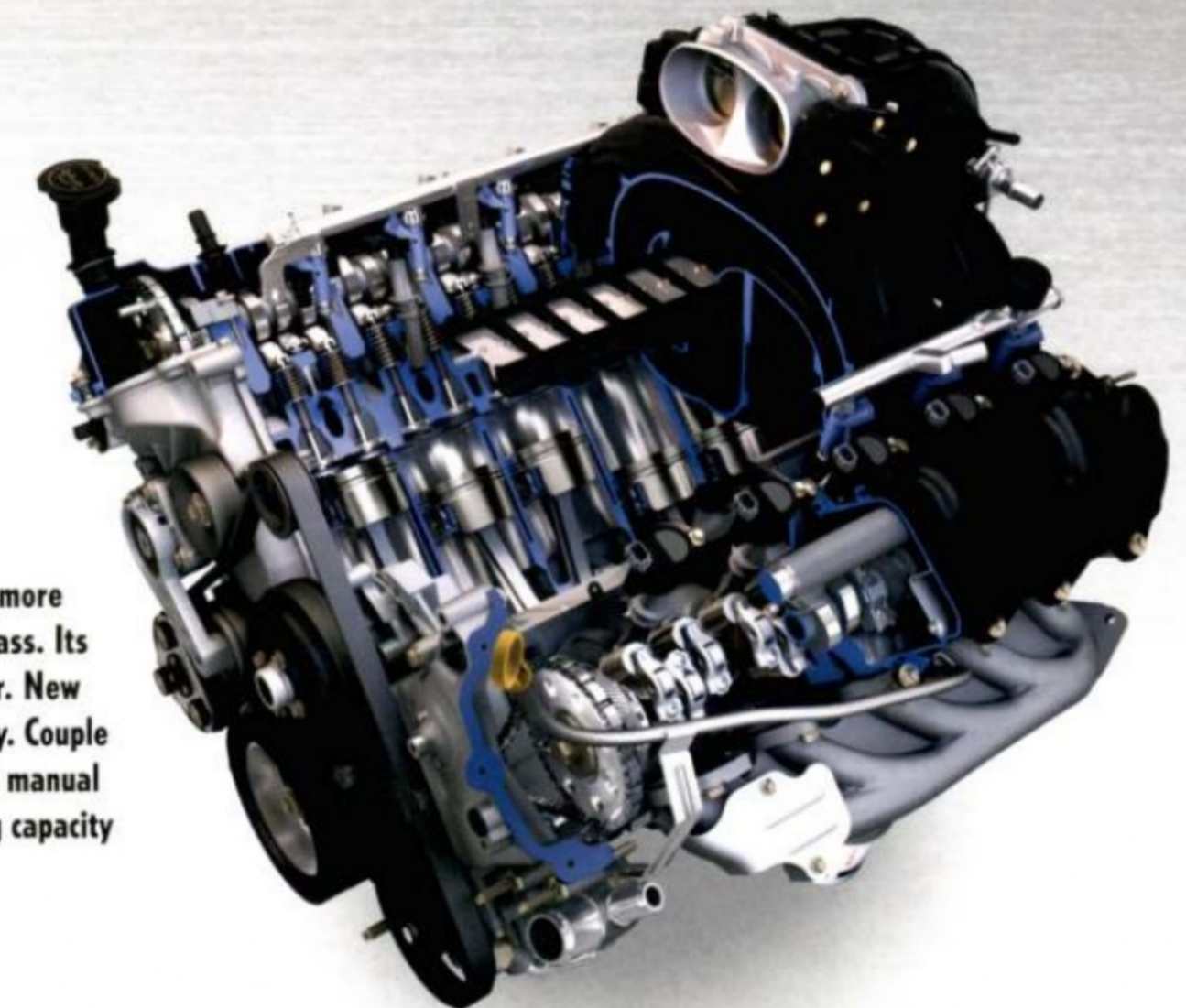



# STRONGER 4x4

■ **No 4x4 Works Harder**

When the work starts where the road ends, Super Duty is all business. An all-new 4x4 Twin-Coil Monobeam front suspension adds multiple benefits to Super Duty's legendary reputation for off-road toughness. The new system lets you turn tighter, handle more confidently, ride more comfortably, and it offers the highest maximum front GAWR in the class. For F-Series Super Duty, it's just another walk in the woods.



Twin-Coil Monobeam Front Suspension

### ■ Strong-Arm Tactic

Largest Suspension Control Arms – We use the same massive control arms as in the F-550 to anchor the axle to the frame, putting muscle where it's needed most. This solid architecture helps the new coil-spring setup deliver capable handling and a smooth ride in a rugged, heavy-duty 4x4 pickup.

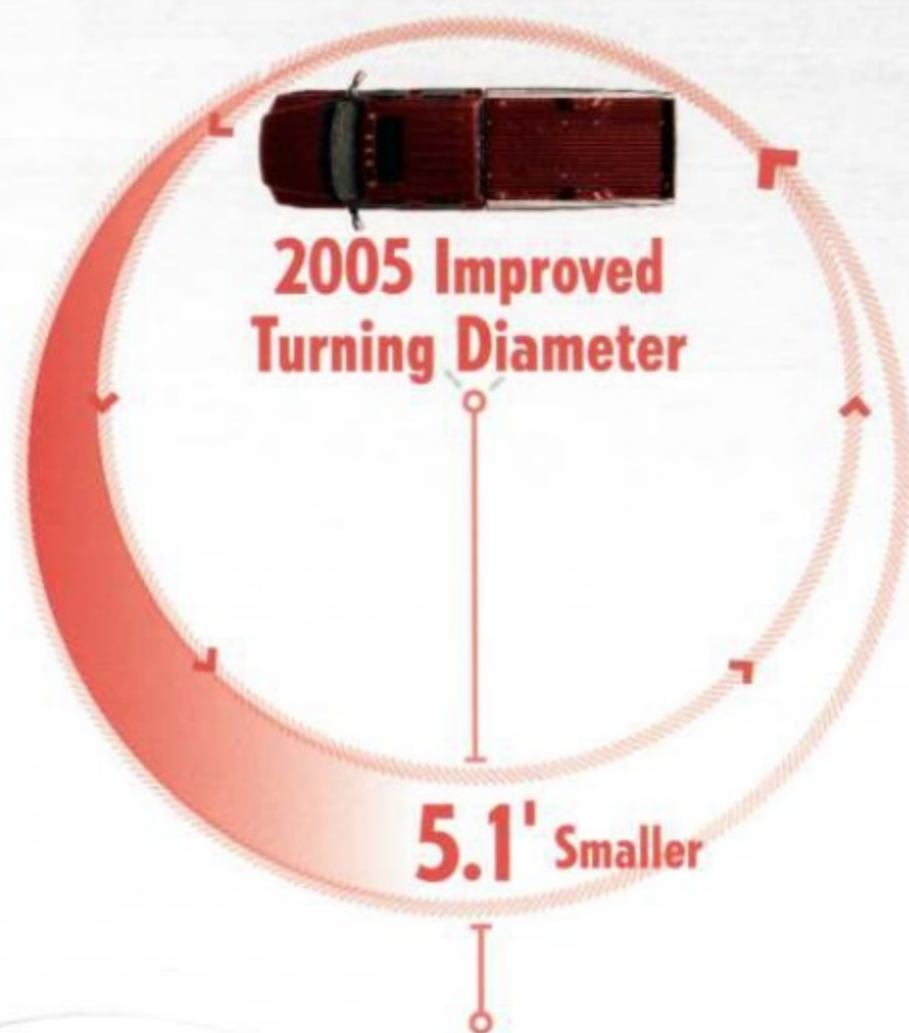

### ■ Precision Maneuvers

ALL-NEW 4x4 Front Suspension – An all-new design allows completely new geometry for one dramatic improvement after another. The Super Duty 4x4's turning diameter is up to 5.1' tighter than before; loaded and unloaded cornering and maneuverability are more precise; and it's easier to park, too.

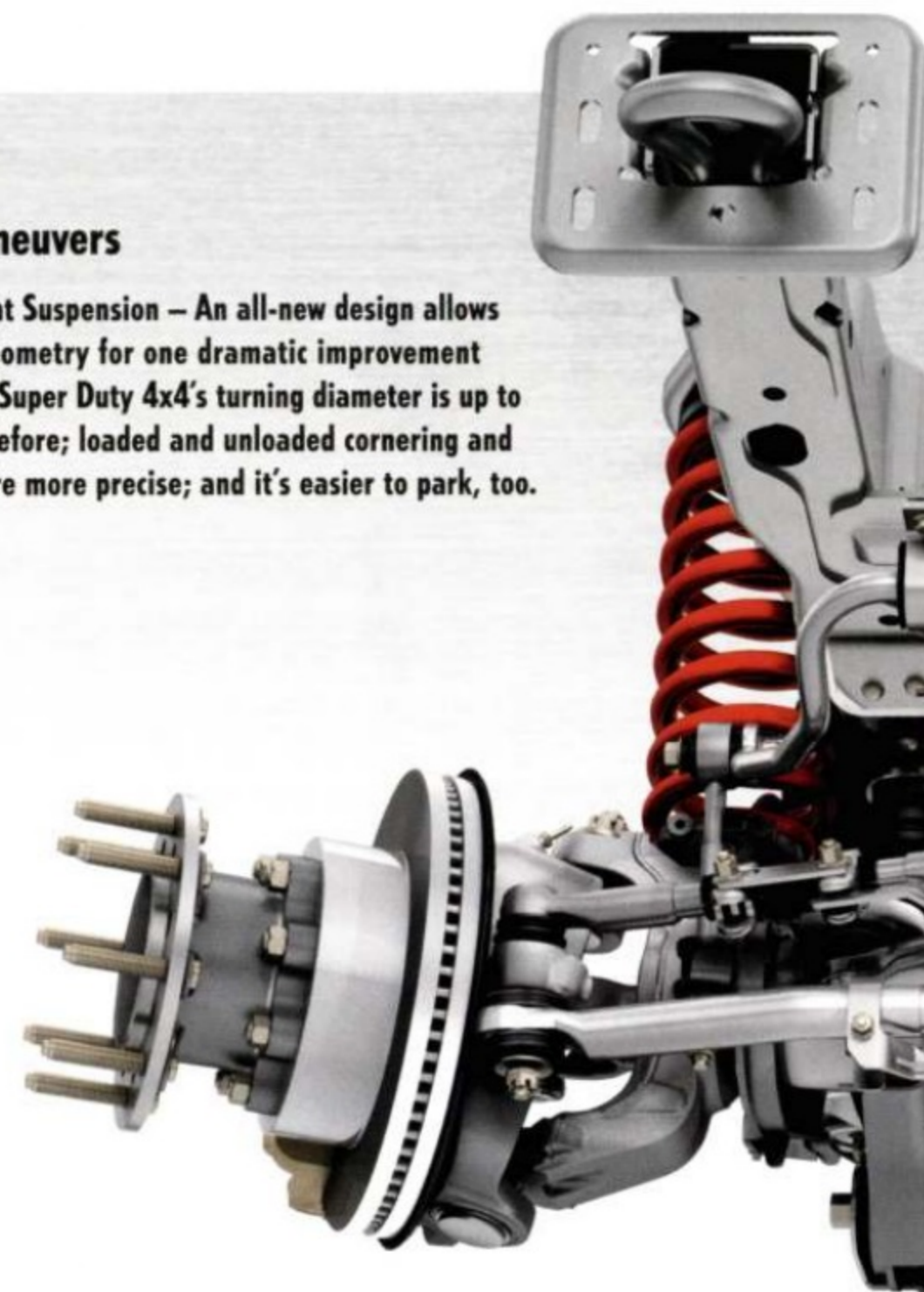

### ■ Stay The Course

ALL-NEW Steering System – The all-new system is more robust, with improved steering response, reduced parking effort and reduced 4x4 turning diameters. An improved steering damper reduces kickback off-road, while on the highway, it smoothes overall steering operation and helps maintain directional control.

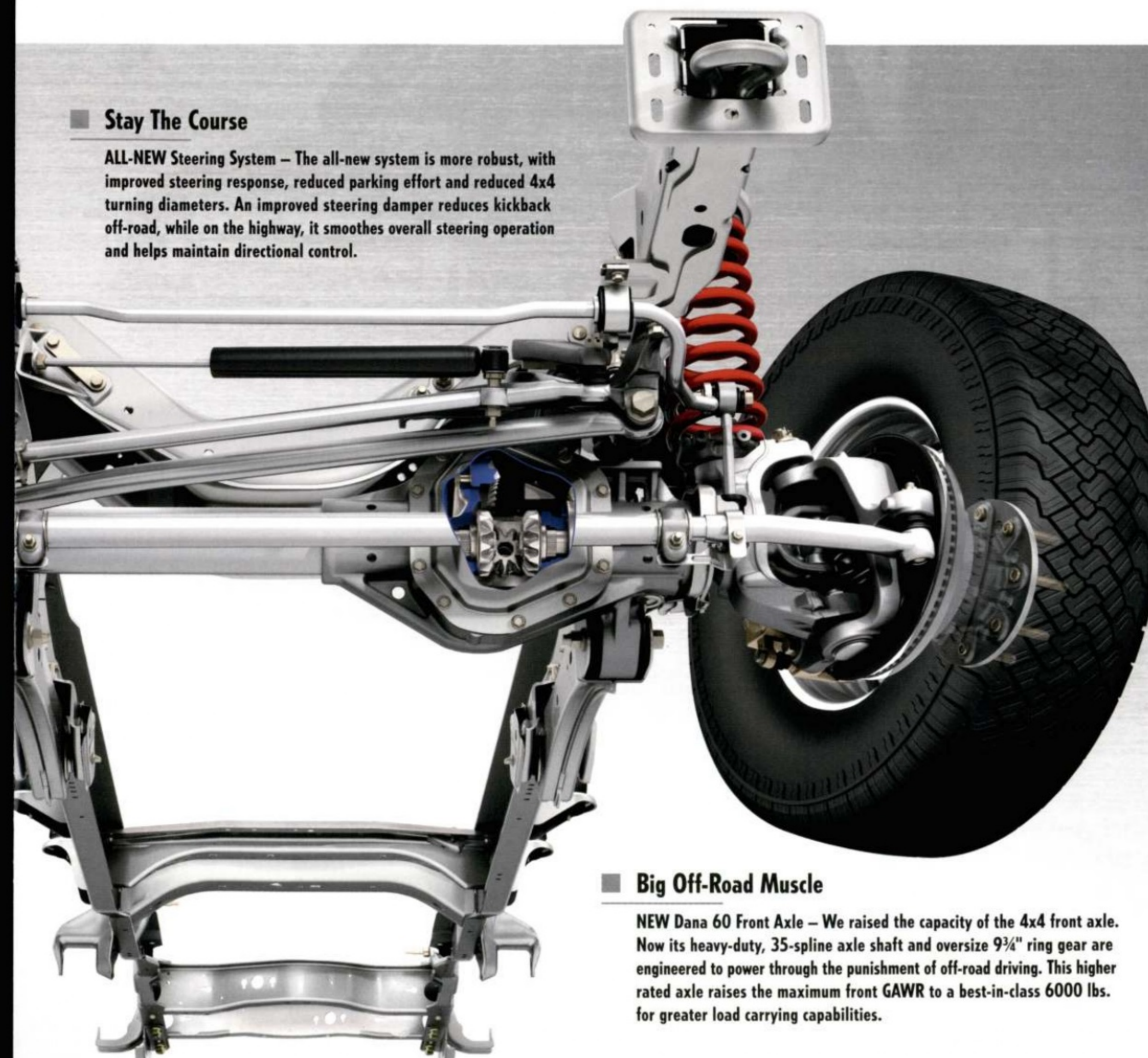

### ■ Tough, Tried And True

Automatic/Manual Locking Hubs – In addition to our available Electronic Shift-On-the-Fly (ESOF) system, Ford gives you the reassurance of a mechanical connection with manual locking hubs to help maintain 4x4 capability under rugged, off-road conditions. You may not need them often, but when they get you out of a tight spot, you'll be glad Ford provides them on your Super Duty.



### ■ Big Off-Road Muscle

NEW Dana 60 Front Axle – We raised the capacity of the 4x4 front axle. Now its heavy-duty, 35-spline axle shaft and oversize 9 $\frac{3}{4}$ " ring gear are engineered to power through the punishment of off-road driving. This higher rated axle raises the maximum front GAWR to a best-in-class 6000 lbs. for greater load carrying capabilities.



## BEST-IN-CLASS PAYLOAD

### Beast Of Burden

The Super Duty frame can take on the most payload in its class. So put a 5800-lb. load in the bed of a properly equipped Super Duty, and then haul it as far as the road will take you. The new 6.7-mil steel C-channel frame rails are made with the thickest steel in the class and feature the same architecture as the F-450/F-550. With standards like these, it's no wonder that more people use Ford F-Series to haul materials, tools and machinery than any other truck.



New 6.7-mil Steel C-Channel Frame





### ■ A Staggering Improvement

**ALL-NEW Rear Suspension** – The beefy new 3"-wide rear leaf springs and staggered rear shocks improve axle control, contributing to better ride and confident handling, loaded or empty. The new rear suspension delivers best-in-class payload and towing capability. And the revised rear shock placement helps control axle wind-up to enhance traction for improved acceleration and braking.

### ■ Thickest Steel Rails

**NEW 6.7-mil Steel C-Channel Frame** – The steel-rail gauge thickness increased between 10% and 17%, and frame strength went up along with it between 10% and 20%, depending on model. That's a much thicker gauge than the competition offers.

### ■ You Need To Stop Better, Too

**NEW Larger Brakes** – More payload capacity demands more stopping power. To deliver best-in-class braking performance, front and rear rotors and calipers have been up-sized and the brake system has new master cylinders. But the improvements don't stop there: Front and rear brake linings now last nearly 50% longer, and the new brakes are far quieter, too.

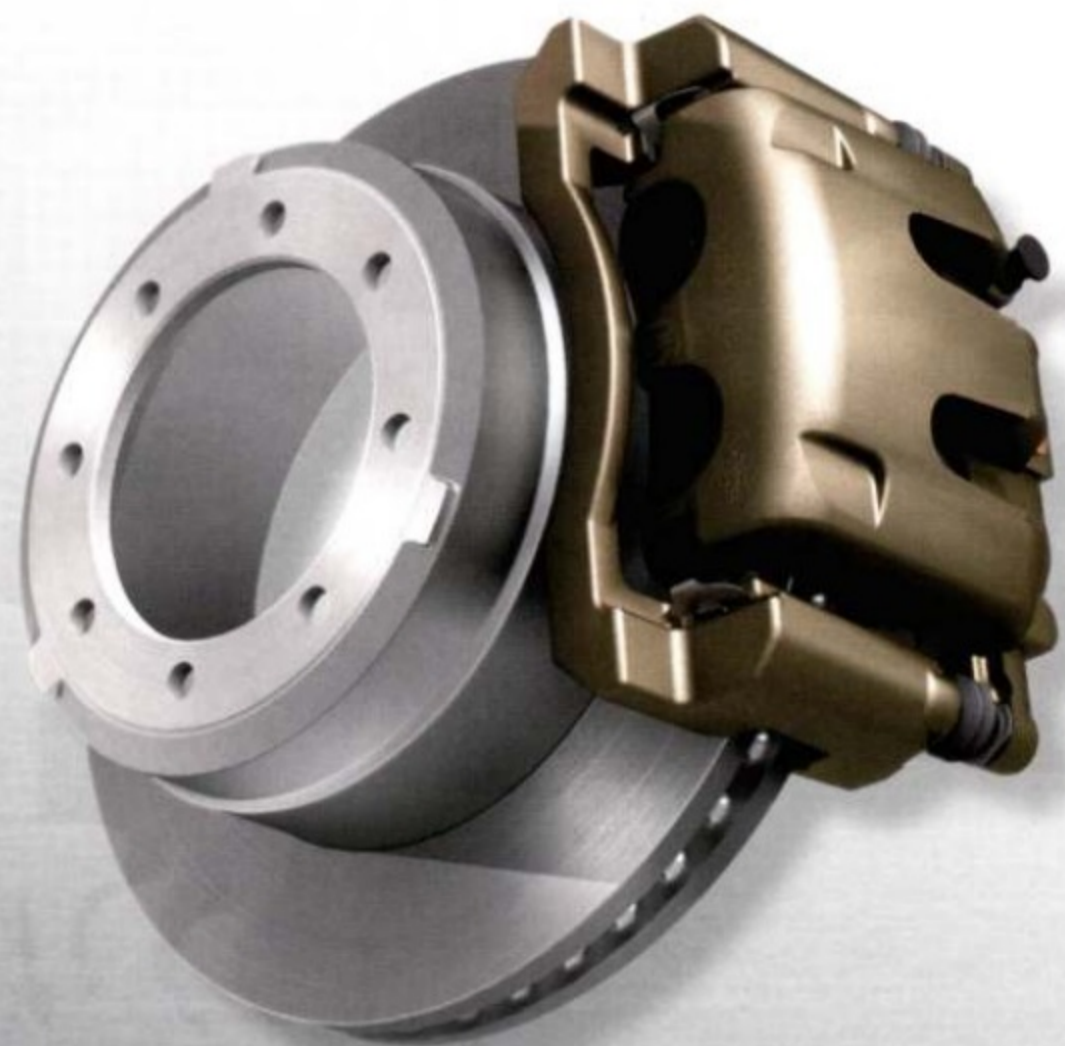

### ■ Stronger Body Mounts

**NEW MCU Body Mounts** – Long-lasting micro-cellular urethane (MCU) material was selected for the body mounts to help isolate the passenger cabin from noise, vibration and harshness over the long haul.

# BIGGER, STRONGER, TOUGHER

From the ground up, we've built strength upon strength to deliver best-in-class available payload capacity. It starts with the new thickest-in-class 6.7-mil steel C-channel frame. Then we bolt on bigger brakes, staggered shocks, 3"-wide leaf springs, an available 15,000-lb. rated 2½" trailer hitch receiver and new 17" and 18" wheels. Nothing less would do for The Next F-Series Super Duty.

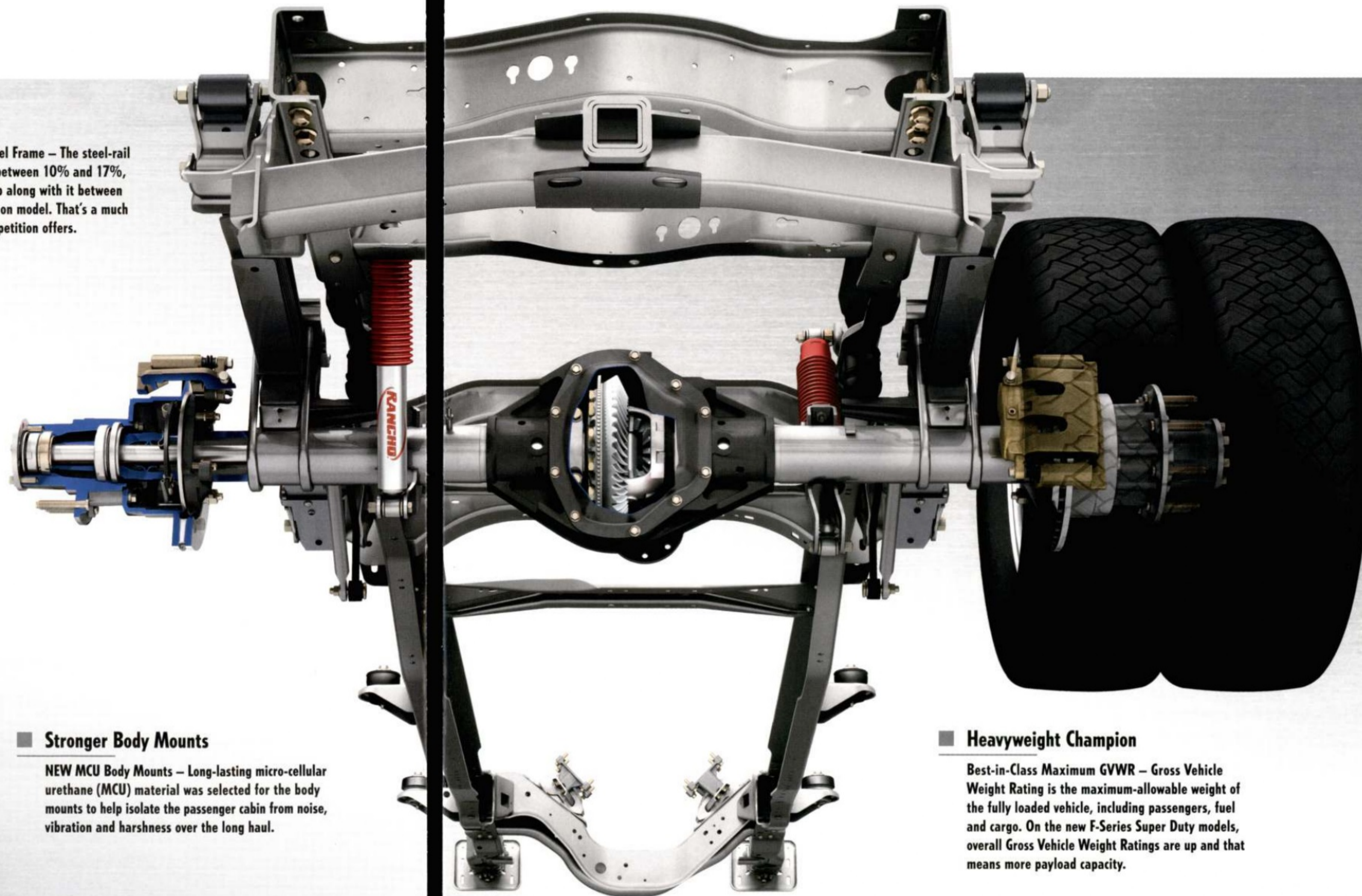

### ■ Heavyweight Champion

**Best-in-Class Maximum GVWR** – Gross Vehicle Weight Rating is the maximum-allowable weight of the fully loaded vehicle, including passengers, fuel and cargo. On the new F-Series Super Duty models, overall Gross Vehicle Weight Ratings are up and that means more payload capacity.



# BEST-IN-CLASS TOWING

## Any Bigger, And You'll Have To Go Pro

Not only does Ford provide powerful engines, smart transmissions, strong chassis components, and the only fully integrated Trailer Brake Control system in the class, but it tops the competition in braking performance and pulling power to boot. All this performance adds up to best-in-class conventional and 5th-wheel towing capacity. Hitch up to 17,000 lbs. with a properly equipped Super Duty and drive away. If you want to pull more weight, you'll probably need a commercial operator's license.



First-and-Only Fully Integrated Trailer Brake Controller

# INTRODUCING TOWCOMMAND

This fully integrated, factory-installed towing system is designed to help keep you in control of your Super Duty truck when towing. The available system starts with the first fully integrated Trailer Brake Controller **A**. Then it integrates ABS with best-in-class braking performance **B**, the TorqShift automatic transmission with tow/haul mode **C** and telescoping trailer tow mirrors **D**. When activated, this system works invisibly to make your towing task seem effortless. Along with it comes the added peace of mind of knowing you have the most-sophisticated, factory-installed towing system available.

**BEST-IN-CLASS  
CONVENTIONAL TOWING**  
UP TO **15,000 LBS.**

Engines: 6.0L Power Stroke V8 Turbo Diesel  
6.8L 3-Valve Triton V10

Transmissions: 6-Speed Manual  
TorqShift 5-Speed Automatic

Drivetrain: DRW 4x2/4x4

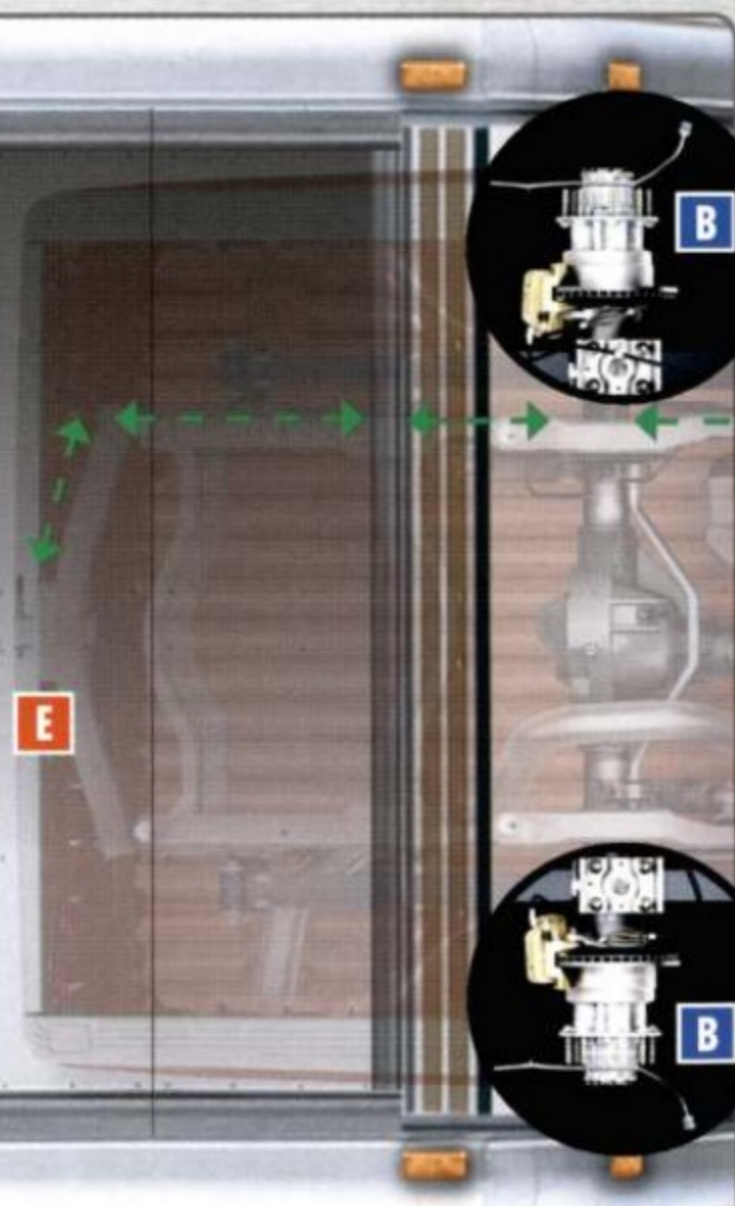

## **B** Big Brakes, Smart Stops

**Standard ABS** – The large disc brakes are enhanced by an Anti-lock Brake System. The system communicates with the optional integrated Trailer Brake Controller and helps you control the vehicle in hard braking situations.



**BEST-IN-CLASS  
PULLING POWER  
WINNER**

Power Stroke V8 Turbo Diesel – F-Series Super Duty outpulls the competition from a dead stop in a 0-60 mph tow-off. It's done through careful powertrain management, from engine to gearing to wheels and tires. The result is more-capable trucks.

**BEST-IN-CLASS  
5TH-WHEEL TOWING**  
UP TO **17,000 LBS.**

Engine: 6.8L 3-Valve Triton V10

Transmission: TorqShift 5-Speed Automatic

Drivetrain: SRW 4x2

## **D** Expand Your View

**Telescoping Trailer Tow Mirrors** – Extra-large mirrors are included in the available TowCommand Package and give you an extended field of view that's especially useful when towing a king-size 5th-wheel trailer. Power, heated glass and integrated clearance lamps and turn signals are included on XLT and Lariat.



## **C** Ultimate Power Management

The remarkable TorqShift 5-Speed Automatic transmission features a selectable tow/haul mode. Its sophisticated electronic controls sense towing and hauling demands and adjusts its operation to meet them. When hauling a heavy load or trailer, the tow/haul mode helps reduce gear hunting, improves power delivery, and even uses engine braking to help control vehicle speed when descending hills.



## **E** Super-Hitch Option

**NEW 15,000-lb.-Capable 2.5" Hitch Receiver** – If you need maximum capability, look no further. The biggest, most-capable hitch in the class is available on F-350 dual-rear-wheel models with 6.8L Triton™ V10 or 6.0L Power Stroke® V8 Turbo Diesel engines. With it comes the ability to tow more than ever before. There's even a convenient 2" receiver adapter for hauling trailers up to 12,500 lbs.



# FORD EXCLUSIVE

F-Series introduces the first factory-installed Trailer Brake Controller (TBC) **A** that is fully connected to the vehicle computer network. That means it can read driver braking activity from the Super Duty Anti-lock Brake System **B**, and provide proportional trailer braking to match. It uses master-cylinder pressure, vehicle speed, even whether or not ABS is on or off, to adjust trailer-brake performance. Panel indicators provide a wealth of information, including trailer connection status, output level, gain level, and vehicle message center warnings and even a trailer disconnect alarm. All of these features offer you a decided towing advantage on the road.

# TRAILER BRAKE CONTROL SYSTEM

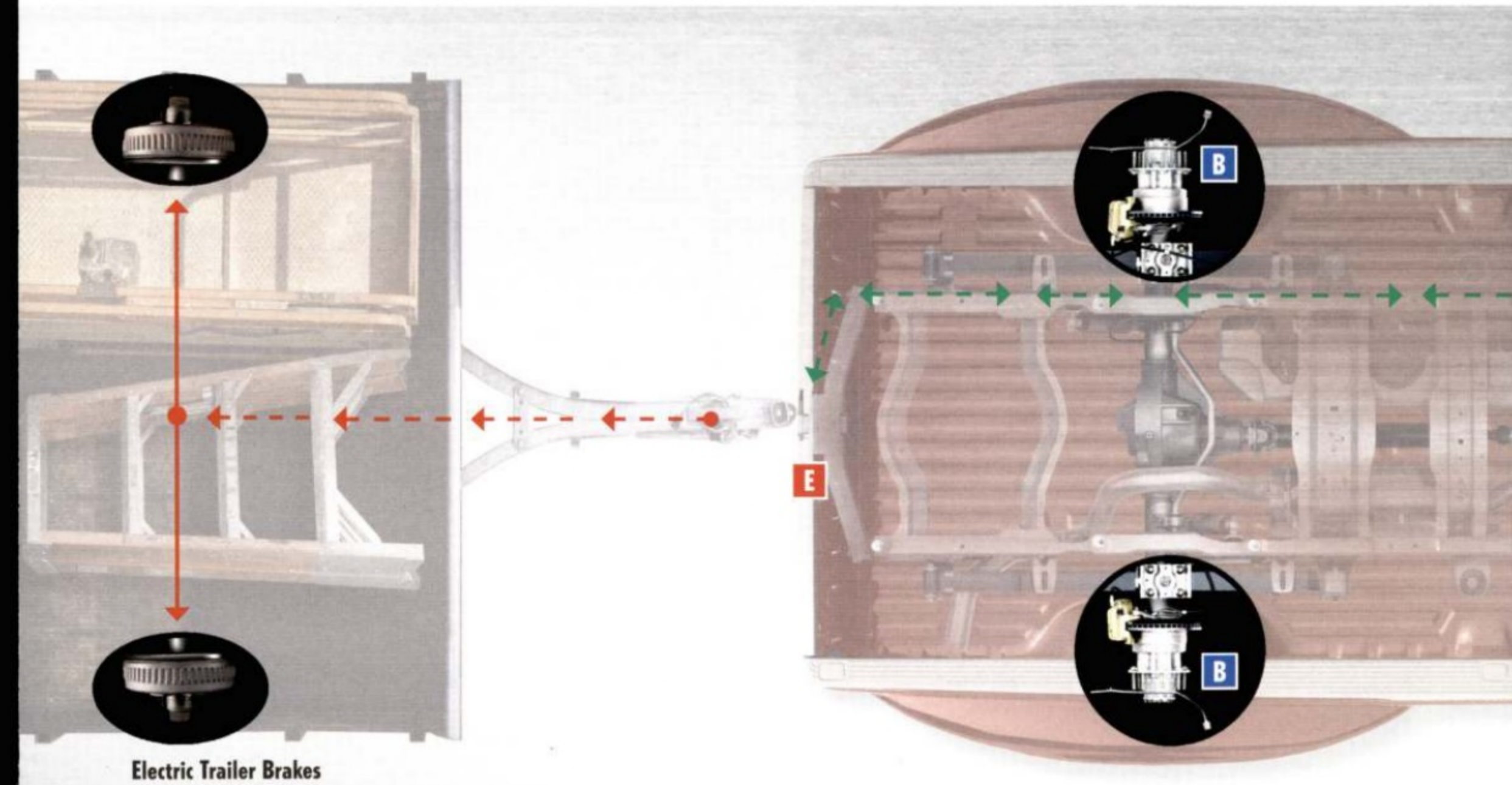

Electric Trailer Brakes

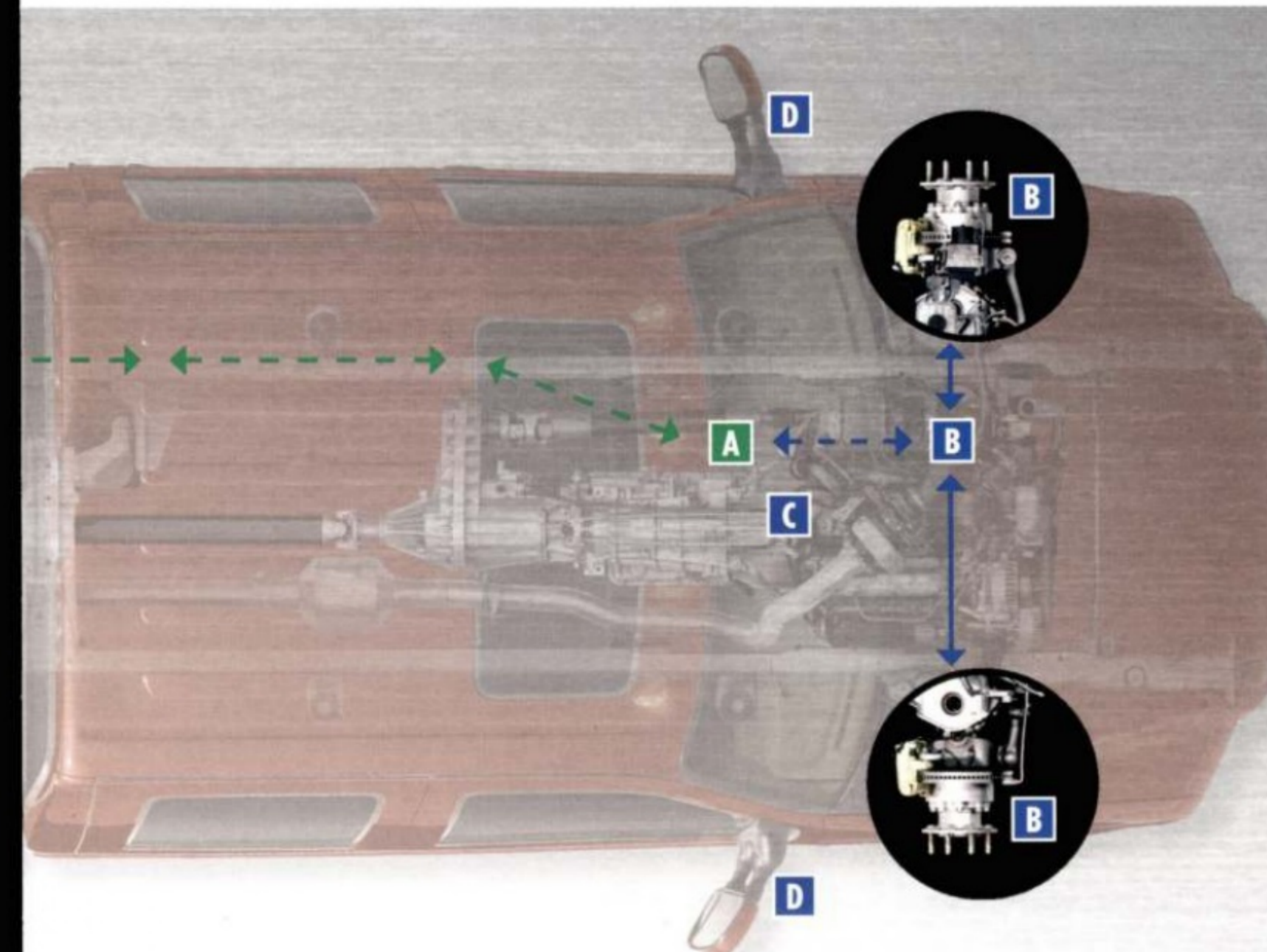

- A** Trailer Brake Controller
- Integrated computer control module
  - Manual control lever
  - Digital gain/output gauge
  - Connection status indicator
  - Disconnect alarm
  - Standard 7-pin connector

## Complete TowCommand System

- B** Brakes
- 4-Wheel Disc
  - Anti-lock Brake System
- C** TorqShift™ 5-Speed Automatic Transmission
- D** Telescoping Trailer Tow Mirrors

Towing Related Equipment:

- E** 15,000-lb.-Rated 2½" Hitch Receiver



### Convenience At Hand

**TowCommand Trailer Brake Controller** – Convenient placement of the fully integrated Trailer Brake Controller allows you to activate the trailer brakes manually while you adjust the gain setting to compensate for changes in trailer, loading or road conditions. The integrated design is clean and easy to reach.

**Upfitter Switches** – These 4 switches facilitate add-on system installations. Freestanding option, not included with Trailer Brake Controller.



### A Exclusive Towing Technology

**NEW TowCommand Integrated Trailer Brake Controller** – Developed, tested and factory installed by Ford, this optional controller is integrated with the Anti-lock Brake System. It synchronizes the vehicle and trailer brakes for seamless braking while towing even the heaviest loads. It has a built-in trailer disconnect alarm. And it comes warranted by Ford. The Ford design looks great and eliminates messy mounting and wiring of aftermarket installations. In short, it is the best-functioning controller available. And you can only get it on F-Series Super Duty. (See your dealer for limited warranty details.)

BEST INTERIOR  
**SPACE**



■ **Super Space**

Ford F-Series Super Duty is just as serious about leadership inside. It starts with best-in-class passenger room in every single cab style. The new instrument panel enhances the most spacious cabs, and trim options allow you to specify your truck to your requirements. From muddy work sites to business-class travel, F-Series Super Duty carries its crews in comfort and style.

# BEST TRUCKS

## ■ Because They Get More Done

Yeah, that's right. When you outperform the competition in every skill set – power, maximum payload, maximum towing, interior space, innovation, convenience, exclusive models – it stands to reason that you are the best truck. Need more proof? 27 years running and F-Series is still the sales leader. Case closed.



F-SERIES...

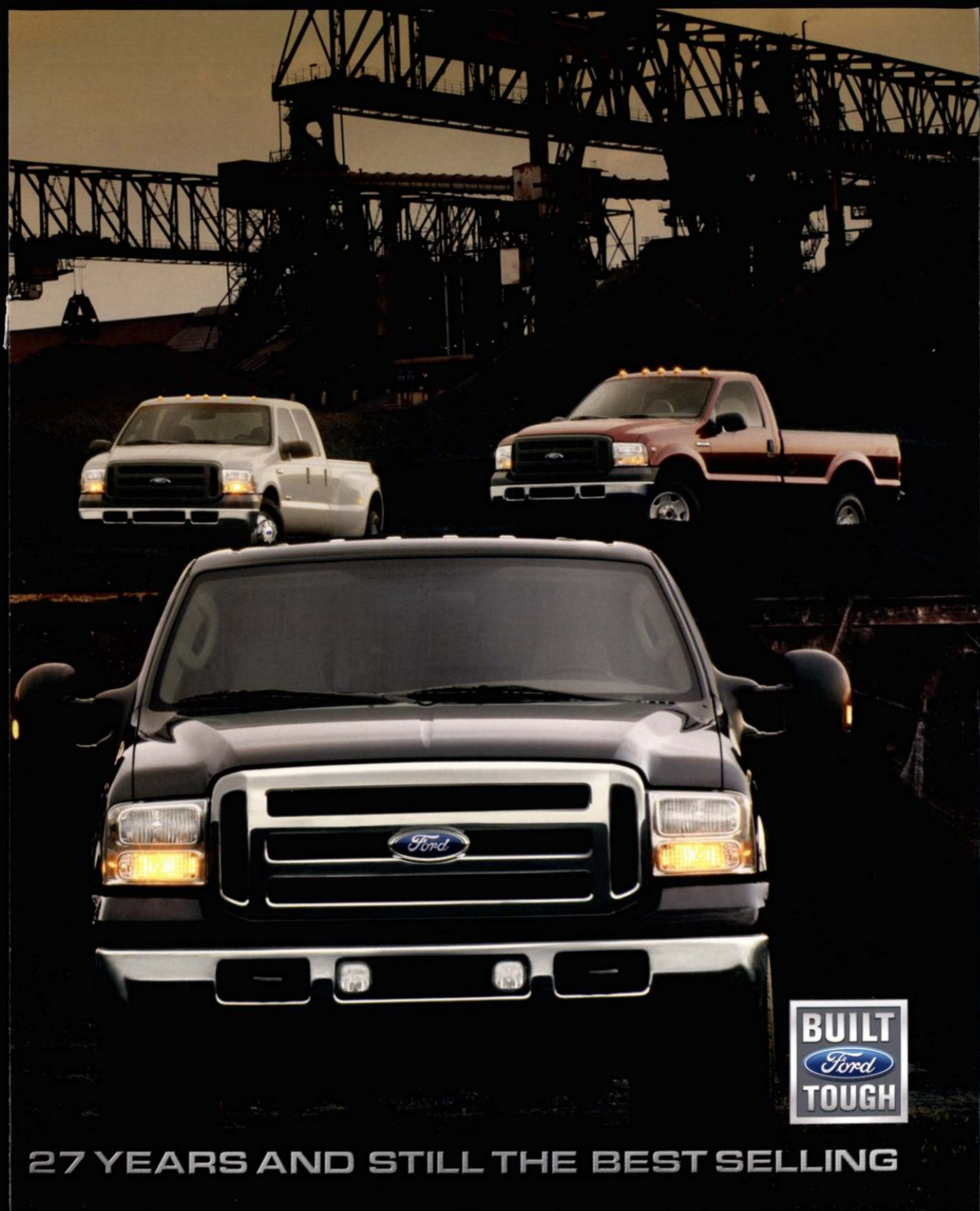

27 YEARS AND STILL THE BEST SELLING

# FULL CREDENTIALS

The Ford Super Duty XLT has all that a great truck needs, with the added finish work that sets it apart: chromed wheels, bumpers and grille appearance, air conditioning, power windows and locks, cloth seat trim, speed control/tilt steering, new available driver's glove compartment, and full carpeting and floor mats. There are lots of possibilities, too: Crew Cabs with a standard FlexFold™ rear seat, 4x4 Electronic Shift-On-the-Fly, TorqShift™ automatic transmission, optional two-tone paint, 18" forged polished-aluminum wheels, or the XLT Sport Package that adds a monochromatic look and unique interior features. Like to hear more? You can add an available AM/FM stereo with 6-disc in-dash CD changer. And that's just to name a few.



## ■ Dressed For Work

**NEW Uppfitter Switches** – These available switches provide a convenient power source for aftermarket power accessories such as winches, lifts, snowplows and auxiliary lighting. Their Ford design looks great, and they're available to work with your upfit.



## ■ Clear Off Your Dash

**Driver's Glove Compartment** – Why should passengers have all the space and storage? Now there's a glove compartment option for the driver, too. Super Duty's secondary glove compartment provides plenty of storage within reach of the driver. Available with automatic transmission and Electronic Shift-On-the-Fly only.



## ■ Sporting Black Leather

**Leather Sport Interior** – XLT Sport's available captain's chairs are offered in unique black leather trim to match the black rubber floor mats and a black leather-wrapped steering wheel.



# UNCOMPROMISING

You're demanding and you expect the best. You've earned it. That's why we build Lariat. No other truck combines toughness, capability and refinement like it. Its lengthy list of standard features satisfies an insatiable appetite – leather-trimmed, 40/20/40 split front seat, leather-wrapped tilt steering wheel with speed control, 17" premium forged polished-aluminum wheels, privacy glass, sliding rear window, premium AM/FM stereo/single-CD player, and remote keyless entry system. Still hungry for more? Add the available premium 18" forged-aluminum wheels, heated seats and Lariat Luxury Package which includes: duplicate steering wheel audio/climate controls, Electronic Automatic Temperature Control and more. Go ahead, expect more. You just might get it.

## Security Check

**Advanced Security Group** – Standard on Lariat, this package adds protection for you and your truck. It includes autolamp, autolock, illuminated entry, panic alarm, and remote keyless entry system with 2 key fobs and a driver's door entry keypad.



## Open Wide

**Power-Sliding Rear Window** – Even more air circulation is available on Lariat SuperCab and Crew Cab with the push of a button. Some days there's simply nothing better than a natural breeze.



## A Dash Of Refinement

**Lariat Luxury Package** – Available luxury package adds Electronic Automatic Temperature Control, an auto-dimming rearview mirror, a bronze-faced instrument cluster, an instrument pack with enhanced message center, duplicate steering wheel audio/climate controls, and refined woodgrain-style accents to Lariat models. (Some options shown are not in package.)





# THOROUGHbred

When only the top breed of truck will do, look no further than the F-Series Super Duty King Ranch Crew Cab. Its muscular exterior is defined by: 18" painted aluminum wheels (SRW) or 17" forged-aluminum wheels (DRW), diamond-plate illuminated cab steps, and telescoping trailer tow mirrors with power/heated glass, clearance lamps and turn signals. Inside, King Ranch is well-groomed, too. The heated front seats, quad captain's chairs, center console lids, grab handles and steering wheel are all trimmed in unique Castaño leather. And the required, optional woodgrain-appearance and bronze-style accents on the instrument panel and cluster gauges, duplicate steering wheel audio/climate controls, Electronic Automatic Temperature Control and available power-sliding rear window leave no doubt of King Ranch's pedigree. From front quarter to tailgate, it's the finest of its kind.

## ■ Fits Lots Of Shapes And Sizes

**FlexFold™ 60/40 Split Rear Seat** – Whatever your inner needs may be, the available Crew Cab rear FlexFold seating easily adjusts from passengers to a wide variety of storage capabilities. Fold the seats up or seatbacks down. Flat loadfloor or traditional cargo carrying, there are up to 9 different seat-position combinations to serve you.



## ■ Rugged Good Looks

**NEW 18" King Ranch Rims** – This painted aluminum wheel features a painted finish and the King Ranch brand on the center cap. Standard on single-rear-wheel models.



## ■ Big Sky

**Moonroof** – A little fresh air never hurt anyone. Super Duty's available power moonroof with sunshade opens things up and gives you fresh air to breathe.

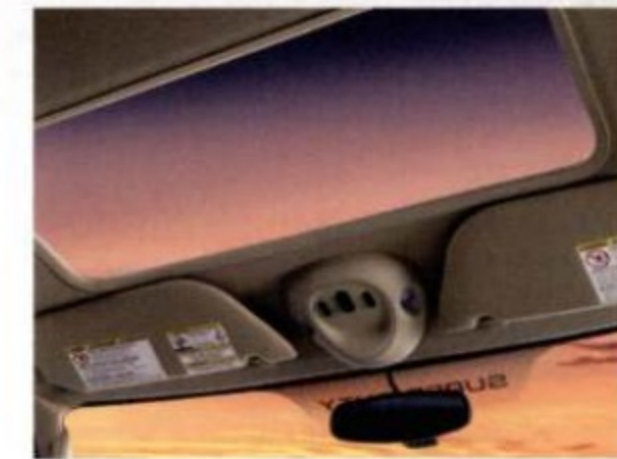

## ■ Come On Back

**Reverse Vehicle Aid Sensor** – This available system sounds an alarm to alert the driver to objects behind the vehicle. And when hitching a trailer, it's like having a friend to guide you.



## ■ Style With A Western Accent

**King Ranch Exterior** – 3 distinctive color schemes let you choose the King Ranch that reflects your taste. Arizona Beige accents recall western landscapes and wide-open spaces.



King Ranch Crew Cab 4x4 \_ shown with optional equipment

F-350 King Ranch DRW Crew Cab 4x4 \_  
Dark Copper/Arizona Beige Metallic Two-Tone

### Black Sheep

**Black Leather Trim** – Every family needs a black sheep. This is ours and we're very proud of it. A unique instrument panel, HARLEY-DAVIDSON logo on the seats, chromed seat controls, and a unique cluster separate this ride from the rest of the pack. Choose quad captain's chairs or go with an available rear bench seat. The customized serialization plate on the leather-wrapped console tells the rest of the world what you already know: yours is one of the select few in a limited-edition run.



### Chromed Gauges

**Unique Cluster** – The folks in Dearborn and Milwaukee attended to every last detail.



### Big And Solid

**20" Forged-Aluminum Wheels** – Hammered out by an 8000-ton press, at 20" in diameter these beauties are the largest forged-aluminum wheels offered in the class. Chromed lug nuts accent the Bar & Shield logo on center cap.



# HOTHEAD

Only one truck is big and tough enough to bear the "branding" of 2 legendary icons – the Ford Harley-Davidson™ F-Series Super Duty. Designers from Dearborn and Milwaukee deliver a bold American truck drenched with chrome, leather, and rich paint tattooed with available flames. A fierce billet grille insert intensifies the menacing front end. Inside, its two-tone full-grain leather trim with chrome and stainless steel accents complete America's Truck. Black and blue. No, we're not talking about leather and jeans. The deep Black paint with an orange pinstripe is standard. Feeling hot? Pick your favorite option: Black with red flames or True Blue with blue flames. No matter how you paint it, it's 100% Attitude. No adjustment required.



# SPECIFICATIONS

## STANDARD FEATURES

### Safety/Security

- 4-wheel power disc brakes with Anti-lock Brake System (ABS)
- Airbags\* – Driver and right-front passenger
- Alert chimes – Headlamps-on, key-in-ignition and door ajar
- Belt-Minder® safety belt reminder
- BlockerBeam® – Front bumper underride protection system
- Brake/shift interlock (with automatic transmission)
- Child-safety seat top tether anchors
- Fuel pump inertia shutoff switch
- Height-adjustable safety belts – Front (Regular Cab, XL SuperCab, Crew Cab)
- Locking tailgate
- Passenger airbag deactivation switch (Regular Cab, SuperCab)
- Safety belt energy-management retractors – Front outboard positions
- Side-impact door beams
- Spare tire/wheel lock

### Mechanical

- Manual 4-wheel-drive system with manual locking hubs (4x4 models only)
- 5.4L 3-valve SOHC Triton™ V8 engine
- 6-speed manual overdrive transmission
- 100,000-mile tune-up interval\*\* (gas engines)
- Battery saver
- Fail-safe engine cooling system (gas engines)
- Fuel tank – 29-gallon capacity with 6¾' box, 38-gallon capacity with 8' box
- Power steering
- Quick-release tailgate
- Spare tire/wheel/jack – Conventional with underframe carrier (crank-down type)
- Stabilizer bar – Front
- Stainless-steel exhaust system
- Steering damper
- Styleside bed – 6¾' and 8' SRW/DRW†

### Interior

- Assist and ride handles
- Coat hooks – 1 (Regular Cab), 2 in rear of cab (SuperCab and Crew Cab)
- Cupholders – 2 on instrument panel (2 in rear with SuperCab and XLT/Lariat Crew Cab)
- Dome light (front and rear with Crew Cab)
- Flip-open rear quarter windows (SuperCab)
- Power points – 2 on instrument panel (including lighter)
- Steering wheel – Black vinyl

### Exterior

- Bumpers – Front and rear step
- Cargo box lamp – Integrated with center high-mounted stop lamp
- Cargo box – Partitionable and stackable
- Cargo box rail and tailgate top moldings
- Cargo box stake pockets
- Cargo tie-down hooks – 4 in cargo box
- Solar-tinted glass
- Tow hooks – 2 in front
- Trailer tow – 7/4-pin connector and trailer brake wiring kit (in-cab, no controller)
- Windshield wipers – Interval

\*Always wear your safety belt and always deactivate the passenger airbag when using a rear-facing child-safety seat with Regular Cab and SuperCab models. Always wear your safety belt and always secure children in the rear seat in Crew Cab models.

\*\*Under normal driving conditions with routine fluid and filter changes.

†DRW available on F-350 models only.

## MODEL-SPECIFIC FEATURES & OPTIONS

	XL	XLT	Lariat
			<b>Safety/Security</b>
			Advanced Security Group – Includes autolamp, autolock, illuminated entry system, remote keyless entry system with 2 key fobs and driver's door entry keypad
			Reverse Vehicle Aid Sensor
			<b>Mechanical</b>
			5.4L 3-valve SOHC Triton V8 engine (not available on DRW Crew Cab)
			6.8L 3-valve SOHC Triton V10 engine (standard on DRW Crew Cab)
			6.0L OHV 32-valve Power Stroke® V8 Turbo Diesel engine
			TorqShift™ 5-speed automatic overdrive transmission
			Electronic Shift-On-the-Fly (ESOF) 4-wheel-drive system with auto/manual locking hubs (4x4 models only)
			17" argent-painted steel wheels – 5 (F-250)
			17" argent-painted steel wheels – 7 (F-350 DRW)
			17" chromed steel wheels – 4 (F-250)
			17" forged polished-aluminum wheels – 4 (F-250)
			17" forged polished-aluminum wheels – 4 (F-350 DRW)
			17" premium forged polished-aluminum wheels – 4 (F-250)
			18" premium forged polished-aluminum wheels – 4 (F-250/F-350 SRW)
			18" argent-painted steel wheels – 4 (F-350 SRW)
			18" chromed steel wheels – 4 (F-350 SRW)
			18" forged polished-aluminum wheels – 4 (F-350 SRW)
			LT245/75R17 all-season BSW tires – 5 (F-250)
			LT245/75R17 all-terrain BSW tires – 5 (F-250)
			LT265/70R17 all-season OWL tires – 4 (F-250)
			LT265/70R17 all-terrain BSW tires – 5 (F-250)
			LT265/70R17 all-terrain OWL tires – 4 (F-250)
			LT275/65R18 all-season BSW tires – 5 (F-250 4x2)
			LT275/65R18 all-season OWL tires – 4 (F-250 4x2)
			LT275/70R18 all-season BSW tires – 5 (F-250 4x4)
			LT275/70R18 all-terrain BSW tires – 5 (F-250 4x4)
			LT275/70R18 all-terrain OWL tires – 4 (F-250 4x4)
			LT275/65R18 all-season BSW tires – 4 (F-350 SRW 4x2)
			LT275/70R18 all-season BSW tires – 5 (F-350 SRW 4x4)
			LT275/65R18 all-season OWL tires – 4 (F-350 SRW 4x2)
			LT275/70R18 all-terrain BSW tires – 5 (F-350 SRW 4x4)
			LT275/70R18 all-terrain OWL tires – 4 (F-350 SRW 4x4)
			LT245/75R17 all-season BSW tires – 7 (F-350 DRW)
			LT245/75R17 all-terrain BSW tires – 7 (F-350 DRW)
			LT245/75R17 all-terrain OWL tires – 4 (F-350 DRW)
			Dual alternators – Total of 260 amps (diesel engine only)
			Higher-ratio rear axle
			Limited-slip rear axle
			Power TakeOff provision – Automatic transmission (included with man. trans.)
			Skid Plate Package – Transfer case and fuel tank (4x4 models only)
			TowCommand Integrated Trailer Brake Controller
			Trailer hitch receiver – 12.5K Built Ford Tough (SRW/F-350 DRW 5.4L)
			Trailer hitch receiver – 15K Built Ford Tough (F-350 DRW 6.8L/6.0L only)
			<b>Seating</b>
			Front reclining seat – HD vinyl (not available with Crew Cab)
			Front reclining seat – HD cloth/vinyl weave (standard with Crew Cab)
			Front reclining seat – HD cloth
			Front seat – 40/20/40 split with armrest, cupholders and storage (XL – HD vinyl, XLT – cloth, Lariat – leather-trimmed)
			Front bucket seats – HD vinyl
			Front bucket seats – HD cloth/vinyl weave
			Front bucket seats – HD cloth
			Front captain's chairs with console (XLT – cloth, Lariat – leather-trimmed)
			Rear fold-up bench seat (SuperCab)
			Rear bench with folding seatback (Crew Cab)
			Rear FlexFold™ 60/40 split fold-flat seat, bag hooks, dual integrated cupholders and tray, and 2 outboard head restraints (Crew Cab)
			Heated seats – Driver and front passenger

● Standard ● Select Availability ○ Optional — Not Available

†Available as part of the XL Décor Group.

	XL	XLT	Lariat
			<b>Seating (continued)</b>
			Lumbar support – Driver and front passenger
			Power 6-way driver's seat (and front-passenger seat on Crew Cab)
			<b>Interior</b>
			Accessory delay for power features
			Air conditioning
			AM/FM stereo/digital clock
			AM/FM stereo/single-CD player and digital clock
			AM/FM stereo/single-CD/cassette player and digital clock
			AM/FM stereo/6-disc in-dash CD changer and digital clock
			Radio delete (Regular Cab only)
			Driver's glove compartment (requires auto. trans. and ESOF)
			Floor covering – Black vinyl
			Floor covering – Color-coordinated carpet
			Floor mats – Color-coordinated carpet
			Floor mats – Black all-weather
			Overhead console – Includes sunglasses storage and garage door opener storage (SuperCab and Crew Cab only)
			Power-adjustable brake and accelerator pedals (with auto. trans. only)
			Power door locks
			Power windows with one-touch-down driver's-side feature
			Speed control/tilt steering wheel
			Steering wheel – Black leather-wrapped
			Storage tray – Behind seat (Regular Cab and Crew Cab)
			Uppfitter switches (4) – Located on instrument panel
			Visors with passenger mirror
			Visors with illuminated driver and front-passenger mirrors
			<b>Exterior</b>
			Bodyside moldings – Body-color (SRW only)
			Bumpers – Argent-painted
			Bumpers – Chrome††
			Cab steps – Black molded
			Cab steps – Chromed tubular
			Fog lamps
			Grille – Argent-painted
			Grille – Bright insert with chromed surround
			Headlamps – Sealed-beam halogen
			Headlamps – Dual-beam jewel-effect††
			Lamp – Underhood engine compartment††
			Mirrors – Manual sideview
			Mirrors – Power sideview
			Mirrors – Manual glass, manual-telescoping trailer tow with 2-way fold
			Mirrors – Power/heated glass with integrated clearance lamps, turn signals, manual-telescoping trailer tow with 2-way fold
			Moonroof – Power-slide (Crew Cab only; requires Advance Security Group on XLT)
			Privacy glass (rear doors and rear window)
			Roof clearance lamps (standard on DRW)
			Sliding rear window – Manual
			Sliding rear window – Power (SuperCab and Crew Cab only)
			Two-tone paint – Premium bodyside and lower accent
			Two-tone paint – Lower accent
			<b>Packages</b>
			<b>Camper Package</b> – Includes 2-up front springs (4x2 – 300-lb. upgrade) or 1-up front springs (4x4 – 400-lb. upgrade) above the spring computer-selected as a consequence of options chosen, not included if maximum springs have been computer-selected as standard equipment; rear stabilizer bar (SRW); slide-in-camper certification; auxiliary rear springs where not standard
			<b>FX4 Off-Road Package</b> – Includes transfer case and fuel tank skid plates; specifically tuned front and rear shocks; FX4 Off-Road decal
			<b>Harley-Davidson™ F-Series Super Duty</b> (late availability) – Includes unique tape stripe with "Harley-Davidson" script; body-color grille and bumpers; "Harley-Davidson F-Series Super Duty" badges on front fenders and tailgate; body-color wheel-lip moldings and door handles; chromed tubular step bars with HARLEY-DAVIDSON Bar & Shield logo insert; unique chromed exhaust tip;

	XL	XLT	Lariat
			<b>Packages (continued)</b>
			unique engine decal; Ford Harley-Davidson vanity license plate; rubber bed mat with HARLEY-DAVIDSON Bar & Shield logo; manual-telescoping trailer tow mirrors with power/heated glass and integrated clearance lamps and turn signals; chromed front tow hooks and chromed tie-downs; 20" brushed forged-aluminum wheels with chromed lug nuts and the Bar & Shield logo on center caps; LT275/65R20E all-terrain BSW tires; unique windshield with Bar & Shield logo dot pattern and Alliance logo; Electronic Automatic Temperature Control (EATC); auto-dimming rearview mirror; ebony leather-wrapped steering wheel with duplicate audio/climate controls; unique power-adjustable performance pedals; black molded-rubber floor mats with "Harley-Davidson" script; instrumentation pack with enhanced message center; "spun-metal face" cluster finish panel; unique owner's guide with truck badge logo-embossed leather portfolio; laser-engraved serialization plate; unique key set with Ford/Harley-Davidson logo on key ends; black leather-trimmed quad captain's chairs with embossed HARLEY-DAVIDSON Bar & Shield logo; front and rear center console lids trimmed in leather (Crew Cab) (Optional FlexFold 60/40 split rear bench in unique leather trim with embossed HARLEY-DAVIDSON Bar & Shield logo)
			<b>Heavy-Service Suspension Package</b> – Includes 1-up front spring (4x2 – 150 lb., 4x4 – 400 lb. upgrade above the spring computer-selected as a consequence of options chosen; not included if maximum springs have been computer-selected as standard equipment); auxiliary rear springs where not standard
			<b>King Ranch</b> – Includes Arizona Beige lower-accent two-tone paint; unique color-keyed exterior door handles; Arizona Beige exterior accents; unique King Ranch fender and tailgate badges; lighted cab steps with diamond-plate inserts (Arizona Beige); body-color manual-telescoping trailer tow mirrors with power/heated glass and integrated clearance lamps and turn signals; unique 18" painted aluminum wheels (SRW); 17" forged-aluminum wheels and wheel-center cap with King Ranch brand (DRW); front and rear floor mats with King Ranch brand; heated seats (driver and front-passenger); King Ranch brand on instrument panel; front and rear consoles with Castaño leather-covered lid/armrests; full-grained leather-wrapped grab handles and steering wheel with duplicate audio/climate controls; Castaño leather-trimmed quad captain's chairs
			<b>Lariat Luxury Package</b> – Includes Electronic Automatic Temperature Control (EATC); auto-dimming rearview mirror; bronze-faced instrumentation cluster; instrumentation pack with enhanced message center; duplicate steering wheel audio/climate controls; woodgrain instrument panel insert
			<b>Snow Plow Prep Package</b> – Front springs/GAWR upgrade (5200 or 5600 lbs. with gas engine; 6000 lbs. with diesel engine) auxiliary rear springs where not standard; 140-amp. alternator with diesel engine (4x4 only)
			<b>Stabilizer Package</b> – Includes heavy-service front springs and rear stabilizer bar (available on SRW; n/a with Heavy-Service Suspension Package)
			<b>TowCommand Package</b> (requires TorqShift™ automatic transmission) – Includes TowCommand Integrated Trailer Brake Controller, manual-telescoping trailer tow mirrors with manual glass (XL) or manual-telescoping trailer tow mirrors with power heated glass and integrated clearance lamps/turn signals (XLT and Lariat)
			<b>XL Décor Group</b> – Includes chrome bumpers; dual-beam jewel-effect headlamps; bright chromed hub covers and center ornaments; underhood engine-compartment lamp
			<b>XLT Sport Package</b> – Includes monochromatic exterior colors; body-color grille and bumpers; body-color door handles; bodyside moldings; privacy glass; sliding rear window; fog lamps; chrome tubular step bars; chrome exhaust tip; unique 40/20/40 split two-tone cloth seats (ebony/charcoal); ebony carpet; unique front and rear block all-weather throw-in rubber floor mats; unique black leather-wrapped steering wheel; unique ebony interior accents; unique door-trim panels with ebony armrest and power-switch bezels and platinum upper appliqué (SuperCab rear door-trim panels include ebony armrest/ashtray only); unique ebony B- and C-pillar moldings (Crew Cab only)

Comparisons based on 2004 competitive models. Publicly available information and Ford certification data at time of printing. Some features discussed may be optional. Vehicles shown may contain optional equipment. Features shown may be offered only in combination with other options or subject to additional ordering requirements or limitations. Following publication of the catalog, certain changes in standard equipment, options and the like, or product delays may have occurred which would not be included in these pages. Your Ford Dealer is the best source for up-to-date information. Ford Division reserves the right to change product specifications at any time without incurring obligations.

## F-250/F-350 MAXIMUM PAYLOAD/TOWING



REGULAR CAB: MAX. PAYLOAD  
F-350 SRW – Max. 4400 lbs.  
F-350 DRW – Max. 5800 lbs.



SUPERCAB: MAX. PAYLOAD  
F-350 SRW – Max. 4300 lbs.  
F-350 DRW – Max. 5800 lbs.



CREW CAB: MAX. PAYLOAD  
F-350 SRW – Max. 4300 lbs.  
F-350 DRW – Max. 5800 lbs.



REGULAR CAB: MAX. CONVENTIONAL/MAX. 5TH-WHEEL TOWING  
F-250/F-350 SRW – 12,500/17,000 lbs.\*  
F-350 DRW – 15,000/16,700 lbs.



SUPERCAB: MAX. CONVENTIONAL/MAX. 5TH-WHEEL TOWING  
F-250/F-350 SRW – 12,500/16,600 lbs.  
F-350 DRW – 15,000/16,300 lbs.



CREW CAB: MAX. CONVENTIONAL/MAX. 5TH-WHEEL TOWING  
F-250/F-350 SRW – 12,500/16,400 lbs.  
F-350 DRW – 15,000/16,100 lbs.

\*F-350 SRW only.

### MORE GVWR RATINGS

F-Series Super Duty models now maintain near-maximum payload capacity even when a larger cab or engine is selected.

### MAXIMUM PAYLOAD WEIGHT RATING (LBS.) – Model/ Wheelbase

Series	GVWR (lbs.)	Regular Cab		SuperCab		Crew Cab	
		Pickup 137.0"	Pickup 141.8"	Pickup 158.0"	Pickup 156.2"	Pickup 172.4"	Pickup
F-250 4x2	8800	3000 <sup>1</sup>	—	—	—	—	—
	9000	3100 <sup>2</sup>	3100 <sup>1</sup>	—	—	—	—
	9200	—	3100 <sup>2</sup>	3100 <sup>1</sup>	3000 <sup>1</sup>	—	—
	9400	3000 <sup>3</sup>	—	3200 <sup>2</sup>	3100 <sup>2</sup>	3100 <sup>1</sup>	—
	9600	—	3000 <sup>3</sup>	—	3000 <sup>3</sup>	3200 <sup>2</sup>	—
	9800	—	—	3100 <sup>3</sup>	—	—	—
F-250 4x4	10,000	—	—	—	—	3000 <sup>3</sup>	—
	9000	2800 <sup>1</sup>	—	—	—	—	—
	9200	2800 <sup>2</sup>	2800 <sup>1</sup>	—	—	—	—
	9400	—	2900 <sup>2</sup>	2800 <sup>1</sup>	2700 <sup>1</sup>	—	—
	9600	2700 <sup>3</sup>	—	2900 <sup>2</sup>	2800 <sup>2</sup>	2800 <sup>1</sup>	—
	9800	—	2800 <sup>3</sup>	—	—	2900 <sup>2</sup>	—
F-350 4x2 SRW	10,000	—	—	2800 <sup>3</sup>	2700 <sup>3</sup>	2600 <sup>3</sup>	—
	10,100	4300 <sup>1</sup>	—	—	—	—	—
	10,200	—	4200 <sup>1</sup>	—	—	—	—
	10,300	4400 <sup>2</sup>	—	—	—	—	—
	10,400	—	4300 <sup>2</sup>	4300 <sup>1</sup>	4200 <sup>1</sup>	—	—
	10,600	—	—	4300 <sup>2</sup>	4300 <sup>2</sup>	4200 <sup>1</sup>	—
F-350 4x4 SRW	10,700	4200 <sup>3</sup>	—	—	—	—	—
	10,800	—	4200 <sup>3</sup>	—	—	4300 <sup>2</sup>	—
	11,000	—	—	4200 <sup>3</sup>	4100 <sup>3</sup>	—	—
	11,200	—	—	—	—	4200 <sup>3</sup>	—
	11,500	—	—	—	—	—	—
	11,800	—	—	—	—	—	—
F-350 4x2 DRW	10,500	4200 <sup>1</sup>	—	—	—	—	—
	10,600	—	4100 <sup>1</sup>	—	—	—	—
	10,700	4300 <sup>2</sup>	—	—	—	—	—
	10,800	—	4200 <sup>2</sup>	4200 <sup>1</sup>	4100 <sup>1</sup>	—	—
	11,000	—	—	4300 <sup>2</sup>	4200 <sup>2</sup>	4200 <sup>1</sup>	—
	11,100	4200 <sup>3</sup>	—	—	—	—	—
F-350 4x4 DRW	11,200	—	4100 <sup>3</sup>	—	—	4200 <sup>2</sup>	—
	11,400	—	—	4100 <sup>3</sup>	4100 <sup>3</sup>	—	—
	11,500	—	—	—	—	4000 <sup>3</sup>	—
	11,800	5700 <sup>1</sup>	—	—	—	—	—
	12,000	5800 <sup>2</sup>	—	—	—	—	—
	12,200	—	—	5800 <sup>1</sup>	—	—	—
F-350 4x4 DRW	12,400	5700 <sup>3</sup>	—	5800 <sup>2</sup>	5800 <sup>2</sup>	—	—
	12,600	—	—	—	—	5800 <sup>2</sup>	—
	12,800	—	—	5700 <sup>3</sup>	5700 <sup>3</sup>	—	—
	13,000	—	—	—	—	5700 <sup>3</sup>	—
	12,000	5400 <sup>1</sup>	—	—	—	—	—
	12,200	5500 <sup>2</sup>	—	—	—	—	—
F-350 4x4 DRW	12,400	—	—	5500 <sup>1</sup>	—	—	—
	12,600	5400 <sup>3</sup>	—	5600 <sup>2</sup>	5500 <sup>2</sup>	5300 <sup>2</sup>	—
	12,800	—	—	5500 <sup>3</sup>	—	—	—
	13,000	—	—	—	5400 <sup>3</sup>	5200 <sup>3</sup>	—

<sup>1</sup>5.4L/6-speed manual. <sup>2</sup>6.8L/6-speed manual. <sup>3</sup>6.0L/6-speed manual.

### CONVENTIONAL TOWING Maximum Loaded Trailer Weight (lbs.)

Automatic Transmission	Axle Ratio	GCWR (lbs.)	Regular Cab				SuperCab				Crew Cab			
			F-250/F-350 SRW 4x2	F-350 DRW 4x2	F-250/F-350 SRW 4x4	F-350 DRW 4x4	F-250/F-350 SRW 4x2	F-350 DRW 4x2	F-250/F-350 SRW 4x4	F-350 DRW 4x4	F-250/F-350 SRW 4x2	F-350 DRW 4x2	F-250/F-350 SRW 4x4	F-350 DRW 4x4
5.4L 3-Valve SOHC V8	3.73	16,000	10,000	—	9600	—	9700	—	9200	—	9500	—	9000	—
	4.10	18,000	12,000	—	11,600	—	11,700	—	11,200	—	11,500	—	11,000	—
6.8L 3-Valve SOHC V10	4.10	18,500	—	12,300	—	11,800	—	11,900	—	11,400	—	—	—	—
		21,000	12,500	—	12,500	—	12,500	—	12,500	—	12,500	—	12,500	—
	4.30	21,500	—	15,000	—	14,700	—	14,800	—	14,400	—	14,600	—	14,100
		22,500/23,000 <sup>1</sup>	12,500	—	12,500	—	12,500	—	12,500	—	12,500	—	12,500	—
6.0L Turbo Diesel V8	3.73	23,000	12,500	—	12,500	—	12,500	—	12,500	—	12,500	—	12,500	—
		23,500	—	15,000	—	15,000	—	15,000	—	15,000	—	15,000	—	
	4.10	23,500	—	15,000	—	15,000	—	15,000	—	15,000	—	15,000	—	

### Manual Transmission

5.4L 3-Valve SOHC V8	3.73	15,000	9000	—	8600	—	8700	—	8200	—	8500	—	8000	—
	4.10	17,000	11,000	—	10,600	—	10,700	—	10,200	—	10,500	—	10,000	—
6.8L 3-Valve SOHC V10	4.10	17,500	—	11,300	—	10,800	—	10,900	—	10,500	—	—	—	—
		20,000	12,500	—	12,500	—	12,500	—	12,500	—	12,500	—	12,500	—
	4.30	20,500	—	14,100	—	13,700	—	13,800	—	13,300	—	13,600	—	13,100
		22,000	12,500	—	12,500	—	12,500	—	12,500	—	12,500	—	12,500	—
6.0L Turbo Diesel V8	3.73	22,500	—	15,000	—	15,000	—	15,000	—	15,000	—	15,000	—	15,000
		23,000	12,500	—	12,500	—	12,500	—	12,500	—	12,500	—	12,500	—
	4.10	23,500	—	15,000	—	15,000	—	15,000	—	15,000	—	15,000	—	

### 5TH-WHEEL TOWING Maximum Loaded Trailer Weight (lbs.)

Automatic Transmission	Axle Ratio	GCWR (lbs.)	Regular Cab				SuperCab				Crew Cab			
			F-250/F-350 SRW 4x2	F-350 DRW 4x2	F-250/F-350 SRW 4x4	F-350 DRW 4x4	F-250/F-350 SRW 4x2	F-350 DRW 4x2	F-250/F-350 SRW 4x4	F-350 DRW 4x4	F-250/F-350 SRW 4x2	F-350 DRW 4x2	F-250/F-350 SRW 4x4	F-350 DRW 4x4
5.4L 3-Valve SOHC V8	3.73	16,000	10,000	—	9600	—	9700	—	9200	—	9500	—	9000	—
	4.10	18,000	12,000	—	11,600	—	11,700	—	11,200	—	11,500	—	11,000	—
6.8L 3-Valve SOHC V10	4.10	18,500	—	12,300	—	11,800	—	11,900	—	11,400	—	—	—	—
		21,000	15,000	—	14,500	—	14,600	—	14,200	—	14,400	—	13,900	—
	4.30	21,500	—	15,200	—	14,700	—	14,800	—	14,400	—	14,600	—	14,100
		22,500/23,000 <sup>1</sup>	16,500/17,000 <sup>1</sup>	—	16,000/16,500 <sup>1</sup>	—	16,100/16,600 <sup>1</sup>	—	15,700/16,200 <sup>1</sup>	—	15,900/16,400 <sup>1</sup>	—	15,400/15,900 <sup>1</sup>	—
6.0L Turbo Diesel V8	3.73	23,000	16,500	—	15,800	—	16,100	—	15,600	—	15,900	—	15,400	—
		23,500	—	16,700	—	16,200	—	16,300	—	15,900	—	16,100	—	15,600
	4.10	23,500	—	16,700	—	16,200	—	16,300	—	15,900	—	16,100	—	15,600

### Manual Transmission

5.4L 3-Valve SOHC V8	3.73	15,000	9000	—	8600	—	8700	—	8200	—	8500	—	8000	—
	4.10	17,000	11,000	—	10,600	—	10,700	—	10,200	—	10,500	—	10,000	—
6.8L 3-Valve SOHC V10	4.10	17,500	—	11,300	—	10,800	—	10,900	—	10,500	—	—	—	—
		20,000	13,900	—	13,500	—	13,600	—	13,100	—	13,400	—	12,900	—
	4.30	20,500	—	14,100	—	13,700	—	13,800	—	13,300	—	13,600	—	13,100
		22,000	15,900	—	15,500	—	15,600	—	15,100	—	15,400	—	14,900	—
6.0L Turbo Diesel V8	3.73	22,500	—	16,100	—	15,700	—	15,800	—	15,300	—	15,600	—	15,100
		23,000	16,400	—	15,900	—	16,100	—	15,600	—	15,800	—	15,400	—
	4.10	23,500	—	16,600	—	16,200	—	16,300	—	15,800	—	16,100	—	15,600

Maximum capabilities shown are for properly equipped vehicles with required equipment and a 150-lb. driver. Weight of additional options, equipment, passengers and cargo must be deducted from this weight. For additional information, see your Ford Dealer.

**Conventional Towing Notes:** This information also applies to models with Pickup Box Delete option (66D). Trailer tongue load weight should be 10-15% of total loaded trailer weight. Make sure that the vehicle payload (reduced by option weight) will accommodate trailer tongue load weight and the weight of passengers and cargo added to the towing vehicle. The addition of trailer tongue load weight, and the weight of passengers and cargo cannot cause vehicle weights to exceed the rear GAWR (Gross Axle Weight Rating) or GVWR (Gross Vehicle Weight Rating). These ratings can be found on the vehicle Safety Compliance Certification Label. For F-250/F-350 SRW models, F-350 trailer weights are shown; F-250 trailer weights are within 100 pounds. Check with your sales consultant.

**5th-Wheel Towing Notes:** This information also applies to models with Pickup Box Delete option (66D). Trailer kingpin weight should be 15-25% of total loaded trailer weight. Make sure that the vehicle payload (reduced by option weight) will accommodate trailer kingpin weight and the weight of passengers and cargo added to the towing vehicle. The addition of trailer kingpin weight, and the weight of passengers and cargo cannot cause vehicle weights to exceed the rear GAWR (Gross Axle Weight Rating) or GVWR (Gross Vehicle Weight Rating). These ratings can be found on the vehicle Safety Compliance Certification Label. For F-250/F-350 SRW models, F-350 trailer weights are shown; F-250 trailer weights are within 100 pounds. Check with your sales consultant.

**Conventional and 5th-Wheel Towing Footnote:** <sup>1</sup>Available with F-350 SRW models only.

## DIMENSIONS

	Regular Cab 4x2/4x4	SuperCab SWB 4x2/4x4	SuperCab LWB 4x2/4x4	Crew Cab SWB 4x2/4x4	Crew Cab LWB 4x2/4x4
<b>Exterior</b>					
A. Height – F-250 SRW	76.5"/79.1"	77.0"/79.5"	76.8"/79.4"	77.5"/80.0"	77.3"/79.9"
A. Height – F-350 SRW	76.8"/80.8"	77.3"/81.4"	77.1"/81.2"	77.8"/81.8"	77.6"/81.7"
A. Height – F-350 DRW	76.7"/79.6"	—	77.0"/79.6"	77.6"/80.1"	77.4"/80.0"
B. Overall width – SRW (excl. mirrors)	79.9"	79.9"	79.9"	79.9"	79.9"
B. Overall width – DRW (at rear wheelhousing)	95.5"	—	95.5"	95.5"	95.5"
C. Ground clearance (rear axle) F-250	8.5"	8.5"	8.5"	8.5"	8.5"
C. Ground clearance (rear axle) F-350 SRW	8.8"/9.3"	8.8"/9.3"	8.8"/9.3"	8.8"/9.3"	8.8"/9.3"
C. Ground clearance (rear axle) F-350 DRW	8.7"	—	8.7"	8.7"	8.7"
D. Loadfloor height F-250	33.9"/35.1"	33.9"/35.1"	33.7"/35.0"	33.8"/35.0"	33.6"/34.9"
D. Loadfloor height F-350 SRW	34.2"/38.6"	34.2"/38.5"	34.1"/38.3"	34.1"/38.4"	33.9"/38.2"
D. Loadfloor height F-350 DRW	34.3"/35.4"	—	34.1"/35.3"	34.1"/35.3"	34.0"/35.3"
E. Cargo box height with molding	20.0"	20.0"	20.0"	20.0"	20.0"
F. Overall length	226.4"	231.2"	247.4"	245.6"	261.8"
G. Overhang – rear	52.2"	52.2"	52.2"	52.2"	52.2"
H. Wheelbase	137.0"	141.8"	158.0"	156.2"	172.4"
I. Overhang – front	37.2"	37.2"	37.2"	37.2"	37.2"
J. Angle of departure F-250	10.7°/12.8°	10.7°/12.8°	10.6°/12.8°	10.6°/12.8°	10.7°/12.8°
J. Angle of departure F-350 SRW	10.7°/14.9°	10.7°/14.9°	10.6°/14.9°	10.6°/15.0°	10.7°/15.0°
J. Angle of departure F-350 DRW	10.7°/12.9°	—	10.7°/12.9°	10.7°/12.9°	10.7°/12.9°
K. Ramp breakover angle F-250	13.3°/17.8°	12.9°/17.1°	11.6°/15.5°	11.7°/15.6°	10.8°/19.3°
K. Ramp breakover angle F-350 SRW	13.3°/19.3°	12.9°/18.7°	11.6°/16.8°	11.7°/17.0°	10.8°/15.6°
K. Ramp breakover angle F-350 DRW	13.4°/17.8°	—	11.6°/15.5°	11.7°/15.7°	10.8°/14.5°
L. Angle of approach F-250	19.2°/25.7°	19.2°/25.7°	19.2°/25.7°	19.2°/25.7°	19.2°/25.7°
L. Angle of approach F-350 SRW	19.2°/25.7°	19.2°/25.7°	19.2°/25.7°	19.2°/25.7°	19.2°/25.7°
L. Angle of approach F-350 DRW	19.2°/25.6°	—	19.2°/25.6°	19.2°/25.6°	19.2°/25.6°

	Regular Cab 4x2/4x4	SuperCab SWB 4x2/4x4	SuperCab LWB 4x2/4x4	Crew Cab SWB 4x2/4x4	Crew Cab LWB 4x2/4x4
<b>Interior</b>					
<b>Front</b>					
Head room	41.1"	41.4"	41.4"	41.3"	41.3"
Shoulder room	68.0"	68.0"	68.0"	68.0"	68.0"
Hip room	67.4"	67.4"	67.4"	67.4"	67.4"
Leg room	41.0"	41.0"	41.0"	40.7"	40.7"
<b>Rear</b>					
Head room	—	38.2"	38.2"	40.8"	40.8"
Shoulder room	—	68.0"	68.0"	68.0"	68.0"
Hip room	—	67.3"	67.3"	67.3"	67.3"
Leg room	—	32.2"	32.2"	41.7"	41.7"

	Regular Cab 4x2/4x4	SuperCab SWB 4x2/4x4	SuperCab LWB 4x2/4x4	Crew Cab SWB 4x2/4x4	Crew Cab LWB 4x2/4x4
<b>Cargo Box</b>					
Volume (cu. ft.)	77.8	64.8	77.8	64.8	77.8
M. Length at floor	98.6"	82.4"	98.6"	82.4"	98.6"
N. Width at top of box (rear opening)	63.5"	63.5"	63.5"	63.5"	63.5"
O. Width at wheelhouse	50.9"	50.9"	50.9"	50.9"	50.9"

SRW = single rear wheel DRW = dual rear wheel SWB = short wheelbase (6'1/2' cargo box) LWB = long wheelbase (8' cargo box)

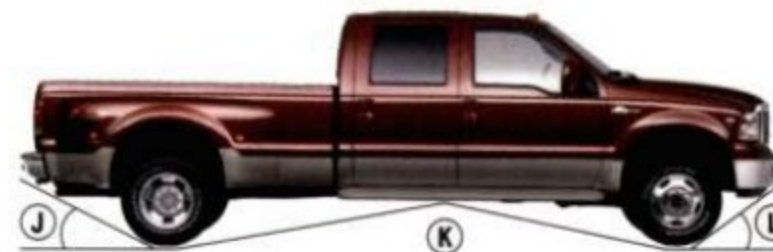
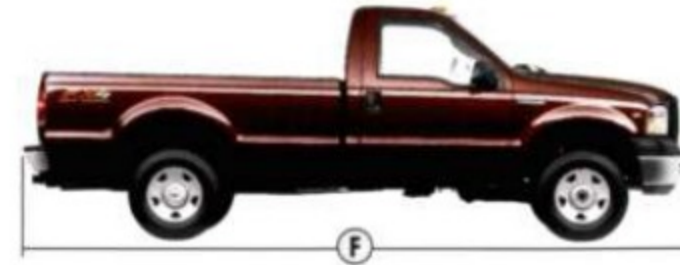

## F-SERIES SUPER DUTY

### Front Suspension

Type	Twin-I-Beam (4x2); solid Twin-Coil Monobeam axle (4x4)
Axle (rating @ ground)	4850 lbs. (4x2); 6000 lbs. (4x4)
Springs	Coil
Shock absorbers	1 <sup>3</sup> / <sub>8</sub> " gas type
Stabilizer bar	Standard

### Rear Suspension

Type	Solid axle
Axle (rating @ ground)	6200 lbs. (F-250); 7280 lbs. (F-350 SRW); 9000 lbs. (F-350 DRW)
Springs	Leaf
Shock absorbers	1 <sup>3</sup> / <sub>8</sub> " gas type
Stabilizer bar	Standard on DRW pickup; optional in package on SRW pickup

### Steering

Assist	Power
Overall ratio	20.16:1 (4x2); 20.38:1 (4x4)

### Brakes

Type	4-wheel disc ABS (standard)
Front	13.66" rotor diameter
Rear	13.39" rotor diameter

### Wheels

Type	Steel (standard); chromed steel or aluminum (optional)
Size	17" (standard F-250/F-350 DRW); 18" (standard F-350 SRW, optional F-250)
Number of studs	8
Bolt-circle diameter	6.7" (170 mm) SRW; 7.87" (200 mm) DRW

### Powertrains

Engine	4x4 Transfer Case	6-Speed Manual	5-Speed Automatic
5.4L 3-Valve Triton™ SEFI V8	2-speed manual	●	○
6.8L 3-Valve Triton SEFI V10	2-speed manual	○	○
6.0L Power Stroke® V8 Turbo Diesel	2-speed manual	○	○

● Standard ○ Optional

## ENGINES

	5.4L 3-Valve Triton V8 SOHC	6.8L 3-Valve Triton V10 SOHC	6.0L Power Stroke V8 Turbo Diesel OHV (32-Valve)
Type	Sequential Electronic	Sequential Electronic	Direct Electro-Hydraulic w/ Generation 2 fuel injection
Fuel injection	Sequential Electronic	Sequential Electronic	Direct Electro-Hydraulic w/ Generation 2 fuel injection
Engine control system	Electronic	Electronic	Electronic
Induction system	Specially tuned	Specially tuned	Electronic Variable Response Turbocharger (EVRT™), intercooler
Battery	12-volt; 650-cca/72-amp	12-volt; 650-cca/72-amp	Dual 12-volt; 750-cca/78-amp
Alternator	130-amp	130-amp	130-amp (Dual combined 260-amp opt.)
Cooling system	Pressurized series flow	Pressurized series flow	Pressurized series flow
Cylinders	8	10	8
Cylinder-head material	Aluminum	Aluminum	Cast iron
Block material	Cast iron	Cast iron	Cast iron
Valve operation	Hydraulic roller	Hydraulic roller	Push rod/rocker arms
Camshaft drive	Variable cam timing	Silent chain	Gear
Bore	3.55"	3.55"	3.74"
Stroke	4.16"	4.16"	4.13"
Compression ratio	9.8:1	9.2:1	18.0:1
Horsepower (hp @ rpm)	300 @ 5000	362 @ 4750	325 @ 3300
Torque (lb.-ft. @ rpm)	365 @ 3750	457 @ 3250	570 @ 2000
Recommended fuel	Unleaded	Unleaded	Diesel

## WHEELS



17" Argent-Painted Steel Wheel



18" Argent-Painted Steel Wheel



17" Chromed Steel Wheel



18" Chromed Steel Wheel



17" Forged Polished-Aluminum Wheel



18" Forged Polished-Aluminum Wheel



17" Premium Forged Polished-Aluminum Wheel



18" Premium Forged Polished-Aluminum Wheel



18" Painted Aluminum Wheel



20" Polished Forged-Aluminum Wheel



17" Argent-Painted Steel Wheel (DRW)



17" Polished Forged-Aluminum Wheel (DRW)

## INTERIOR COLORS

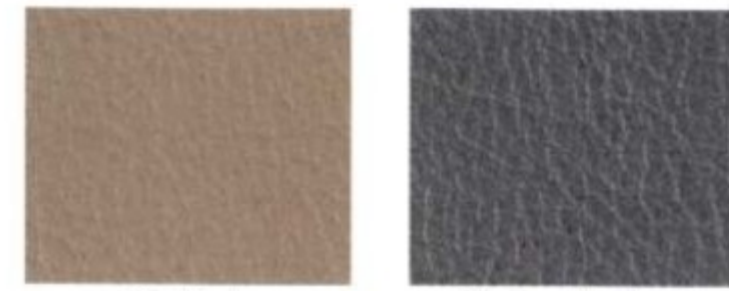

Tan Vinyl

Medium Flint Vinyl



Tan Cloth

Medium Flint Cloth



Tan Cloth/Vinyl Weave

Medium Flint Cloth/Vinyl Weave



Tan Premium Cloth

Medium Flint Premium Cloth

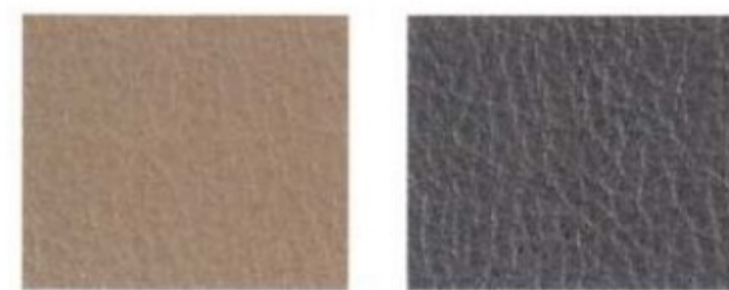

Tan Leather

Medium Flint Leather



Dark Flint Two-Tone Cloth

Black Leather

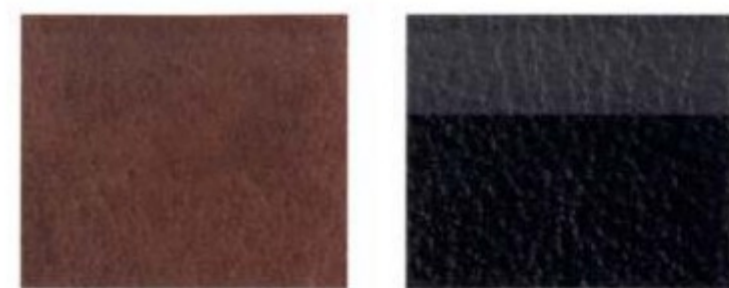

Castaño Leather

Harley-Davidson

Tan	
<b>Medium Flint</b>	
<b>XL/XLT</b>	
●	Oxford White
●	Arizona Beige Metallic
● ●	Red
● ●	Dark Toreador Red Metallic
● ●	Dark Green Satin Metallic
● ●	Medium Wedgewood Blue Metallic
● ●	True Blue Metallic
●	Silver Metallic
●	Dark Shadow Grey Metallic
●	Dark Stone Metallic*
● ●	Black
<b>XLT Premium Two-Tone</b>	
●	Oxford White/Arizona Beige Metallic
●	Oxford White/Silver Metallic
●	Dark Toreador Red Metallic/Arizona Beige Metallic
●	Dark Toreador Red Metallic/Silver Metallic
●	Medium Wedgewood Blue Metallic/Arizona Beige Metallic
●	Medium Wedgewood Blue Metallic/Silver Metallic
●	True Blue Metallic/Arizona Beige Metallic
●	True Blue Metallic/Silver Metallic
●	Black/Arizona Beige Metallic
●	Black/Silver Metallic
<b>Lariat</b>	
● ●	Oxford White
●	Arizona Beige Metallic
● ●	Red
● ●	Dark Toreador Red Metallic
● ●	Dark Green Satin Metallic
● ●	Medium Wedgewood Blue Metallic
● ●	True Blue Metallic
●	Silver Metallic
●	Dark Shadow Grey Metallic
●	Dark Stone Metallic*
● ●	Black
<b>Lariat Two-Tone</b>	
●	Oxford White/Arizona Beige Metallic
●	Oxford White/Silver Metallic
●	Arizona Beige Metallic/Black (SRW only)
●	Dark Toreador Red Metallic/Arizona Beige Metallic
●	Dark Toreador Red Metallic/Silver Metallic
●	Medium Wedgewood Blue Metallic/Arizona Beige Metallic
●	Medium Wedgewood Blue Metallic/Silver Metallic
●	True Blue Metallic/Arizona Beige Metallic
●	True Blue Metallic/Silver Metallic
●	Dark Shadow Grey Metallic/Black
●	Dark Stone Metallic*/Arizona Beige Metallic
●	Black/Arizona Beige Metallic
●	Black/Silver Metallic
<b>King Ranch Package</b>	
●	Oxford White/Arizona Beige Metallic**
●	Dark Green Satin Metallic/Arizona Beige Metallic**
●	Dark Copper Metallic*/Arizona Beige Metallic**

\*New for 2005. \*\*Castaño leather-trimmed seats.

Medium Flint	
<b>Black</b>	
<b>XLT Sport Package</b>	
● ●	Oxford White
● ●	Red
● ●	True Blue Metallic
● ●	Dark Shadow Grey Metallic
● ●	Black
<b>Dark Flint/Black</b>	
<b>Ford Harley-Davidson™ F-Series</b>	
●	Black Monotone with Orange Graphic
●	Black with Dark Toreador Red Flames
●	True Blue Metallic with Medium Wedgewood Blue Flames

## EXTERIOR COLORS



Oxford White



Arizona Beige Metallic



Red



Dark Toreador Red Metallic



Dark Green Satin Metallic



Medium Wedgewood Blue Metallic



True Blue Metallic



Silver Metallic



Dark Shadow Grey Metallic



Dark Stone Metallic



Black



Dark Copper Metallic

Ford uses clearcoat paint for beauty and protection. Colors shown are representative only. Not all colors are available on all models. See your dealer for actual paint/trim options.



Get the ride you want. Whether you plan to lease or finance, you'll find the choices that are right for you at Ford Credit. Ask your Ford Dealer for details or check us out at [fordcredit.com](http://fordcredit.com).



For a purchase or lease, the Ford Extended Service Plan (ESP) gives you "Peace-of-Mind" protection designed to cover key vehicle components and protect you from the cost of unexpected repairs. Ask your dealer for an ESP backed by Ford Motor Company and honored at all Ford dealerships.

Choose the insurance program that's designed for your vehicle - Ford Motor Company Insurance Services. Our program helps you receive the rates and service you deserve. Call 1-877-367-3847 or visit us at [fordvip.com](http://fordvip.com) for a no-obligation quote. Insurance offered by American Road Services Company (in CA, American Road Insurance Agency), a licensed agency and subsidiary of Ford Motor Company.

## BEST-IN-CLASS

- BEST HORSEPOWER
- BEST GAS TORQUE
- UNSURPASSED DIESEL HORSEPOWER
- MOST PULLING POWER
- LONGEST-LASTING DIESEL ENGINE
- BEST BRAKING PERFORMANCE
- HIGHEST GVWR
- BEST PAYLOAD
- UNSURPASSED GCWR
- BEST CONVENTIONAL TOWING
- BEST 5TH-WHEEL TOWING
- MOST INTERIOR ROOM

## FIRST-IN-CLASS

- FULLY INTEGRATED TRAILER BRAKE CONTROLLER
- 15,000-LB.-RATED 2-1/2" HITCH RECEIVER
- UPFITTER SWITCHES
- "DRIVER'S" GLOVE COMPARTMENT

## CLASS EXCLUSIVES

- NEW 5.4L TRITON™ V8 – 3-VALVE WITH VARIABLE CAM TIMING
- NEW 6.8L TRITON V10 – 3-VALVE WITH SEFI
- FORD HARLEY-DAVIDSON™ F-SERIES SUPER DUTY
- FORD KING RANCH F-SERIES SUPER DUTY
- POWER MOONROOF

©2004 Ford Motor Company 05FSDCAT  
Litho in USA on recycled paper (20% post consumer)

[fordvehicles.com](http://fordvehicles.com)