

ISUZU



**FOR ADDITIONAL INFORMATION
ON ISUZU'S FULL LINE OF LOW CAB
FORWARD TRUCKS PLEASE VISIT**

**WWW.ISUZUCV.COM
OR CALL (866) 441-9638**



**SCAN TO ACCESS A
DIGITAL COPY OF THE
2025 MY FULL-LINE
POCKET GUIDE**

ISUZU

All photographs, illustrations, equipment, and technical data in this brochure are based on the latest information available at the time of publication. Isuzu Commercial Truck of America, Inc. reserves the right to make changes at any time, without notice, in prices, colors, materials, equipment, specifications, and models, and to discontinue models of equipment. Isuzu vehicles are assembled from component parts manufactured by Isuzu Motors Limited, its affiliated companies, and by independent suppliers who manufacture such components to Isuzu's exacting standards for quality, performance, and safety. Some vehicles are shown with optional equipment. Some equipment is dealer installed. Visit your authorized Isuzu dealer for warranty and other details. Android Auto is a trademark of Google LLC. Apple Carplay is a registered trademark of Apple Inc. Bluetooth is a registered trademark of Bluetooth SIG, Inc. SiriusXM is a trademark of Sirius XM Radio Inc. HD Radio is a registered trademark of iBiquity. Facebook is a registered trademark of Meta. Instagram is a registered trademark of Meta. X is a trademark of X Corp. YouTube is a registered trademark of Google Inc. Neither Isuzu Commercial Truck of America, Inc. nor Isuzu Motors Limited are sponsored by or affiliated with these platforms. FleetValue is a registered trademark of Isuzu Commercial Truck of America, Inc. Copyright © 2024 Isuzu Commercial Truck of America, Inc.

2025 MY FULL-LINE POCKET GUIDE



CELEBRATING 40 YEARS OF ISUZU TRUCKS IN AMERICA



Starting in 1984 with the KS22, Isuzu trucks have been the backbone of industries across the United States. Reliably delivering goods and services, they have consistently provided owners with the peace of mind that their trucks are designed for minimal downtime and maximum productivity.

In two short years, Isuzu became the best-selling low cab forward truck in America – and still is. The unrivaled success of our trucks have built a legacy, not just for quality, but also the ownership experience. We do not take our customers' trust in us lightly, and invite you to discover what inspires such loyalty—and why Isuzu trucks are a favorite in every industry they serve.

Today, More Than Ever, Our Commitment Drives Us. Isuzu's commitment to bringing you the most capable, durable, and efficient work trucks has never been stronger. Embracing innovation is key to our success. Our trucks continue to evolve, and cater to the ever-changing needs of our customers and their environments. The 2025 NRR EV and N-Series Diesel trucks are a testament to this commitment.

With a zero-emission drivetrain, standard ADAS, and standard driver and outboard passenger SRS frontal airbags, the Isuzu NRR EV is designed to be the work truck of the future. Customers will appreciate the quietness of the powertrain and up to 235 miles of range coupled with the maneuverability and visibility that Isuzu trucks are known for.

The 2025 N-Series Diesel also boasts a new cab design. The new grille, LED headlamps, and bumper give the fascia a sleeker modern appearance. The fresh interior boasts new driving conveniences like steering wheel controls, a new color MID with an LED screen, and advanced safety like an optional ADAS package and standard driver and outboard passenger SRS frontal airbags.

Over the years, challenges have come and gone. They were not roadblocks, but mere stepping stones on the journey that made us better for the customers and industries we serve. In the years ahead, we will continue to embrace each obstacle as an opportunity to improve, an opportunity to triumph, an opportunity to make lasting relationships. We're Isuzu and we're committed to pioneering the next 40 years with both you and your work in mind.

N-SERIES GAS



NPR

CLASS 3



STANDARD CAB



CREW CAB

GVWR
12,000 lb.

GCWR
18,000 lb.

PAYLOADS
6,115 - 6,846 lb.

6.6L 8-CYLINDER ENGINE | **8** SPEED AUTOMATIC TRANSMISSION
350 HP / 425 LB-FT TORQUE

NPR-HD

CLASS 4



STANDARD CAB



CREW CAB

GVWR
14,500 lb.

GCWR
20,500 lb.

PAYLOADS
8,277 - 8,986 lb.

6.6L 8-CYLINDER ENGINE | **8** SPEED AUTOMATIC TRANSMISSION
350 HP / 425 LB-FT TORQUE

NQR

CLASS 5



STANDARD CAB



CREW CAB

GVWR
17,950 lb.

GCWR
23,950 lb.

PAYLOADS
11,407 - 12,064 lb.

6.6L 8-CYLINDER ENGINE | **ALLISON 1000 RDS** TRANSMISSION
350 HP / 425 LB-FT TORQUE

NRR

CLASS 5



STANDARD CAB



CREW CAB

GVWR
19,500 lb.

GCWR
25,500 lb.

PAYLOADS
12,954 - 13,611 lb.

6.6L 8-CYLINDER ENGINE | **ALLISON 1000 RDS** TRANSMISSION
350 HP / 425 LB-FT TORQUE

N-SERIES GAS

	NPR (Class 3)	NPR-HD (Class 4)
GVWR	12,000 lbs.	14,500 lbs.
GCWR	18,000 lbs.	20,500 lbs.
BODY/PAYLOAD ALLOWANCE		
• STANDARD	6,667 lbs. - 6,846 lbs.	8,826 lbs. - 8,986 lbs.
• CREW CAB	6,115 lbs. - 6,166 lbs.	8,277 lbs. - 8,318 lbs.
GAWR (FRONT/REAR)	4,860 lbs./8,840 lbs.	6,630 lbs./11,020 lbs.
AXLE CAPACITY (FRONT/REAR)	6,830 lbs./14,550 lbs.	6,830 lbs./14,550 lbs.
REAR AXLE RATIO	3.909	4.100
SUSPENSION (FRONT/REAR)		
• TYPE	Tapered/Multi-Leaf	Tapered/Multi-Leaf
• CAPACITY	6,830 lbs./12,900 lbs.	6,830 lbs./12,900 lbs.
ENGINE		
• TYPE	GMPT L8T (Gen V) Gasoline V8	GMPT L8T (Gen V) Gasoline V8
• DISPLACEMENT	6.6L (400 cu. in.)	6.6L (400 cu. in.)
• HORSEPOWER	350hp @ 4,500 rpm	350hp @ 4,500 rpm
• TORQUE	425 lb.-ft. @ 3,800 rpm	425 lb.-ft. @ 3,800 rpm
TRANSMISSION	8L90 Hydra-Matic 8-speed automatic with lock-up converter and overdrive	8L90 Hydra-Matic 8-speed automatic with lock-up converter and overdrive
BRAKES		
• SERVICE	Vacuum+Power Assist/ Hydraulic with 4-Channel ABS/Front and Rear Disc	Vacuum+Power Assist/ Hydraulic with 4-Channel ABS/Front and Rear Disc
LIMITED SLIP DIFFERENTIAL	Optional	Optional
ALTERNATOR	170-amp	170-amp
BATTERIES	1 Maintenance-Free Group 31 750-CCA	1 Maintenance-Free Group 31 750-CCA
TIRES LRR (Low Rolling Resistance)	215/85R16E (10-pr)	225/70R19.5G (14-pr)
FUEL TANK	38.6-gal. in-frame	38.6-gal. in-frame

N-SERIES GAS

NQR (Class 5)

NRR (Class 5)



GVWR	17,950 lbs.	19,500 lbs.
GCWR	23,950 lbs.	25,500 lbs.
BODY/PAYLOAD ALLOWANCE		
• STANDARD	11,967 lbs. - 12,064 lbs.	13,514 lbs. - 13,611 lbs.
• CREW CAB	11,407 lbs. - 11,471 lbs.	12,954 lbs. - 13,018 lbs.
GAWR (FRONT/REAR)	6,830 lbs./13,660 lbs.	7,275 lbs./14,460 lbs.
AXLE CAPACITY (FRONT/REAR)	6,830 lbs./14,550 lbs.	7,275 lbs./14,550 lbs.
REAR AXLE RATIO	5.375	5.375
SUSPENSION (FRONT/REAR)		
• TYPE	Tapered/Multi-Leaf	Tapered/Multi-Leaf
• CAPACITY	8,440 lbs./14,550 lbs.	8,440 lbs./14,550 lbs.
ENGINE		
• TYPE	GMPT L8T (Gen V) Gasoline V8	GMPT L8T (Gen V) Gasoline V8
• DISPLACEMENT	6.6L (400 cu. in.)	6.6L (400 cu. in.)
• HORSEPOWER	350hp @ 4,500 rpm	350hp @ 4,500 rpm
• TORQUE	425 lb.-ft. @ 3,800 rpm	425 lb.-ft. @ 3,800 rpm
TRANSMISSION	Allison 1000 RDS 6-speed automatic	Allison 1000 RDS 6-speed automatic
BRAKES		
• SERVICE	Vacuum+Power Assist/ Hydraulic with 4-Channel ABS/Front and Rear Disc	Vacuum+Power Assist/ Hydraulic with 4-Channel ABS/Front and Rear Disc
LIMITED SLIP DIFFERENTIAL	Optional	Optional
ALTERNATOR	170-amp	170-amp
BATTERIES	1 Maintenance-Free Group 31 750-CCA	1 Maintenance-Free Group 31 750-CCA
TIRES LRR (Low Rolling Resistance)	225/70R19.5G (14-pr)	225/70R19.5G (14-pr)
FUEL TANK	38.6-gal. in-frame	38.6-gal. in-frame

N-SERIES GAS

STANDARD CAB

Wheelbase (in.)	Cab to Axle (in.)	Cab to End of Frame (in.)
109.0†	86.5	129.6
132.5	110	153.1
150.0	127.5	170.6
176.0	153.5	196.6

OAL (in.)	OAH (in.)	OAW (in.)	Body Length (ft.)
200.5	92.4*	81.3	10-12
224.0	92.4*	81.3	12-14
241.5	92.4*	81.3	16-18
267.5	92.4*	81.3	18-20

CREW CAB

150.0	88.5	131.6
176.0	114.5	157.6

241.5	92.4**	81.3	12
267.5	92.4**	81.3	16

†NPR, NPR-HD only

*NPR Standard Cab is 90 in. and NPR-HD Standard Cab is 90.9 in.

**NPR and NPR-HD Crew Cab is 91.1 in.

*NPR Standard Cab is 90 in. and NPR-HD Standard Cab is 90.9 in.

**NPR and NPR-HD Crew Cab is 91.1 in.

Frame Height	
Standard Cab	33*
Crew Cab	33*
Frame Rail Width	
Standard Cab	33.5
Crew Cab	33.5

Back of Cab	
Standard Cab	7.7
Crew Cab	5
Afterframe	
Standard Cab	43.1
Crew Cab	43.1

*NPR is 31.8

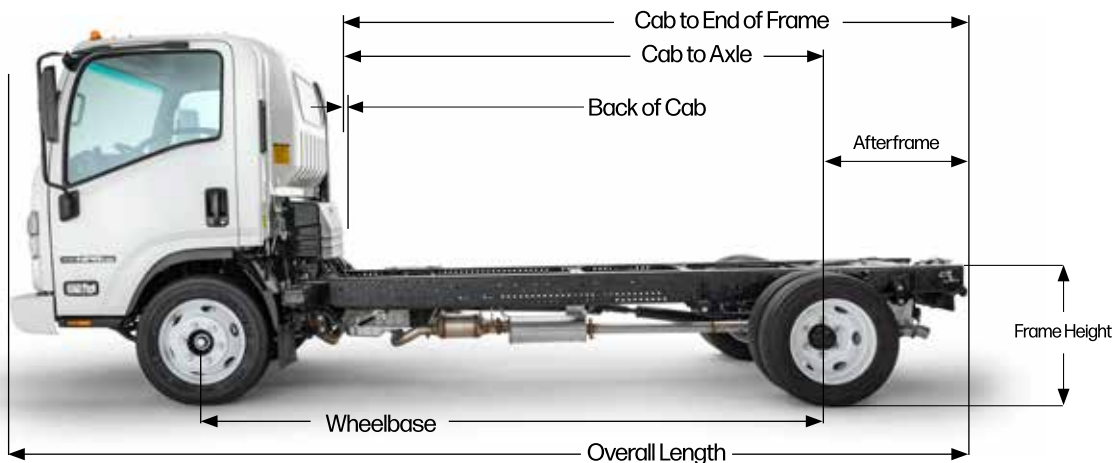

N-SERIES GAS

MEASUREMENTS

STANDARD CAB

	NPR		
Wheelbase (in.)	Curb Weight (lbs.)	Body Payload (lbs.)	Model Codes
109.0	5,154	6,846	1C1
132.5	5,256	6,744	1C2
150.0	5,285	6,715	1C3
176.0	5,333	6,667	1C4

NPR-HD		
Curb Weight (lbs.)	Body Payload (lbs.)	Model Codes
5,514	8,986	1F1
5,593	8,907	1F2
5,633	8,867	1F3
5,674	8,826	1F4

CREW CAB

150.0	5,834	6,166	1D3
176.0	5,885	6,115	1D4

6,182	8,318	1G3
6,223	8,277	1G4

STANDARD CAB

	NQR		
Wheelbase (in.)	Curb Weight (lbs.)	Body Payload (lbs.)	Model Codes
132.5	5,886	12,064	1R2
150.0	5,929	12,021	1R3
176.0	5,983	11,967	1R4

NRR		
Curb Weight (lbs.)	Body Payload (lbs.)	Model Codes
5,889	13,611	1U2
5,932	13,568	1U3
5,986	13,514	1U4

CREW CAB

150.0	6,479	11,471	1S3
176.0	6,543	11,407	1S4

6,482	13,018	1V3
6,546	12,954	1V4

ACCESSORIES & OPTIONS

- AGM Battery
- Air Deflector
- Back Up Alarm
- Engine Block Heater and Receptacle
- Chrome Grille
- Fire Extinguisher and Reflector Kit
- Front Fascia Protector
- High-Visibility Seatbelts
- Keyless Entry
- Mobileye®
- Limited Slip Differential
- Power Heated Mirrors
- Touchscreen Audio System with Back Up Camera
- Seat Covers
- Spare Keys (2 additional keys)
- Speed Limiting to 65 mph
- Suspension Seat
- 102-in. Side Mirror Bracket



High-Visibility Seatbelts



Block Heater



Touchscreen Audio



AGM Battery

NEW VEHICLE LIMITED WARRANTY

Warranty Limitations: Time or Mileage, Whichever Comes First

New Truck Warranty	Time in Years	Vehicle Miles
Basic	3	36,000
Engine Transmission - 8L-90 Drive Axle	5	75,000
Frame Rails	3 5*	36,000 Unlimited*
Corrosion (Rust Through)	4	Unlimited
Roadside Assistance	3 5†	36,000 75,000†
Emission Warranty	Time in Years	Vehicle Miles
Emissions Control System - Federal	5	50,000
Emission Control System (NPR model) - California**	3 7	50,000 70,000
GHG Emission	5	50,000
Tire	2	24,000

* After 3 years or 36,000 miles (whichever comes first), labor and parts coverage is 50% for up to 5 years.

† Tows related to emissions issues may be covered for up to 5 years or 75,000 miles (whichever comes first).

**Please see warranty booklet for coverage details.

The warranty coverages are determined by the mileage of the vehicle and the number of years from the delivery date. The warranty coverages are limited by whichever occurs first. Please see your authorized Isuzu dealer for warranty details.

EXTENDED WARRANTY

60 MONTHS/150,000 MILES

(See Your Authorized Isuzu Dealer for Additional Extended Warranty Coverages)

ENGINE

- All internally lubricated parts including, but not limited to, cylinder block, head, oil pan, thermostat housing, flywheel, intake manifolds, and the following internal parts: Oil pump, pistons with rings, crankshaft and bearings, connecting rods and bearings, head bolts, cylinder head gasket, intake and exhaust valves, rocker arm assembly, camshaft actuator, camshaft, front and rear main seals

DRIVE AXLE

Differential, axle shafts, all seals and bearings

TRANSMISSION

Transmission case and all internal parts

ROADSIDE ASSISTANCE

Roadside assistance and towing to the nearest dealer for covered repairs on the vehicle at no additional charge

NEW VEHICLE LIMITED WARRANTY

Warranty Limitations: Time or Mileage, Whichever Comes First

New Truck Warranty	Time in Years	Vehicle Miles
Basic	3	36,000
Engine Drive Axle	5	75,000
Transmission - Allison*	5	Unlimited
Frame Rails	3 5**	36,000 Unlimited**
Corrosion (Rust Through)	4	Unlimited
Roadside Assistance	3 5†	36,000 75,000†
Emission Warranty	Time in Years	Vehicle Miles
Federal Defect	5	50,000
GHG Emission	5	50,000
Tire	2	24,000

*The Allison automatic transmission is warranted separately by Allison Transmission. The warranty coverages are determined by the mileage of the vehicle and the number of years from the delivery date. The warranty coverages are limited by whichever occurs first. Please see your authorized Isuzu dealer for warranty details.

**After 3 years or 36,000 miles (whichever comes first), labor and parts coverage is 50% for up to 5 years.

†Tows related to emissions issues may be covered for up to 5 years or 75,000 miles (whichever comes first).

EXTENDED WARRANTY

60 MONTHS/150,000 MILES

(See Your Authorized Isuzu Dealer for Additional Extended Warranty Coverages)

ENGINE

- All internally lubricated parts including, but not limited to, cylinder block, head, oil pan, thermostat housing, flywheel, intake manifolds, and the following internal parts: Oil pump, pistons with rings, crankshaft and bearings, connecting rods and bearings, head bolts, cylinder head gasket, intake and exhaust valves, rocker arm assembly, camshaft actuator, camshaft, front and rear main seals

DRIVE AXLE

Differential, axle shafts, all seals and bearings

ROADSIDE ASSISTANCE

Roadside assistance and towing to the nearest dealer for covered repairs on the vehicle at no additional charge

*The transmission is not covered under this extended warranty.

N-SERIES DIESEL



NPR-HD

CLASS 4



STANDARD CAB



CREW CAB

GVWR 14,500 lb. | **GCWR** 20,500 lb. | **PAYLOADS** 7,725- 8,470 lb.

5.2L I4 TURBOCHARGED 215 HP / 452LB-FT TORQUE | **6 SPEED** AUTOMATIC TRANSMISSION

NRR DERATE

CLASS 5



STANDARD CAB



CREW CAB

GVWR 17,950 lb. | **GCWR** 23,950 lb. | **PAYLOADS** 10,659- 11,420 lb.

5.2L I4 TURBOCHARGED 215 HP / 452LB-FT TORQUE | **6 SPEED** AUTOMATIC TRANSMISSION

NPR-XD

CLASS 4



STANDARD CAB



CREW CAB

GVWR 16,000 lb. | **GCWR** 22,000 lb. | **PAYLOADS** 8,831- 9,576 lb.

5.2L I4 TURBOCHARGED 215 HP / 452LB-FT TORQUE | **6 SPEED** AUTOMATIC TRANSMISSION

NRR

CLASS 5



STANDARD CAB



CREW CAB

GVWR 19,500 lb. | **GCWR** 25,500 lb. | **PAYLOADS** 12,209- 12,970 lb.

5.2L I4 TURBOCHARGED 215 HP / 452LB-FT TORQUE | **6 SPEED** AUTOMATIC TRANSMISSION

	NPR-HD	NPR-XD
GVWR	14,500 lbs.	16,000 lbs.
GCWR	20,500 lbs.	22,000 lbs.
BODY/PAYLOAD ALLOWANCE		
• STANDARD	8,327 lbs. - 8,470 lbs.	9,430 lbs. - 9,576 lbs.
• CREW CAB	7,725 lbs. - 7,776 lbs.	8,831 lbs. - 8,879 lbs.
GAWR (FRONT/REAR)	5,360 lbs./9,880 lbs.	6,630 lbs./11,020 lbs.
AXLE CAPACITY (FRONT/REAR)	6,830 lbs./11,020 lbs.	6,830 lbs./11,020 lbs.
REAR AXLE RATIO	4.556	4.777
SUSPENSION (FRONT/REAR)		
• TYPE	Tapered/Multi-Leaf	Tapered/Multi-Leaf
• CAPACITY	6,830 lbs./9,880 lbs.	8,440 lbs./14,308 lbs.
ENGINE		
• TYPE	Isuzu 4HK1-TC turbocharged intercooled diesel	Isuzu 4HK1-TC turbocharged intercooled diesel
• DISPLACEMENT	5.2L (317 cu. in.)	5.2L (317 cu. in.)
• HORSEPOWER	215hrp @ 2,500 rpm	215hrp @ 2,500 rpm
• TORQUE	452 lb.-ft. @ 1,850 rpm	452 lb.-ft. @ 1,850 rpm
TRANSMISSION	Aisin A465id 6-speed auto. with double overdrive and lock-up 2nd-6th gears	Aisin A465id 6-speed auto. with double overdrive and lock-up 2nd-6th gears
BRAKES		
• SERVICE	Vacuum+Power Assist/Hydraulic with 4-Channel ABS/Front and Rear Disc Standard	Vacuum+Power Assist/Hydraulic with 4-Channel ABS/Front and Rear Disc Standard
• EXHAUST		
STABILITY CONTROL	Standard - Electronic Stability Control (ESC) with Anti-Slip Regulation (ASR)	Standard - Electronic Stability Control (ESC) with Anti-Slip Regulation (ASR)
ALTERNATOR	140-amp	140-amp
BATTERIES	2 Maintenance-Free Group 31 750-CCA	2 Maintenance-Free Group 31 750-CCA
TIRES LRR (Low Rolling Resistance)	215/85R16E (10-pr)	225/70R19.5F (12-pr)
FUEL TANK		
• STANDARD	30-gal. in-frame	30-gal. in-frame

N-SERIES DIESEL

CLASS 5

	<i>NRR DERATE</i>	<i>NRR</i>
GVWR	17,950 lbs.	19,500 lbs.
GCWR	23,950 lbs.	25,500 lbs.
BODY/PAYLOAD ALLOWANCE <ul style="list-style-type: none">• STANDARD• CREW CAB	11,271 lbs. - 11,420 lbs. 10,659 lbs. - 10,710 lbs.	12,821 lbs. - 12,970 lbs. 12,209 lbs. - 12,260 lbs.
GAWR (FRONT/REAR)	6,830 lbs./12,980 lbs.	7,275 lbs./13,660 lbs.
AXLE CAPACITY (FRONT/REAR)	7,275 lbs./14,550 lbs.	7,275 lbs./14,550 lbs.
REAR AXLE RATIO	5.571	5.571
SUSPENSION (FRONT/REAR) <ul style="list-style-type: none">• TYPE• CAPACITY	Tapered/Multi-Leaf 8,440 lbs./14,550 lbs.	Tapered/Multi-Leaf 8,440 lbs./14,550 lbs.
ENGINE <ul style="list-style-type: none">• TYPE• DISPLACEMENT• HORSEPOWER• TORQUE	Isuzu 4HK1-TC turbocharged intercooled diesel 5.2L (317 cu. in.) 215hrp @ 2,500 rpm 452 lb.-ft. @ 1,850 rpm	Isuzu 4HK1-TC turbocharged intercooled diesel 5.2L (317 cu. in.) 215hrp @ 2,500 rpm 452 lb.-ft. @ 1,850 rpm
TRANSMISSION	Aisin A465id 6-speed auto. with double overdrive and lock-up 2nd-6th gears	Aisin A465id 6-speed auto. with double overdrive and lock-up 2nd-6th gears
BRAKES <ul style="list-style-type: none">• SERVICE• EXHAUST	Vacuum+Power Assist/ Hydraulic with 4-Channel ABS/Front and Rear Disc Standard	Vacuum+Power Assist/ Hydraulic with 4-Channel ABS/Front and Rear Disc Standard
STABILITY CONTROL	Standard - Electronic Stability Control (ESC) with Anti-Slip Regulation (ASR)	Standard - Electronic Stability Control (ESC) with Anti-Slip Regulation (ASR)
ALTERNATOR	140-amp	140-amp
BATTERIES	2 Maintenance-Free Group 31 750-CCA	2 Maintenance-Free Group 31 750-CCA
TIRES LRR (Low Rolling Resistance)	225/70R19.5F (12-pr)	225/70R19.5F (12-pr)
FUEL TANK <ul style="list-style-type: none">• STANDARD	30-gal. in-frame	30-gal. in-frame

N-SERIES DIESEL

STANDARD CAB

Wheelbase (in.)	Cab to Axle (in.)	Cab to End of Frame (in.)
109.0	86.5	129.6
132.5	110	153.1
150.0	127.5	170.6
176.0	153.5	196.6
200.0 [†]	177.5	220.6
212.0 [†]	189.5	232.6

OAL (in.)	OAH (in.)	OAW (in.)	Body Length (ft.)
195.7	92.9*	81.3	10-12
219.2	92.9*	81.3	12-14
236.7	92.9*	81.3	16-18
262.7	92.9*	81.3	18-20
286.7	92.9	81.3	22
298.7	92.9	81.3	24

CREW CAB

150.0	88.5	131.6
176.0	114.5	157.6

236.7	92.9*	81.3	12
262.7	92.9*	81.3	16

[†]NRR only

*NPR-HD is 91.3 in.

Frame Height	
NPR-HD	31.6
NPR-XD & NRR	33.5
Frame Rail Width	
Standard Cab	33.5
Crew Cab	33.5

Back of Cab	
Standard Cab	7.7
Crew Cab	5.3
Afterframe	
Standard Cab	43.1
Crew Cab	43.1

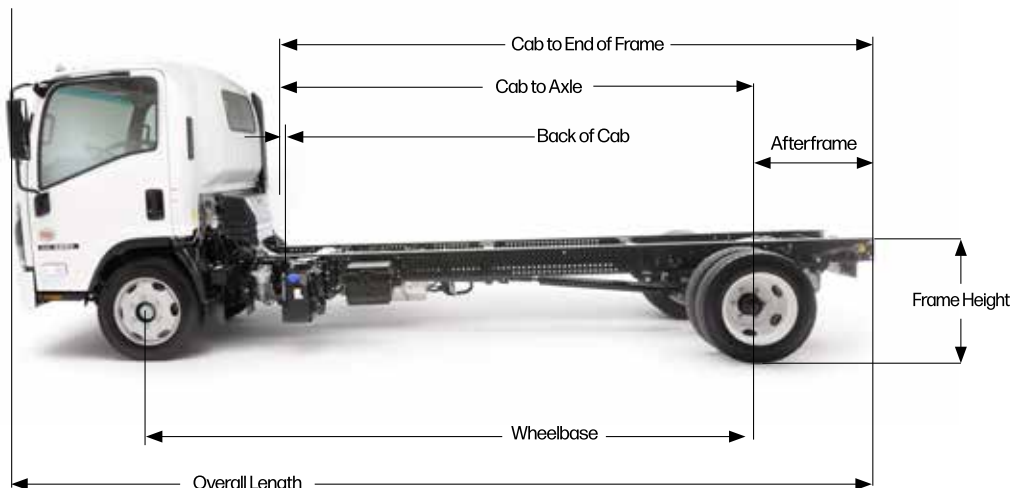

N-SERIES DIESEL

MEASUREMENTS

STANDARD CAB

NPR-HD			
Wheelbase (in.)	Curb Weight (lbs.)	Body Payload (lbs.)	Model Codes
109.0	6,030	8,470	3F1
132.5	6,100	8,400	3F2
150.0	6,133	8,367	3F3
176.0	6,173	8,327	3F4

NPR-XD		
Curb Weight (lbs.)	Body Payload (lbs.)	Model Codes
6,424	9,576	3Y1
6,497	9,503	3Y2
6,528	9,472	3Y3
6,570	9,430	3Y4

CREW CAB

150.0	6,724	7,776	3G3
176.0	6,775	7,725	3G4

7,121	8,879	3Z3
7,169	8,831	3Z4

STANDARD CAB

NRR DERATE*			
Wheelbase (in.)	Curb Weight (lbs.)	Body Payload (lbs.)	Model Codes
109.0	6,530	11,420	N/A*
132.5	6,612	11,338	N/A*
150.0	6,632	11,318	N/A*
176.0	6,679	11,271	N/A*

NRR		
Curb Weight (lbs.)	Body Payload (lbs.)	Model Codes
6,530	12,970	3U1
6,612	12,888	3U2
6,632	12,868	3U3
6,679	12,821	3U4

CREW CAB

150.0	7,240	10,710	N/A*
176.0	7,291	10,659	N/A*

7,240	12,260	3V3
7,291	12,209	3V4

*NRR Derate is a PIO option.

ACCESSORIES & OPTIONS

- Advanced Driver Assistance System (ADAS) with Electronic Parking Brake
- AGM Batteries (825 CCA x 2)
- Air Deflector
- Back Up Alarm
- Engine Block and Oil Pan Heater with Receptacle
- Chrome Grille
- Derate GVWR to 17,950-lbs.
- Dual Fuel Tank
- Emergency Engine Shutdown
- Engine Idle Shutdown (3 or 5 minutes)
- Fire Extinguisher and Reflector Kit
- FMS Jumper Harness provides read-only CAN data for compatible telematics systems
- High-Visibility Seatbelts
- Keyless Entry
- LED Fog Lamps
- Lockable DEF Cap
- Power Heated Mirrors
- PTO Switch
- Touchscreen Audio System with Back Up Camera
- Seat Covers
- Spare Keys (2 additional keys)
- Speed Limiting to 58, 65, 68 or 70 mph
- Suspension Seat
- Vertical Exhaust
- 102-in. Side Mirror Bracket



Electronic Parking Brake



ADAS System



Lockable DEF Cap

N-SERIES DIESEL

NEW VEHICLE LIMITED WARRANTY

Warranty Limitations: Time or Mileage, Whichever Comes First

New Truck Warranty	Time in Years	Vehicle Miles
Basic	3	Unlimited
Engine - Isuzu	3	Unlimited
Transmission - Aisin A465ID Drive Axle Driveshaft Front Axle I Beam Crossmembers Flywheel Housing	3	Unlimited
Frame Rails	3 5*	Unlimited Unlimited*
Corrosion (Rust Through)	4	Unlimited
Roadside Assistance	3 5†	Unlimited 100,000†
Emission Defect	Time in Years	Vehicle Miles
Emission Defect Warranty	5	110,000
GHG Emission	5	50,000
Tire	2	24,000

*After 3 years labor and parts coverage is 50% for up to 5 years.

†Tows related to emissions issues may be covered for up to 5 years or 100,000 miles (whichever comes first).

The warranty coverages are determined by the mileage of the vehicle and the number of years from the delivery date. The warranty coverages are limited by whichever occurs first. Please see your authorized Isuzu dealer for warranty details.

EXTENDED WARRANTY

60 MONTHS / 200,000 MILES

(See Your Authorized Isuzu Dealer for Additional Extended Warranty Coverages)

ENGINE

- All internally lubricated parts including, but not limited to, cylinder block, cylinder head, oil pan, oil cooler, thermostat housing, flywheel, intake manifolds, and the following internal parts: Timing gear, Front and main seals, Oil pump, pistons with rings, liners, crankshaft and bearings, connecting rods and bearings, head bolts, cylinder head gasket, intake and exhaust valves, rocker arm assembly, camshaft and bearings.

DRIVE AXLE

Differential, axle shafts, all seals and bearings

TRANSMISSION

Transmission case and all internal parts

ROADSIDE ASSISTANCE

Roadside assistance and towing to the nearest dealer for covered repairs on the vehicle at no additional charge



NRR EV

NRR EV

CLASS 5



STANDARD CAB

GVWR | **BODIES** | **PAYLOADS**
 19,500 lb. | Up To **20ft** | 9,882-12,951 lb.
ELECTRIC MOTOR 150 kW /
MAX POWER / TORQUE OUTPUT 280 lb-ft.

BATTERY CONFIGURATIONS

# Battery Packs	Battery Capacity (kWh)	Wheelbase (in.)	Range (mi.)*
3	60	132.5	41-80
		150	
		176	
5	100	132.5	68-130
		150	
		176	
7	140	176	95-180
9	180	176	122-235



3 Battery Packs



5 Battery Packs



7 Battery Packs



9 Battery Packs

*All figures are calculated estimates and based on a fully charged battery. For comparison purposes only. Battery capacity decreases with time and use. Actual range will vary based on a number of factors, including number of battery packs, vehicle options, driving conditions and habits, vehicle and battery's condition, and outside temperature.

GVWR	19,500 lbs.
BODY/PAYLOAD ALLOWANCE	9,882 lbs. - 12,951 lbs.
GAWR (FRONT/REAR)	7,275 lbs./14,460 lbs.
ELECTRIC MOTOR	ZF CeTrax Lite 3-phase AC motor: motor sub-assembly includes an integrated DC-AC inverter, single speed reduction gear, and motor control unit
MAX POWER / TORQUE OUTPUT	150 kW / 280 lb-ft.
OPERATING VOLTAGE	350 volts
HIGH VOLTAGE BATTERY PACKS	Liquid cooled lithium-ion high voltage battery packs: each pack features 20 kWh of battery capacity
REGENERATIVE BRAKING	Adjustable regenerative braking with multiple strength levels using the steering wheel stalk switch
AC/DC CHARGING	AC charging from SAEJ1772 chargers up to 19.2 kW (limited to 7.2 kW on 60 kWh chassis) DC fast charging from CCS1 chargers up to 80 kW

ELECTRICAL	Two 12-volt (Group 34) 700 CCA
WHEELS	19.5 x 6.0 6-hole disc wheels, painted white
TIRES	225/70R-19.5 LRR tubeless steel belted radials, all season, front and rear
BRAKES	Dual circuit power assisted hydraulic 4-channel anti-lock service brake system with electronic brake distribution for load proportioning of the front and rear disc brakes, and a driveshaft mounted drum type electronically actuated parking brake
FRAME	Ladder type channel section straight frame rail 33.5-in. wide through the total length of the frame; yield strength 54,800 psi, section modulus 6.65 cubic in, RBM 364,420 lb-in per rail



Wheelbase (in.)	Cab to Axle (in.)	Cab to End of Frame (in.)
132.5	110	153.1
150.0	127.5	170.6
176.0	153.5	196.6

OAL (in.)	OAH (in.)	OAW (in.)	Body Length (ft.)
219.2	92.9	81.3	12-14
236.7	92.9	81.3	16-18
262.7	92.9	81.3	18-20

WB (in.)	BATTERY PACKS / kWh	BOC	FRAME HEIGHT
132.5	3 / 60	77 - in.	33.5 - in.
150	3 / 60		
176	3 / 60		
132.5	5 / 100		
150	5 / 100		
176	5 / 100		
176	7 / 140		
176	9 / 180		

WB (in.)	CURB WEIGHTS (lbs.)			PAYLOAD (lbs.)
	FRONT	REAR	TOTAL	
132.5	4139	2410	6549	12951
150	4256	2346	6602	12898
176	4452	2247	6699	12801
132.5	4547	3016	7563	11937
150	4734	2882	7616	11884
176	5010	2706	7716	11784
176	5268	3416	8684	10816
176	5548	4070	9618	9882

Frame Rail Width	33.5
------------------	------

Afterframe	431
------------	-----

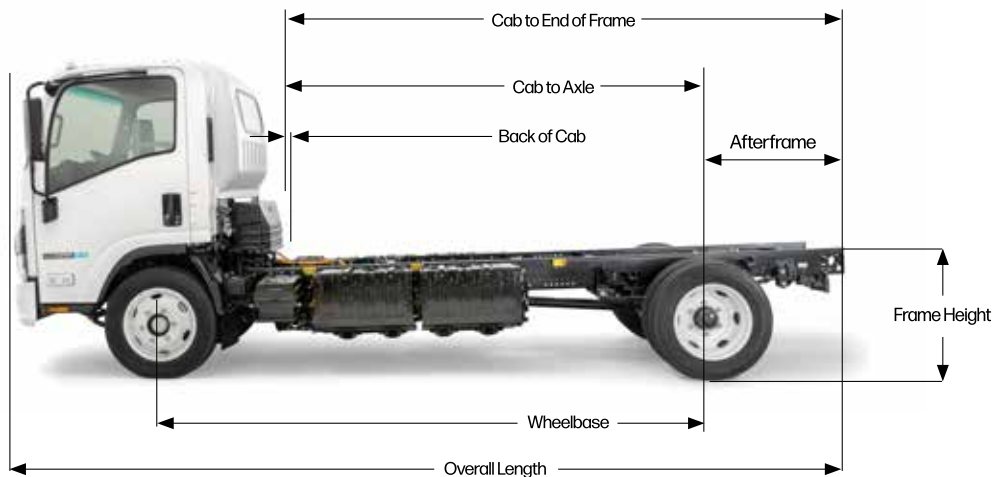

ACCESSORIES & OPTIONS

- Air Deflector
- Back Up Alarm
- Chrome Grille
- Derate GVWR to 17,950-lbs.
- Fire Extinguisher and Reflector Kit
- FMS Jumper Harness provides read-only CAN data for compatible telematics systems
- High-Visibility Seatbelts
- LED Fog Lamps
- Power Heated Mirrors
- Touchscreen Audio System with Back Up Camera
- Seat Covers
- Spare Keys (2 additional keys)
- 102-in. Side Mirror Bracket



LED Fog Lamps



Air Deflector



Touchscreen Audio



Fire Extinguisher and Reflector Kit



F-SERIES TRUCKS



FTR

CLASS 6



GVWR
25,950 lb.

GCWR
30,000 lb.

PAYLOADS
14,505-16,264 lb.

CUMMINS
B6.7L 260 HP
660 LB-FT TORQUE

ALLISON®
2550 RDS TRANSMISSION
INCLUDES PARK PAWL

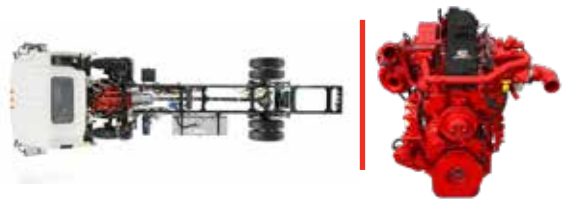

FVR DERATE

CLASS 6



GVWR
25,950 lb.

GCWR
33,000 lb.

PAYLOADS
14,405-15,939 lb.

CUMMINS
B6.7L 260 HP
660 LB-FT TORQUE

ALLISON®
2500 RDS TRANSMISSION

FVR

CLASS 7



GVWR
33,000 lb.

GCWR
33,000 lb.

PAYLOADS
21,455-22,989 lb.

CUMMINS
B6.7L 260 HP
660 LB-FT TORQUE

ALLISON®
2500 RDS TRANSMISSION

	FTR (Class 6)	FVR DERATE (Class 6)	FVR (Class 7)
GVWR/GCWR	25,950 lbs./30,000 lbs.	25,950 lbs./33,000 lbs.	33,000 lbs./33,000 lbs.
BODY/PAYLOAD ALLOWANCE	14,505 lbs. - 16,264 lbs.	14,405 lbs. - 15,939 lbs.	21,455 lbs. - 22,989 lbs.
GAWR (FRONT/REAR) LOW PRO	12,000 lbs./19,000 lbs. 11,000 lbs./19,000 lbs.	12,000 lbs./21,000 lbs. N/A	12,000 lbs./21,000 lbs. N/A
AXLE CAPACITY (FRONT/REAR)	12,000 lbs./19,000 lbs.	12,000 lbs./21,000 lbs.	12,000 lbs./21,000 lbs.
REAR AXLE RATIO			
• LOW PRO	4.88	N/A	N/A
• STANDARD	5.57	5.57	5.57
SUSPENSION (FRONT/REAR)			
• TAPERED/MULTI-LEAF (Std.)	12,000 lbs./21,000 lbs.	12,000 lbs./21,000 lbs.	12,000 lbs./21,000 lbs.
• TAPERED/AIR (Opt.)	12,000 lbs./23,000 lbs.	12,000 lbs./23,000 lbs.	12,000 lbs./23,000 lbs.
ENGINE			
• TYPE	Cummins B6.7 diesel	Cummins B6.7 diesel	Cummins B6.7 diesel
• DISPLACEMENT	6.7L (408 cu. in.)	6.7L (408 cu. in.)	6.7L (408 cu. in.)
• HORSEPOWER	260hp @ 2,400 rpm	260hp @ 2,400 rpm	260hp @ 2,400 rpm
• TORQUE	660 lb.-ft. @ 1,600 rpm	660 lb.-ft. @ 1,600 rpm	660 lb.-ft. @ 1,600 rpm
BRAKES			
• SERVICE	Full Air Dual Circuit with ABS S-CAM Drum Automatic Adjust Standard	Full Air Dual Circuit with ABS S-CAM Drum Automatic Adjust Standard	Full Air Dual Circuit with ABS S-CAM Drum Automatic Adjust Standard
• EXHAUST			
TRANSMISSION	Allison 2550 RDS 6-speed Automatic (Includes Park Pawl)	Allison 2500 RDS 6-speed Automatic (No Park Pawl)	Allison 2500 RDS 6-speed Automatic (No Park Pawl)
ALTERNATOR	160-amp	160-amp	160-amp
BATTERIES	2 Maintenance-Free Group 31 750-CCA	2 Maintenance-Free Group 31 750-CCA	2 Maintenance-Free Group 31 750-CCA
TIRES LRR (Low Rolling Resistance)	11R22.5G (14-pr)	11R22.5G (14-pr)	11R22.5G (14-pr)
• LOW PRO (Opt.)	255/70R22.5H (16-pr)	N/A	N/A
FUEL TANK (LH Side)	50 or 100-gal.	50 or 100-gal.	50 or 100-gal.

F-SERIES

Wheelbase (in.)	Cab to Axle (in.)	Cab to End of Frame (in.)	OAL (in.)	Afterframe	Body Length (ft.)
152	127	1929	2744	65.9	14-16
170	145	220	3015	75	16-18
188	163	247	3285	84.1	18-20
200	175	2649	3464	90	20-22
212	187	2831	3646	96.1	22-24
224	199	301	3825	102	22-26
236	211	3191	4006	108.1	24-28
248	223	337	4185	114	26-30

STANDARD TIRES

FH = Frame height (unladen) at E.O.F. (in.)	
Multi-Leaf	42.5
Air	38.2

FTR OAH Low Pro Tires Multi-leaf/Air (in.)
110.2/107

OAH Standard Tires Multi-leaf/Air (in.)
112/108.6

OAW (in.)
93.5

FTR LOW PRO TIRES

FH = Frame height (unladen) at E.O.F. (in.)	
Multi-Leaf	39.9
Air	35.9

Frame Rail Width (in.)	33.5
Back of Cab (in.)	10.4

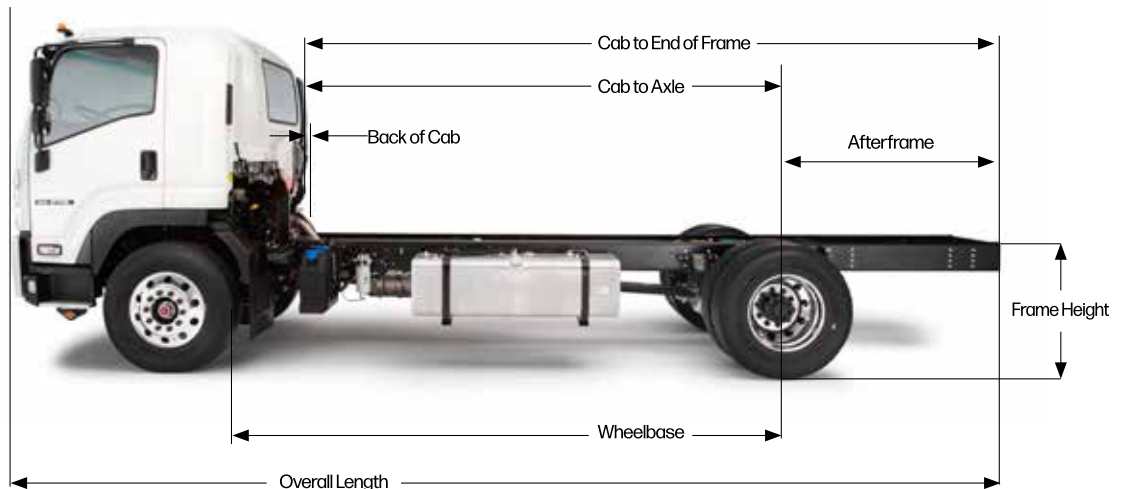

MEASUREMENTS

FTR

WB (in.)	Curb Weight (lbs.)	Body Payload (lbs.)	Model Codes
152	9,686	16,264	MT1
170	9,764	16,186	MT2
188	9,947	16,003	MT3
200	10,191	15,759	MT4
212	10,280	15,671	MT5
224	10,524	15,427	MT6
236	10,767	15,184	MT7
248	10,888	15,062	MT8

FVR DERATE

WB (in.)	Curb Weight (lbs.)	Body Payload (lbs.)	Model Codes
152	10,011	15,939	MW1
170	10,089	15,861	MW2
188	10,605	15,346	MW3
200	10,726	15,225	MW4
212	10,849	15,102	MW5
224	10,970	14,981	MW6
236	11,092	14,859	MW7
248	11,213	14,737	MW8



Curb weights display minimum weight.
Payload weights display maximum weight.

FVR

WB (in.)	Curb Weight (lbs.)	Body Payload (lbs.)	Model Codes
152	10,011	22,989	MV1
170	10,089	22,911	MV2
188	10,605	22,396	MV3
200	10,726	22,275	MV4
212	10,849	22,152	MV5
224	10,970	22,031	MV6
236	11,092	21,909	MV7
248	11,213	21,787	MV8

Curb weights display minimum weight.
Payload weights display maximum weight.

ACCESSORIES & OPTIONS

- AGM Batteries (825 CCA x 2)
- Air Suspension
- Aluminum Wheels
- Back-Up Alarm
- Chrome Grille
- Emergency Engine Shutdown System
- Engine Idle Shutdown (3 or 5 minutes)
- Engine Block and Oil Pan Heater with Receptacle
- Fire Extinguisher and Reflector Kit
- Front Fascia Protector
- High-Visibility Seatbelts
- Keyless Entry
- LED Lighting Package (Marker Lights)
- Low-Pro Tires
- Mobileye®
- Heated Mirrors
 - Heated Mirrors with remote adjusting (flat only)
- PTO Switches
- Touchscreen Audio System with Backup Camera
- Seat Covers
- Spare Keys (2 additional keys)
- Speed Limiting to 58, 65, 68 or 70 mph
- 102-in. Side Mirror Bracket



Keyless Entry



Air Suspension



Aluminum Wheels

NEW VEHICLE LIMITED WARRANTY

Warranty Limitations: Time or Mileage, Whichever Comes First

New Truck Warranty	Time in Years	Vehicle Miles
Basic	3	Unlimited
Engine - Cummins*	3	Unlimited
Transmission - Allison**	3	Unlimited
Drive Axle Driveshaft Front Axle I-Beam Crossmembers Flywheel Housing	3	Unlimited
Frame Rails	3 5 [†]	Unlimited Unlimited [†]
Corrosion (Rust Through)	4	Unlimited
Roadside Assistance	3 5 ^{††}	Unlimited 100,000 ^{††}
Emission Warranty	Time in Years	Vehicle Miles
Federal Emission / Defect ^{†††}	5	100,000
CARB Emission / Defect ^{†††}	5	150,000
GHG Emission	5	100,000
Tire	2	24,000

*The Cummins engine is warranted separately by Cummins.

**The Allison automatic transmission is warranted separately by Allison Transmission.

[†]After 3 years, coverage is 50% labor and parts for up to 5 years.

^{††}Tows related to emissions issues may be covered for up to 5 years or 100,000 miles (whichever comes first).

^{†††}Emission components are covered by either Isuzu or Cummins; see your Isuzu dealer for details.

The warranty coverages are determined by the mileage of the vehicle and the number of years from the delivery date. The warranty coverages are limited by whichever occurs first. See your authorized Isuzu dealer for warranty details.



RELIABLE. PREDICTABLE. TRUSTWORTHY.

QUALITY PROGRAMS



Call (866) 441-9659 – 24/7/365 – It is as simple as that when you're in need. Roadside Assistance is standard on all new Isuzu trucks. It covers tows, jump starts, lock outs, and fueling (owner is responsible for cost of fuel). Please see an authorized Isuzu dealer for details.



Specifically designed replacement parts developed for Isuzu trucks are approved for all warranty repairs and carry a one-year/unlimited-mile warranty. See your Isuzu dealer for warranty details.



Preventive maintenance increases your operating efficiency and maximizes your fuel economy. This comprehensive program protects you against increasing labor and parts costs for up to five years. PSMP also guarantees you "Priority" treatment during your service visits and when roadside assistance is needed.



Isuzu FleetValue Parts are priced to compete with aftermarket parts—but have been engineered to meet Isuzu's stringent specifications and exacting standards for quality, performance, safety, and reliability. And they carry a one-year, unlimited-mile warranty.



Isuzu Finance of America offers exclusive programs, like the Isuzu iLease, through authorized Isuzu dealers nationwide. The iLease is by far the most cost-effective option for qualifying customers, allowing them to take advantage of low monthly payments. Ask your Isuzu dealer for more information on Isuzu Finance offerings that will best fit your business needs!



***ISUZU HAS BEEN THE
BEST-SELLING LOW CAB
FORWARD TRUCK IN
AMERICA EVERY YEAR
SINCE 1986.***