

INTRODUCING THE NEW 2006

# RAIDER



MITSUBISHI  
MOTORS

Driven to Thrill



**RUGGED INDIVIDUALIST** Are you the type of person who tackles a challenge head on? Who loves getting their hands dirty? Who isn't afraid to be noticed? Then the all-new 2006 Mitsubishi Raider is the truck for you. Because the Raider is the midsize truck that's about getting things done—hauling, loading, towing—and standing out from the crowd while doing it. You'll recognize it the second you lay eyes on one. You'll see its aggressive stance, its athletic styling, its spacious bed and its huge dirt-pounding tires. It's enough to make any driver feel like they could eat nails for breakfast. And come back for seconds.

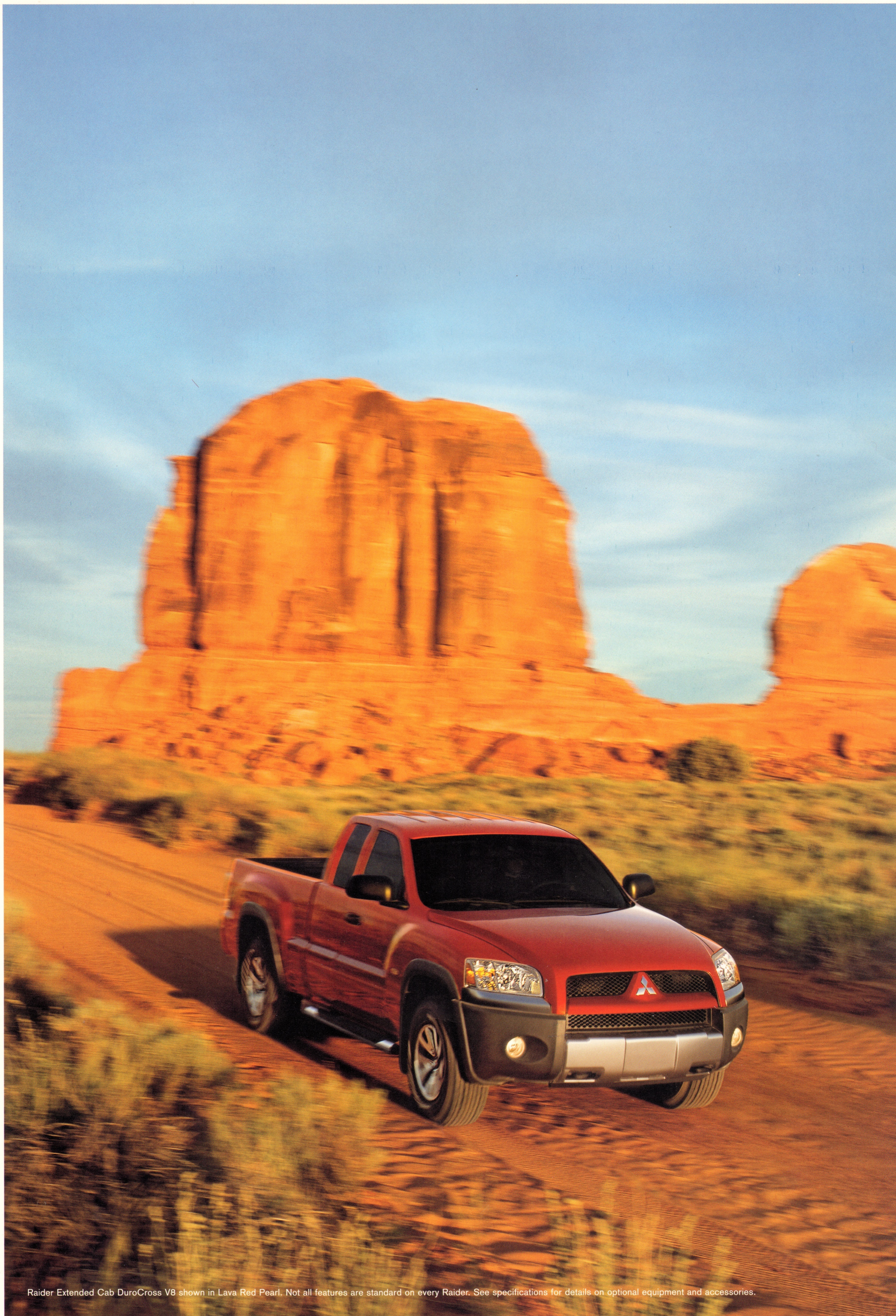

Raider Extended Cab DuroCross V8 shown in Lava Red Pearl. Not all features are standard on every Raider. See specifications for details on optional equipment and accessories.



Raider Extended Cab DuroCross V8 shown in Lava Red Pearl. Not all features are standard on every Raider. See specifications for details on optional equipment and accessories.









4.7-LITER  
**V8**

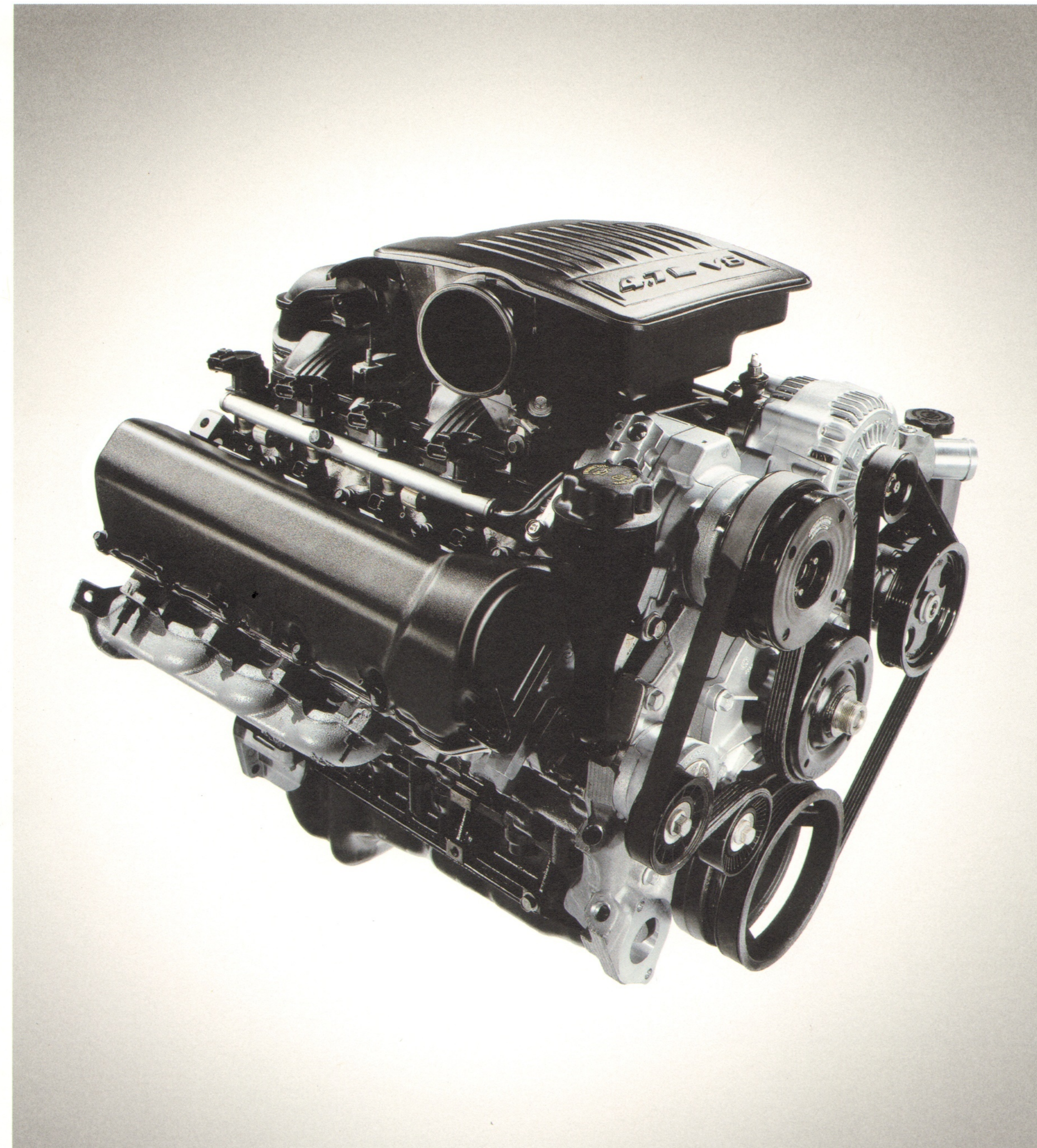

REFINED. IN A MUD-WRESTLING SORT OF WAY. There's absolutely nothing subtle about it. The 2006 Mitsubishi Raider is powered by an available massive 4.7-liter V8 that delivers 230 horsepower. It's fed by a 16-valve multi-point fuel-injection system and features a cast-iron engine block with aluminum heads. Equally imposing is the powerful 3.7-liter, SOHC V6, which churns out 210 horsepower and 235 lb-ft of torque through your choice of a 4-speed automatic or a 6-speed manual transmission. What does all this power get you? Stares from drivers of lesser trucks.

**290**

POUND-FEET OF TORQUE\*



TRAVEL LIGHT. PACK HEAVY. Now you're really going places. Not to mention taking lots of gear with you. Especially with the Raider's impressive 290 lb-ft of torque\*, which is driven through a 5-speed automatic transmission. That's pulling power you can really use. Power you'll need when your bed's full of lumber, tools, bricks, concrete, bags of rusty nails—maybe even a pair of brand-new dirt bikes. C'mon, what's the point of working hard if you can't have a little fun every once in a while?

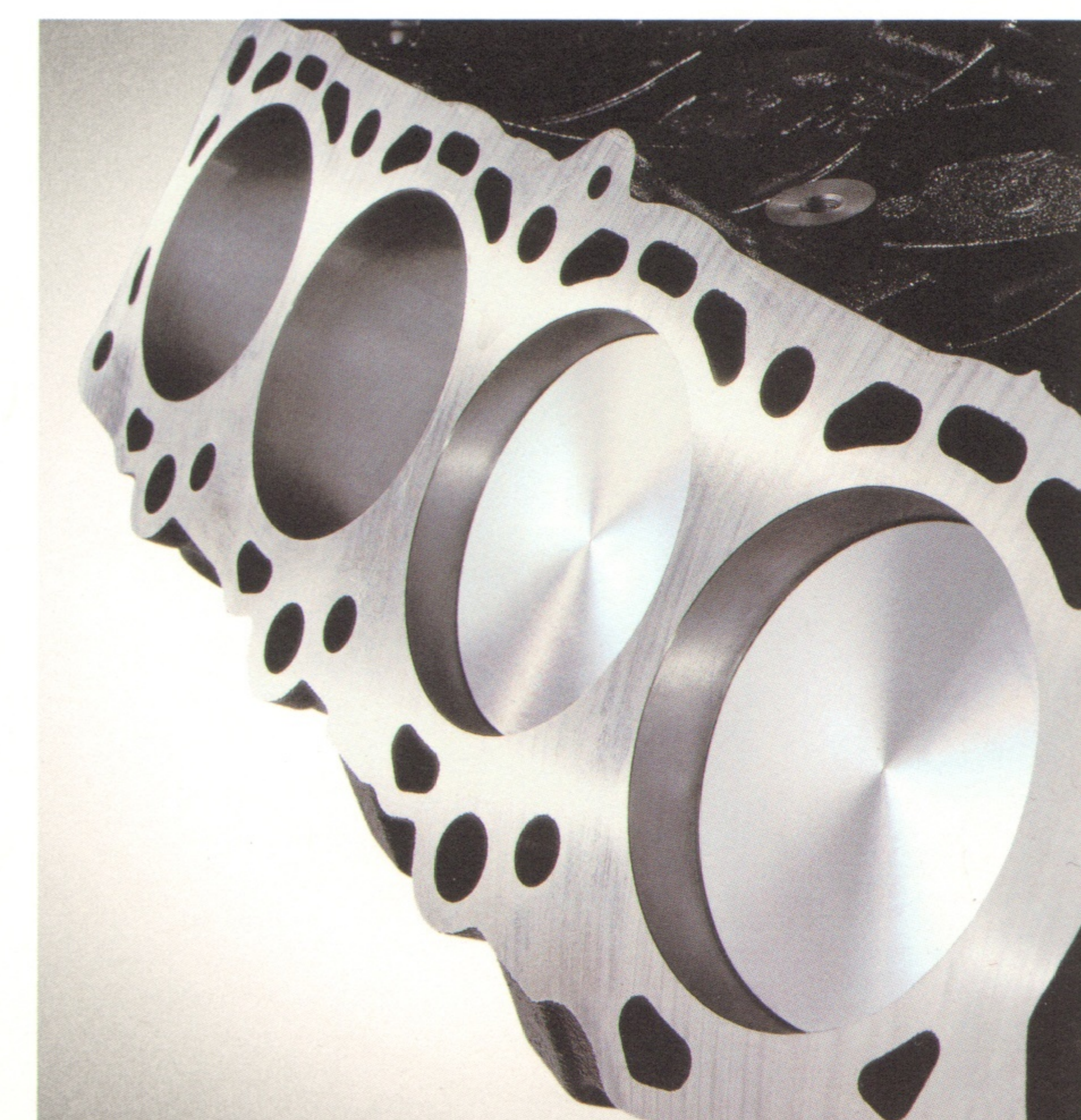

Raider Extended Cab DuroCross V8 shown in Alloy Silver Metallic.

\*V8 engine only. Not all features are standard on every Raider. See specifications for details on optional equipment and accessories.



# 6500 LB TOWING CAPACITY\*



HAULS UP TO 1700 POUNDS. That's a lot of English money, but it's even more impressive in good ol' American pounds. And it's all thanks to a fully boxed frame that utilizes hydroformed technology for more strength, stiffness and durability. Kudos also go out to the standard front and rear stabilizer bars, which help reduce body roll under heavier than normal conditions. Just be prepared for friends stopping by "because they were in the neighborhood" to borrow your new Raider.

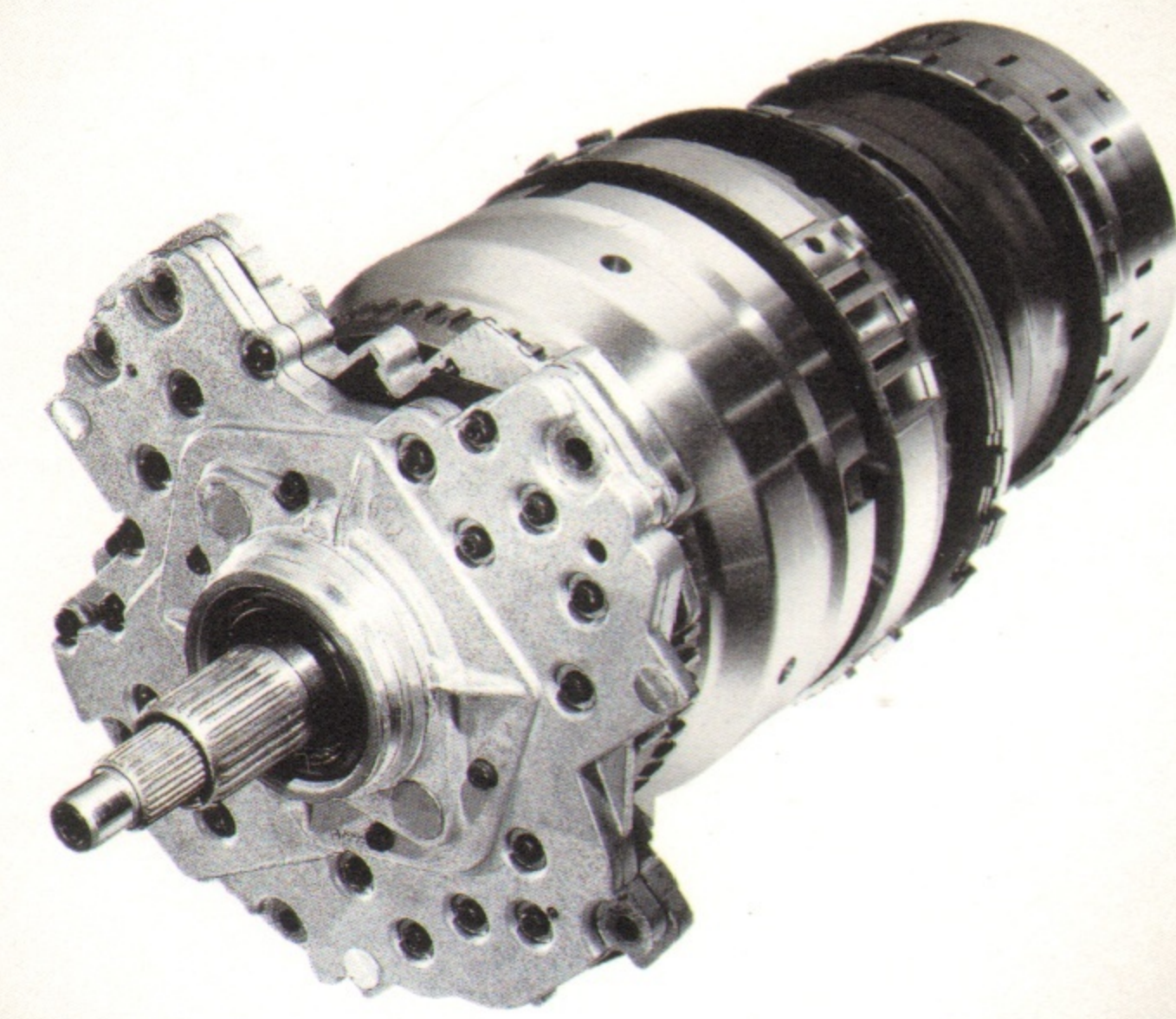

## 1700 LB MAX LARGEST PAYLOAD IN ITS CLASS†



**2WD**  
**2WD**  
**4WD**  
**AWD**

MAN CANNOT LIVE ON ASPHALT ALONE. He also needs dirt, mud, gravel and two pizzas for the price of one. That's why the U.S.-built Raider offers a choice of drivetrains: 2WD, 2WD/Part-time 4WD or Full-time 4WD (commonly known as AWD), so you can choose exactly what you need to get the most out of your new Raider. It's also why Raider sits on a heavy-duty suspension—with coil springs and gas-charged shocks up front to help make steering more precise, and a live-axle, multi-leaf arrangement at the rear to increase traction. Power rack-and-pinion steering and front and rear stabilizer bars also pitch in to improve handling. And no matter which drivetrain you choose, ride height is virtually identical, so you always enjoy a commanding view of the road ahead. So sit high, live large and, if the mood hits, head for the hills.



\*Double Cab 2WD XLS V8. †All advantage claims are supported by AIC AutoSite manufacturer-reported data for the import category of Midsize Pickup Trucks as of June 2005. Category of Midsize Pickup Trucks defined by JATO Dynamics.



Raider Extended Cab DuroCross V8 shown in Alloy Silver Metallic. Not all features are standard on every Raider. See specifications for details on optional equipment and accessories.









# 6

## PERSON SEATING

BE HARD ON YOUR TRUCK. NOT YOURSELF. Even you have a soft side. That's why you can appreciate the fully loaded interior of the Raider. Let's start with the only available six-person seating in its class\* and the added versatility of flip-up rear seats for extra storage. Then consider the available 508-watt\*, 6-CD, MP3-compatible High Output audio system with 7 Alpine® speakers. You can also couple it to an available 2.45 GHz Bluetooth™ interface so you can talk hands-free on your Bluetooth-enabled phone without a headset. In addition, the Double Cab has 102.3 cubic feet of space and class-leading legroom† to keep even the biggest guys in your crew comfortable. Now if all this doesn't bring a tear to your eye, we don't know what will.

\*Among all midsize, double-cab import trucks. AIC AutoSite manufacturer-reported data as of June 2005. †508-watt system available on Extended Cab DuroCross only.

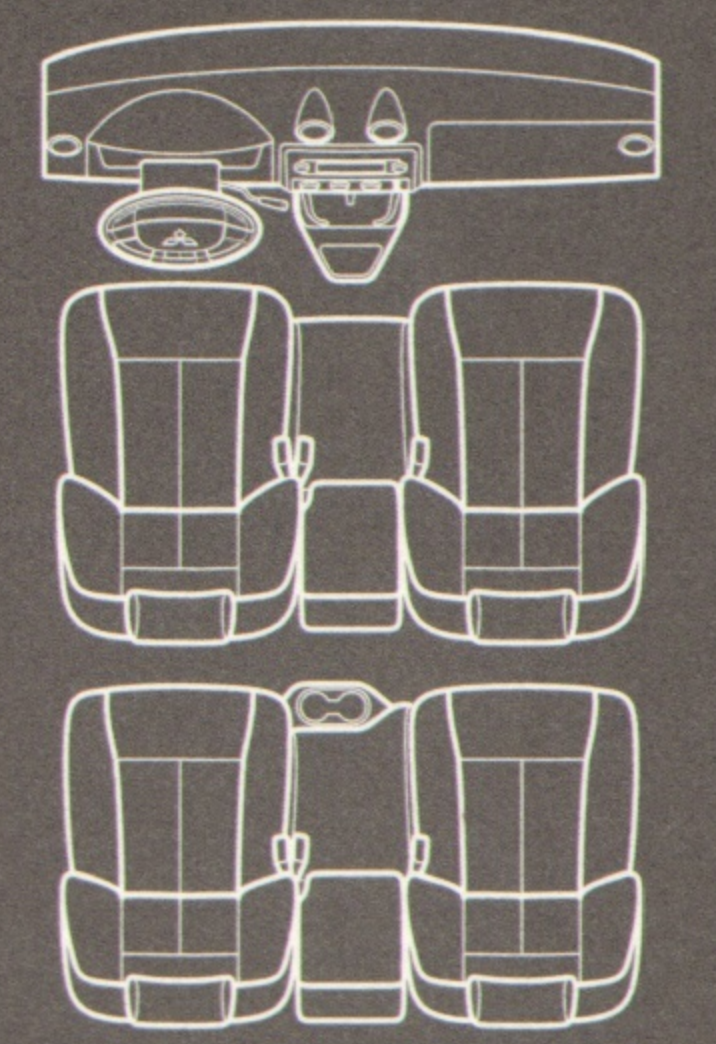

Extended Cab



Double Cab



Raider Double Cab XLS with 5-person seating shown in Khaki leather.

**508**  
WATTS

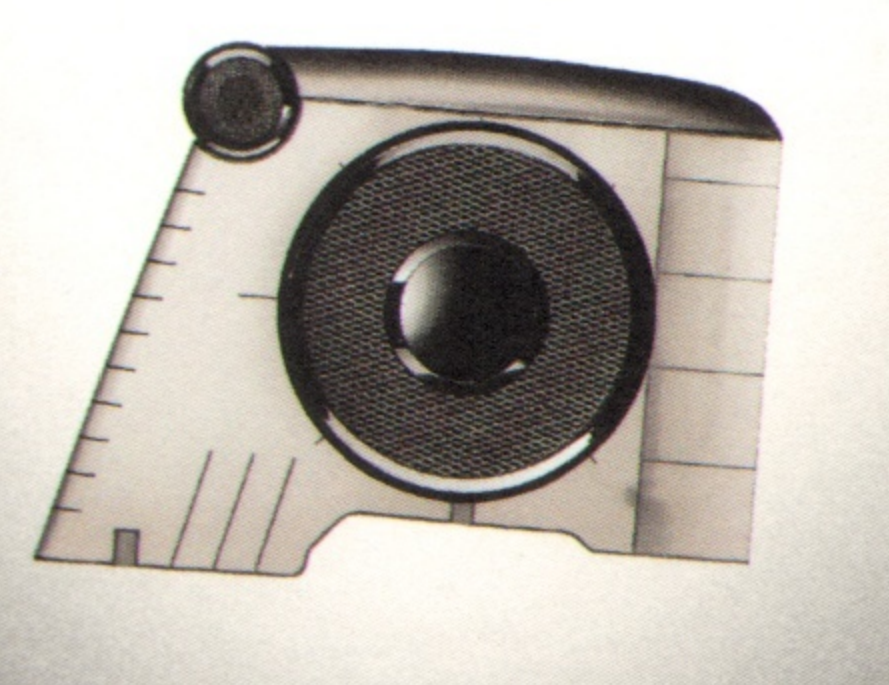

**MP3**  
COMPATIBLE



Just imagine more than 120 channels of digital quality satellite radio, including 100% commercial-free music, and over 55 channels of sports, news, talk, entertainment – even traffic and weather updated every four minutes. SIRIUS also broadcasts live play-by-play games of the NFL, NHL and NBA, and is the Official Satellite Radio partner of the NFL. You may never want to leave your Raider again.

©2005 SIRIUS Satellite Radio Inc. "SIRIUS," the SIRIUS dog logo and channel names and logos are trademarks of SIRIUS Satellite Radio, Inc. "NFL" is a registered trademark of the National Football League. "NHL" is a registered trademark of the National Hockey League. "NBA" is a registered trademark of NBA Properties, Inc. All other trademarks, service marks and logos are the property of their respective owners. All rights reserved.

**120+**  
CHANNELS

**2.45GHz** BLUETOOTH

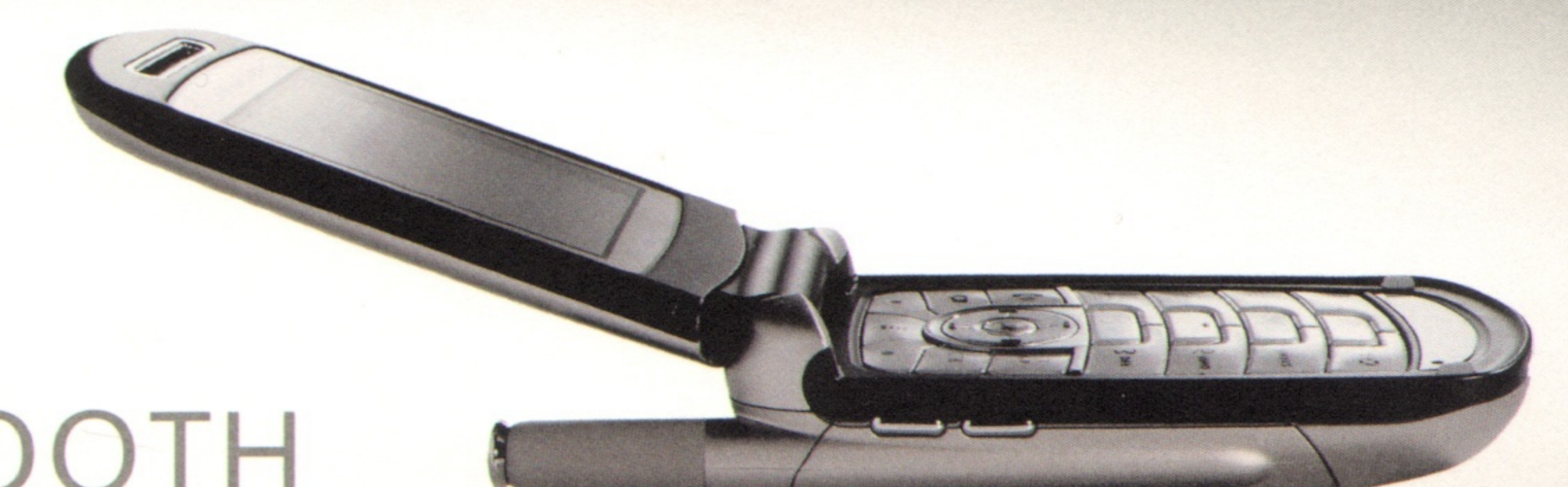

Not all features are standard on every Raider. See specifications for details on optional equipment and accessories.

Raider Double Cab XLS interior shown in Khaki leather.



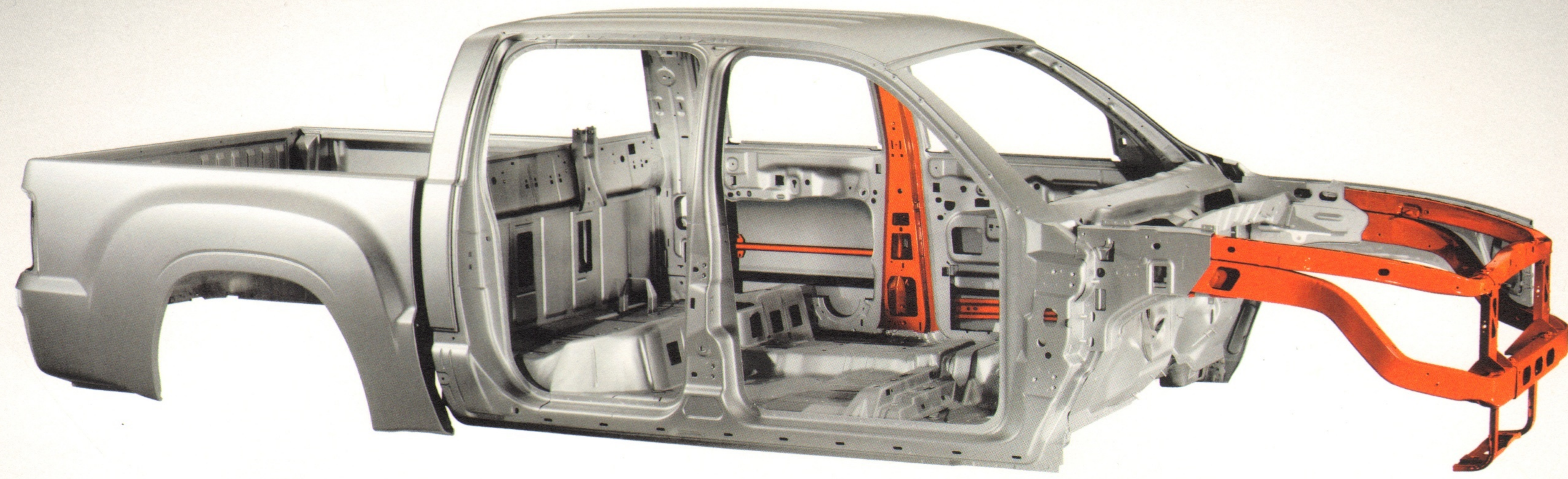

7

CROSSMEMBERS

MEET YOUR NEW BODYGUARDS, BRAINS AND BRAWN. We went to great lengths to ensure the new Raider is as safe as it is capable. We started by welding seven steel cross members in the frame for extra rigidity. Then we created octagonal front frame-rail tips that collapse rearward to help absorb impact energy in the event of a front-impact collision.

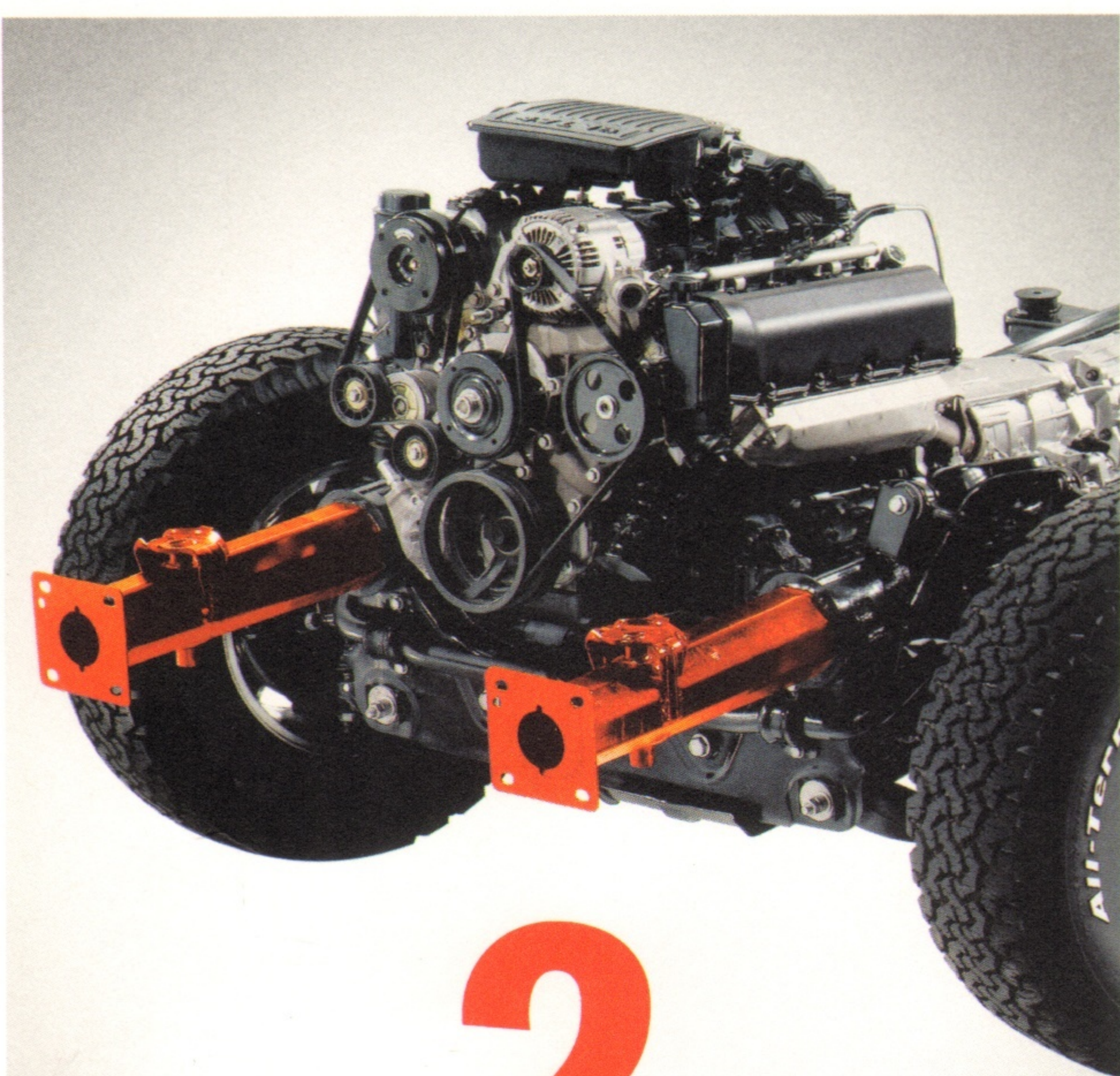

2

OCTAGONAL FRONT  
FRAME-RAIL TIPS



4

AIR BAGS\*

SAFETY AND SECURITY BOTH CALL SHOTGUN. The Raider comes equipped with Multi-Stage air bags<sup>1</sup> for both the driver and front passenger. They're linked to an Occupant Classification System that determines whether or not to deploy the air bags and how forceful the deployment should be in the event of a collision. Large front disc brakes, standard rear wheel anti-lock brakes and available four-wheel anti-lock brakes help keep Raider in control even in extreme braking conditions. Available side-curtain air bags complete your protection package as do three-point seat belts in the rear seats. Security features include user-programmable door locks that give you the option to lock the doors automatically at 15 mph, or keep them unlocked.

\*Shown with available side-curtain air bags. <sup>1</sup>Air bags can cause serious injury or death to anyone too close to an air bag when it deploys. To decrease the risk of injury from a deploying air bag, all occupants must be properly restrained and seated well back, upright and in the middle of the seat. Do not lean against the door. Always place children 12 and under in the rear seat and use appropriate child restraints. Never place a rear-facing infant restraint in the front seat. See your Owner's Manual and instructions provided with your child restraint for more information.

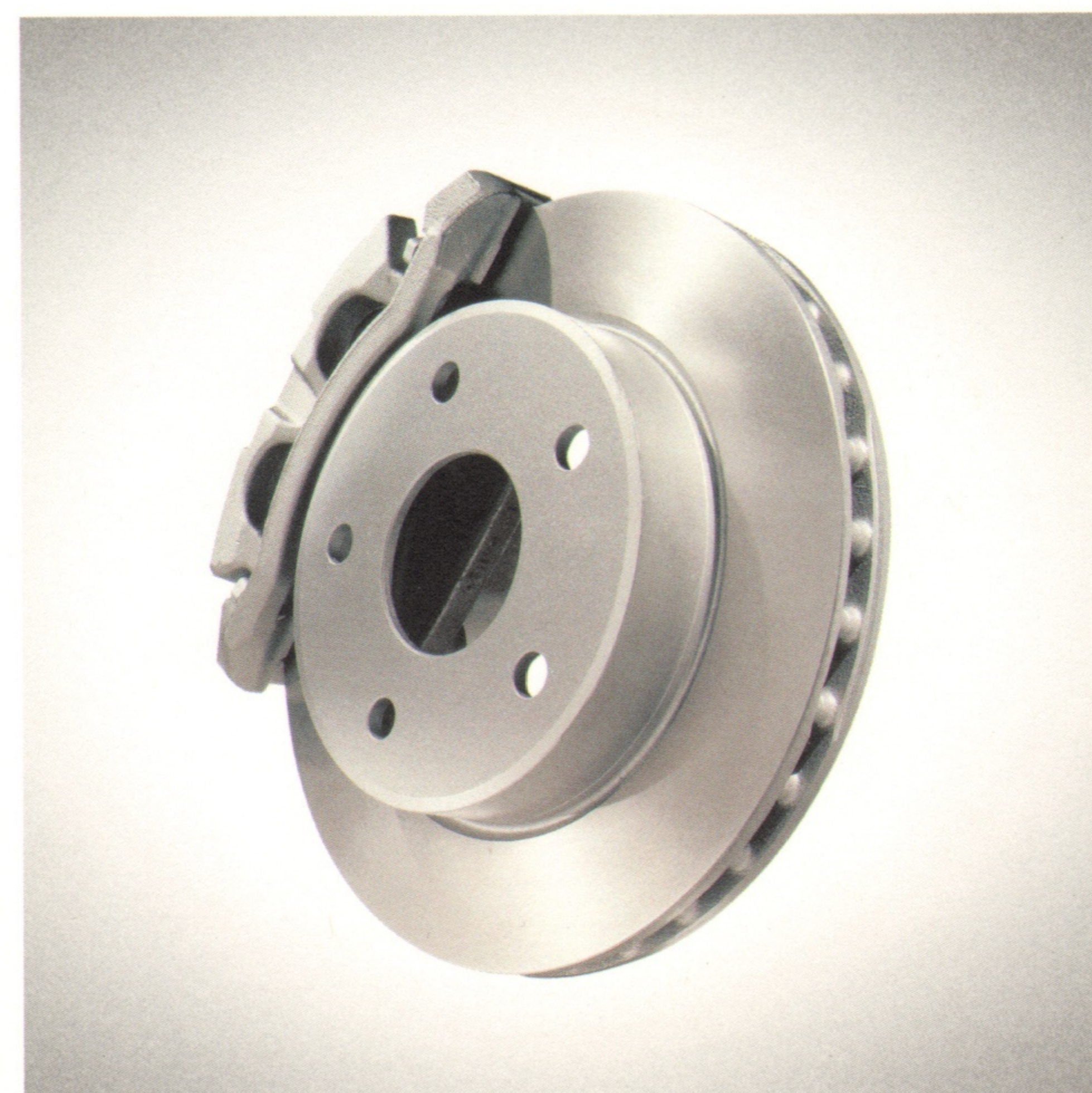





Raider Extended Cab DuroCross V8 shown in Alloy Silver Metallic. Not all features are standard on every Raider. See specifications for details on optional equipment and accessories.









Extended Cab LS  
Extended Cab DuroCross (shown)



Double Cab LS  
Double Cab DuroCross  
DuroCross XLS (shown)

## EXTERIOR & INTERIOR COLORS



Steel Blue Pearl  
(LS)

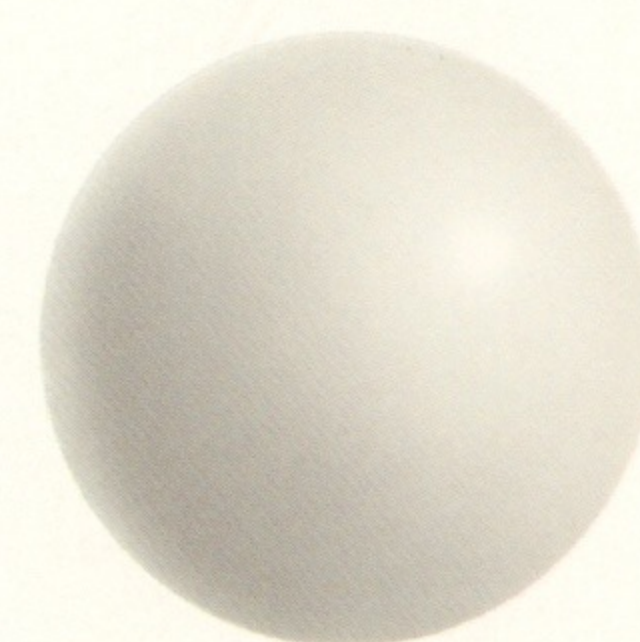

Arctic White  
(LS, DuroCross)

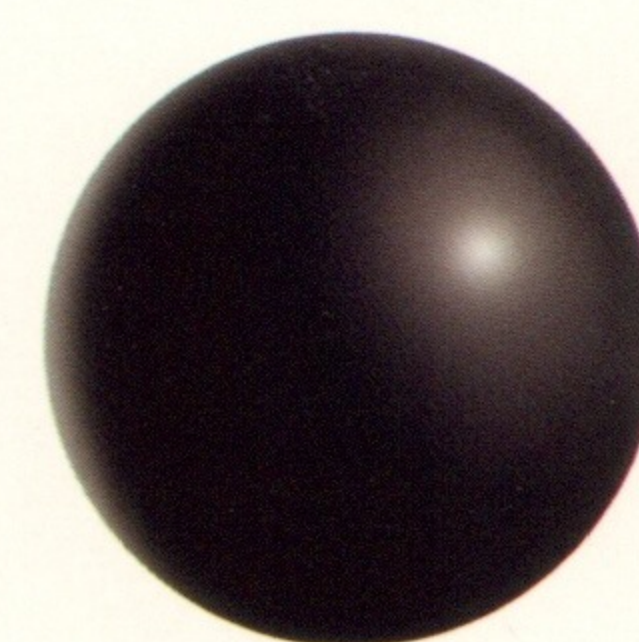

Carbide Black  
(All)



Alloy Silver Metallic  
(All)



Lava Red Pearl  
(All)



Sahara Sand Metallic  
(DuroCross, XLS)

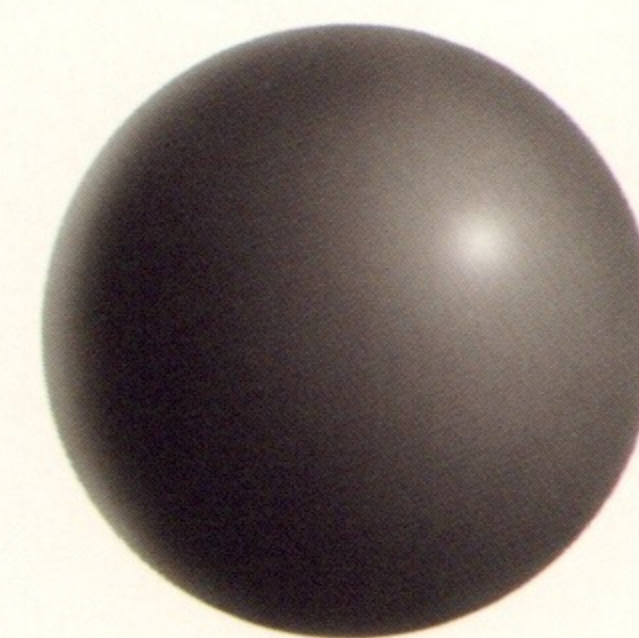

Granite Gray Metallic  
(All)



Cobalt Blue Pearl  
(DuroCross, XLS)



Slate Fabric  
(LS, DuroCross)



Khaki Fabric  
(DuroCross)



Slate Leather  
(XLS)



Khaki Leather  
(XLS)

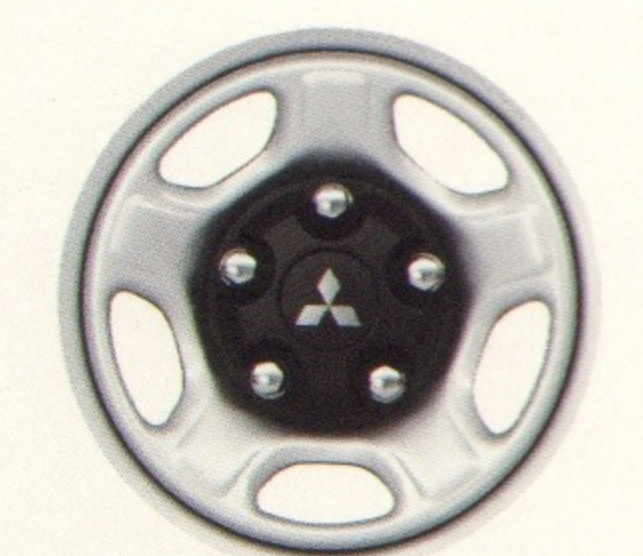

16" Steel Wheel  
(Extended Cab LS)

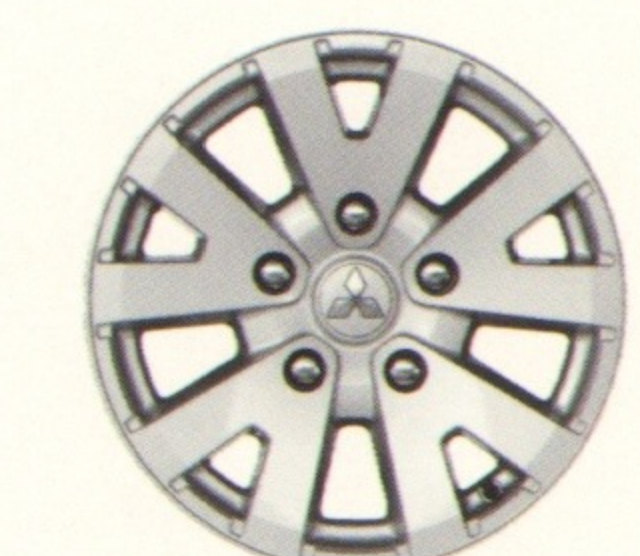

16" Alloy Wheel  
(DuroCross V6, Double Cab LS)



16" Machine-Finished Alloy Wheel  
(DuroCross V8)

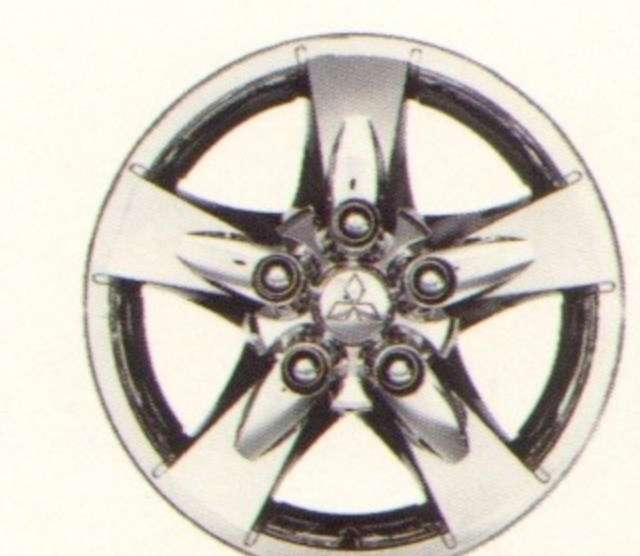

17" ChromeClad Alloy Wheel  
(XLS)

The 2006 Mitsubishi Raider is covered by the same 5-year/60,000-mile Bumper-to-Bumper New Vehicle Limited Warranty as all our other vehicles. That's the most comprehensive limited-warranty term offered for Midsize Pickup Trucks sold in the U.S. It is augmented by a 7-year/100,000-mile Anti-Corrosion/Perforation Limited Warranty and by our 5-year/Unlimited-mile Roadside Assistance program.

Raider's class-leading warranty is just one more indication of how confident we are in the quality, reliability and dependability of our vehicles.

\*Based on OEM-supplied warranty information for 2005 and 2006 model-year Midsize Pickup Trucks (category defined by JATO Dynamics) sold in the U.S.

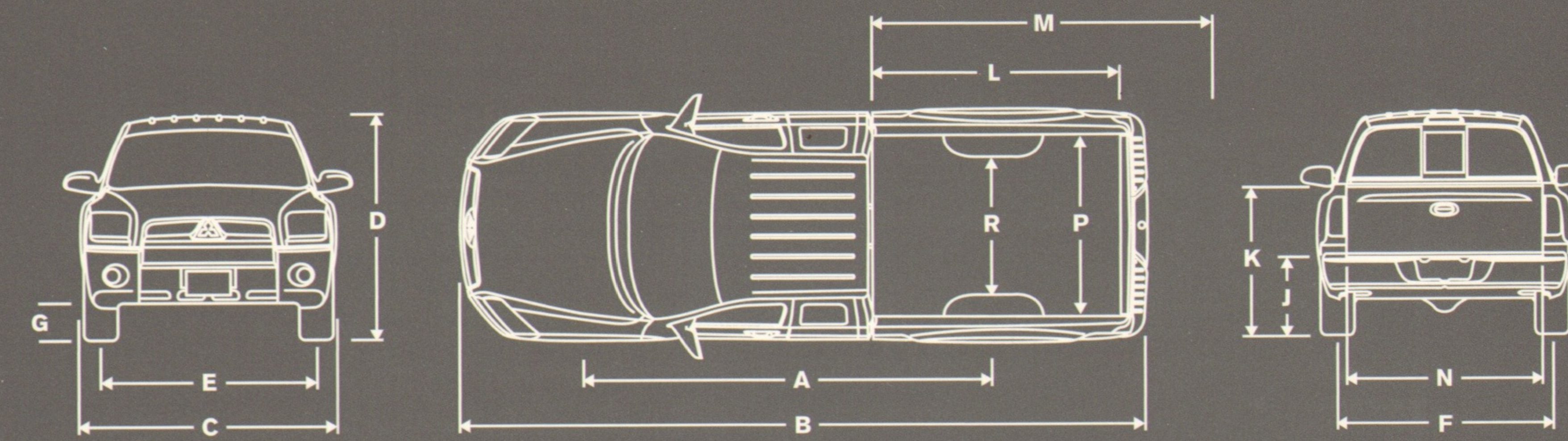

## RAIDER EXTENDED CAB

### DRIVE LINE AND ENGINES

	LS	DUROCROSS	4WD DUROCROSS
3.7L SOHC V6 (90°)	•	•	•
Torque:	235 lb-ft @ 3600 rpm		
Power:	210 hp (SAE net) @ 5200 rpm		
Displacement:	3701 cc		
Cast iron block, aluminum alloy heads			
Counter-rotating balance shaft			
6-speed GETRAG® manual overdrive transmission	•	•	•
Ratios: 1st: 4.23, 2nd: 2.53, 3rd: 1.67, 4th: 1.23, 5th: 1.00, 6th: 0.79			
4-speed automatic transmission	•	•	•
Ratios: 1st: 2.84, 2nd: 1.57, 3rd: 1.00, 4th: 0.69			

### 4.7L SOHC V8 (90°)

	LS	DUROCROSS	4WD DUROCROSS
Torque:	290 lb-ft @ 3600 rpm		
Power:	230 hp (SAE net) @ 4600 rpm		
Displacement:	4701 cc		
Cast iron block, aluminum alloy heads			
5-speed automatic transmission	•	•	•
Ratios: 1st: 3.00; 2nd (upshift): 1.67, (kick-down): 1.50; 3rd: 1.00; 4th: 0.75; 5th: 0.67			
Part-time 4-wheel drive with 2-speed transfer case	•	•	•
Limited-slip rear differential	•	V8	•

### FRAME AND CHASSIS

	LS	DUROCROSS	4WD DUROCROSS
Body-on-ladder-frame construction	•	•	•
Power rack-and-pinion steering	•	•	•
Front vented disc brakes (312mm dia.)	•	•	•
Rear anti-lock drum brakes	•	•	•
Four-wheel ABS	•	•	•
Independent front suspension	•	•	•
Forged-steel upper A-arm, cast-iron lower A-arm	•	•	•
Coil springs over gas-charged shock absorbers	•	•	•
Link-type stabilizer bar	•	•	•
Live-axle rear suspension (Hotchkiss geometry)	•	•	•
Multi-leaf 2-stage longitudinal springs	•	•	•
Fore-and-aft staggered gas-charged shock absorbers	•	•	•
Link-type stabilizer bar	•	•	•
16" x 7" drop-center steel wheels	•	•	•
P245/70 BSW tires	•	•	•
16" x 8" alloy wheels	•	•	•
P265/70 OWL all-terrain tires	•	•	•
LT265/70 OWL all-terrain tires (BFGoodrich)	•	•	•
Full-size spare wheel and tire	•	•	•
Tow hooks	•	•	•
Skid plates (front suspension, fuel tank, tow hooks)	•	•	•
DuroCross-tuned Heavy-Duty shocks	•	•	•
Heavy-Duty service components:	•	•	•
750 A battery; transmission cooler; power-steering cooler	•	•	•
3.92 rear axle ratio	•	V8	V8
3.55 rear axle ratio	PKG	•	•
3.21 rear axle ratio	•	•	•
Trailer hitch with 2" sq. receiver and 7-pin wiring harness <sup>2</sup>	ACC	V8	V8

### EXTERIOR

	LS	DUROCROSS	4WD DUROCROSS
Fog lights	•	•	•
5" x 7" power sideview mirrors	PKG	•	•
8" x 9" folding, heated power sideview mirrors	•	•	•
Bedliner	PKG/ACC	•	•
Cargo-bed tiedowns	•	•	•
Fender flares	ACC	•	•
Front and rear mudguards	PKG/ACC	•	•
Tubular side-steps	ACC	•	•
Polished stainless-steel exhaust pipe finisher	ACC	•	•
Door-sill scuff plate	ACC	•	•
Tinted glass	•	•	•
Rear privacy glass	•	•	•
Sliding rear-center window	•	•	•
Dark-gray composite front bumper fascia	•	•	•
Front center bright skid-plate fascia	•	•	•
Steel full-width rear bumper	•	•	•

### COMFORT AND CONVENIENCE

	LS	DUROCROSS	4WD DUROCROSS
Air conditioning	•	•	•
Power windows	PKG	•	•
Power door locks	PKG	•	•
Keyless entry	PKG	•	•
Height-adjustable steering column	PKG	•	•
Cruise control	PKG	•	•
AM/FM 4-speaker CD audio system	•	•	•
Auxiliary output jack for personal audio device	•	•	•
508W High Output audio system with Alpine® speakers	•	PKG	PKG
6-CD, MP-3 compatible, steering wheel-mounted audio controls; SIRIUS® satellite radio, enclosed subwoofer	•	•	•
Bluetooth™ hands-free telephone interface	•	V8	V8
Front 40/20/40 seats for 3 occupants with armrest up	•	•	•
Front bucket seats with multi-purpose center floor console	•	PKG	PKG
40/40 rear seating with fold-up seat cushions	PKG	•	•
Auto-dimming rearview mirror	•	V8	V8
Standard maximum seating capacity, front/rear	3/0	3/2	3/2
Passenger-side visor mirror	•	•	•

### SAFETY AND SECURITY

	LS	DUROCROSS	4WD DUROCROSS
3-point safety belts	•	•	•
Outboard for front, incl. pre-tensioners	•	•	•
All seating positions for rear	•	•	•
Height-adjustable front shoulder-belt mounts	•	•	•
Front outboard multi-stage air bags <sup>1</sup>	•	•	•
Passenger-side Occupant Classification System	•	•	•
Driver's seat-rail position sensors	•	•	•
Front-passenger air bag cutoff switch	•	•	•
Lower and upper anchors for child-seat installation	•	•	•
Key with integrated door lock/unlock transmitter and panic feature	•	•	•
Front crumple zones with collapsible front frame ends	•	•	•

### EXTERIOR DIMENSIONS (INCHES)

A Wheelbase	131.3
B Overall length, excl. trailer hitch	219.9
C Overall width	71.9
D Overall height	68.6
E Track, front	62.8
F Track, rear	62.9
G Ground clearance, front	7.9
H Ground clearance, rear	8.1
J Cargo-floor height	31.9
K Cargo-bed liftover height (top of rail)	49.5
L Cargo-bed length, tailgate closed	78.8
M Cargo-bed length, tailgate open	100.3
N Tailgate opening width	53.3
P Cargo-bed width at floor, wall-to-wall	59.6
R Cargo-bed width at floor, between wheel wells	45.2

### INTERIOR DIMENSIONS AND CAPACITIES

Headroom (in., front/rear)	39.6/36.5	
Legroom (in., front/rear)	41.9/32.1	
Shoulder room (in., front/rear)	57.7/57.4	
Hip room (in., front/rear)	54.9/56.9	
Interior room (cu. ft., front/rear)	55.3/39.0	
Cabin cargo volume (rear seat up) (cu. ft.)	30.0	
Turning radius (ft., curb-to-curb)	22	
GWWR (lb.)	6010	
Fuel tank capacity (gal. Regular Unleaded)	22	
Estimated fuel use (mpg, city/highway) <sup>2</sup>		
V6 manual	16/22	n/a
V6 auto	16/22	15/19
V8 auto	15/20	15/20

### OPTIONAL EQUIPMENT PACKAGES FOR RAIDER EXTENDED CAB MODELS

#### POWER & CONVENIENCE PACKAGE FOR LS

- Power windows
- Power door locks + keyless entry
- Power sideview mirrors (5" x 7")
- 40/40 rear seating
- Height-adjustable steering wheel
- Cruise control
- Floor mats

#### HIGH OUTPUT SOUND PACKAGE FOR DUROCROSS

- 508W 6-CD/MP3 audio system with 7 Alpine speakers
- Steering wheel-mounted audio controls
- Enclosed subwoofer
- SIRIUS® satellite radio with 6-months prepaid subscription
- Front bucket seats with floor console

#### PREMIUM PACKAGE FOR DUROCROSS V8

- Bright interior accents
- Auto-dimming rearview mirror
- Bluetooth hands-free telephone interface
- 16" x 8" machine-finished alloy wheels

#### HD TOW PACKAGE FOR DUROCROSS

- Class IV trailer hitch and receiver
- 7-pin wiring harness with 4-pin adaptor
- Limited-slip differential (std. for 4WD DuroCross)
- 3.92 rear axle ratio (std. for 4WD DuroCross)

#### PREFERRED EQUIPMENT PACKAGE FOR DUROCROSS

- Cargo bed extender
- Cargo bed rail protectors
- Side-window air deflectors
- Wheel locks (5 wheels)

#### PROTECTION PACKAGE FOR DUROCROSS

- Cargo bed rail protector
- Hood protector
- Wheel locks (5 wheels)
- All-weather floor mats (Regional availability)

#### PROTECTION PACKAGE FOR LS

- Cargo bed liner
- Cargo bed rail protector
- Tailgate cover
- Hood protector
- Mud guards, front and rear
- Wheel locks (5 wheels)
- All-weather floor mats (Regional availability)

#### CARGO BED GEAR PACKAGE FOR LS

- Cargo bed liner
- Cargo bed rail protectors
- Tailgate cover
- Cargo bed extender
- Wheel locks (5 wheels)

LEGEND	
•	Standard equipment
•	Not available
PKG	Item is available, at additional cost, as a factory-installed package.
ACC	Item is available, at additional cost, as a Retailer-installed accessory.

For complete details about equipment configuration and Mitsubishi Genuine Accessories, please consult your Mitsubishi Retailer.



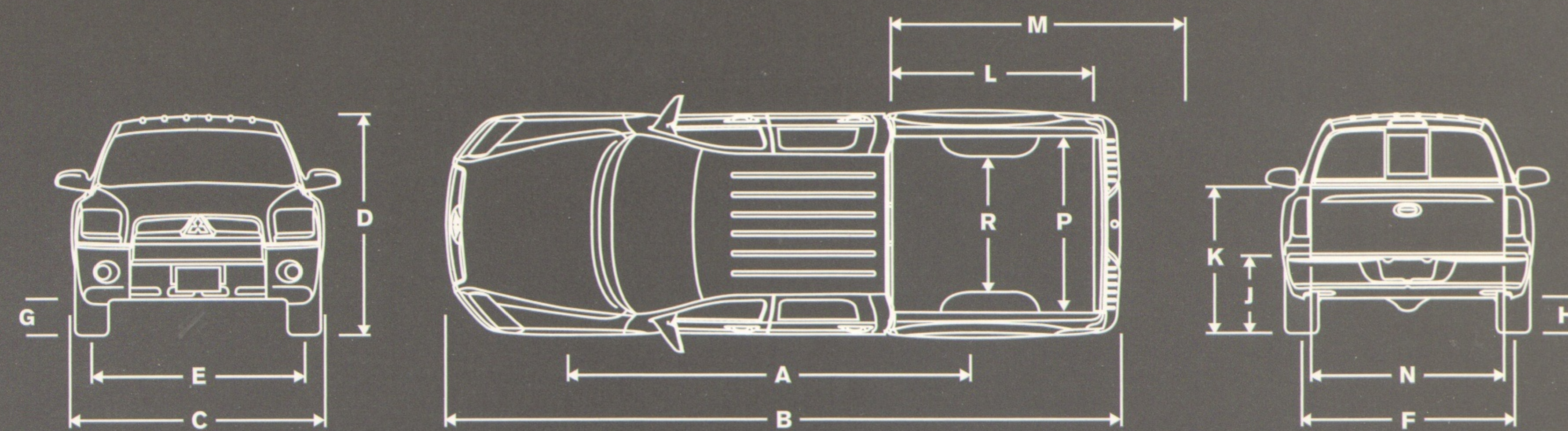

## RAIDER DOUBLE CAB

### DRIVE LINE AND ENGINES

	2WD		4WD	
	LS	DUROCROSS XLS	LS	DUROCROSS XLS
3.7L SOHC V6 (90°)	•	•	•	•
Torque:	235 lb-ft @ 3600 rpm			
Power:	210 hp (SAE net) @ 5200 rpm			
Displacement:	3701 cc			
Cast iron block, aluminum alloy heads				
Counter-rotating balance shaft				
4-speed automatic transmission	•	•	•	•
Ratios: 1st: 2.84, 2nd: 1.57, 3rd: 1.00, 4th: 0.69				

or

	2WD		4WD	
	LS	DUROCROSS XLS	LS	DUROCROSS XLS
4.7L SOHC V8 (90°)	•	•	•	•
Torque:	290 lb-ft @ 3600 rpm			
Power:	230 hp (SAE net) @ 4600 rpm			
Displacement:	4701 cc			
Cast iron block, aluminum alloy heads				
5-speed automatic transmission	•	•	•	•
Ratios: 1st: 3.00, 2nd (upshift): 1.67, (kick-down): 1.50, 3rd: 1.00, 4th: 0.75, 5th: 0.67				

Part-time 4-wheel drive with 2-speed transfer case	•	•	•	•
Full-time 4-wheel Drive	•	•	•	•
Limited-slip rear differential	•	V8	•	•

### FRAME AND CHASSIS

Body-on-ladder-frame construction	•	•	•	•
Power rack-and-pinion steering	•	•	•	•
Front vented disc brakes (312mm dia.)	•	•	•	•
Rear anti-lock drum brakes	•	•	•	•
Four-wheel ABS	•	PKG	•	PKG
Independent front suspension	•	•	•	•
Forged-steel upper A-arm, cast-iron lower A-arm	•	•	•	•
Coil springs over gas charged shock absorbers	•	•	•	•
Link-type stabilizer bar	•	•	•	•
Live-axle rear suspension (Hotchkiss geometry)	•	•	•	•
Multi-leaf 2-stage longitudinal springs	•	•	•	•
Fore-and-aft staggered gas-charged shock absorbers	•	•	•	•
Link-type stabilizer bar	•	•	•	•

16" x 8" alloy wheels	•	•	•	•
P255/65 BSW all-season tires	•	•	•	•
P265/70 OWL all-terrain tires	•	•	•	•
LT265/70 OWL all-terrain tires (BFGoodrich)	•	•	•	•
17" x 8" ChromeClad alloy wheels	•	•	•	•
265/65 BSW tires	•	•	•	•
Full-size spare wheel and tire	•	•	•	•
Tow hooks	•	•	•	•

Skid plates (front suspension, fuel tank, tow hooks)	•	•	•	•
DuroCross-tuned Heavy Duty shocks	•	•	•	•
Heavy-Duty service components:	•	•	•	•
750 A battery; transmission cooler; power steering cooler	•	•	•	•

3.92 rear axle ratio	•	V8	•	•
3.55 rear axle ratio	•	•	•	•
Trailer hitch with 2" sq. receiver and 7-pin wiring harness*	•	V6/V8	•	V6/V8

### EXTERIOR

Fog lights	•	PKG	•	PKG	•
5" x 7" power sideview mirrors	•	•	•	•	•
6" x 9" folding, heated power sideview mirrors	•	•	•	•	•
Bedliner	•	PKG/ACC	•	PKG/ACC	•
Cargo-bed tiedowns	•	•	•	•	•
Fender flares	•	ACC	•	ACC	•
Front and rear mudguards	•	PKG/ACC	•	PKG/ACC	•
Tubular side-steps	•	ACC	•	ACC	•
Polished stainless-steel exhaust pipe finisher	•	ACC	•	ACC	•
Door-sill scuff plate	•	ACC	•	ACC	•
Tinted glass	•	•	•	•	•
Rear privacy glass w/sliding tinted center rear window	•	PKG	•	PKG	•
Rear privacy glass w/defroster	•	•	•	•	•
Rear privacy glass w/solid rear window	•	•	•	•	•
Dark-gray composite front bumper corners	•	•	•	•	•
Front center bright skid-plate fascia	•	•	•	•	•
Body-colored front bumper fascia	•	•	•	•	•
Steel full-width rear bumper	•	•	•	•	•

### COMFORT AND CONVENIENCE

Air conditioning	•	•	•	•
Power windows	•	•	•	•
Power door locks	•	•	•	•
Keyless entry	•	•	•	•
Height-adjustable steering column	•	•	•	•
Cruise control	•	•	•	•
AM/FM 4-speaker CD audio system	•	•	•	•
Auxiliary output jack for personal audio device	•	•	•	•
276W 6-CD/MP3 audio system with 6 Alpine speakers, steering wheel-mounted audio controls; SIRIUS satellite radio	•	V8 PKG	•	PKG
Bluetooth hands-free telephone interface	•	V8	•	V8
Front 40/20/40 seat – for 3 occupants with armrest up	•	•	•	•
Front bucket seats with multi-purpose center floor console	•	V8 PKG	•	PKG
6-way power adjustable driver's seat	•	V8	•	V8
Leather front seating surfaces with heater controls	•	•	•	•
60/40 rear seating with fold-up seat cushions	•	•	•	•
Standard maximum seating capacity	3/3	3/3	2/3	3/3
Auto-dimming rearview mirror	•	V8	•	V8
Overhead storage console + information panel	•	•	•	•
Passenger-side visor mirror	•	•	•	•

### SAFETY AND SECURITY

3-point safety belts for all seating positions	•	•	•	•
Outboard for front, incl. pre-tensioners	•	•	•	•
All seating positions for rear	•	•	•	•
Height-adjustable front shoulder-belt mounts	•	•	•	•
Front outboard multi-stage air bags <sup>1</sup>	•	•	•	•
Passenger-side Occupant Classification System	•	•	•	•
Driver's seat-rail position sensors	•	•	•	•
Front-passenger air bag cutoff switch	•	•	•	•
Roof-mounted front and rear side-impact curtain air bags <sup>1</sup>	•	•	PKG	•
Lower and upper anchors for child-seat installation	•	•	•	•
Child safety locks (rear doors)	•	•	•	•
Key w/integrated door lock/unlock transmitter and panic feature	•	•	•	•
Front crumple zones with collapsible front frame ends	•	•	•	•

### EXTERIOR DIMENSIONS (INCHES)

A Wheelbase	131.3
B Overall length, excl. trailer hitch	219.9
C Overall width	71.9
D Overall height	69.8
E Track, front	62.9
F Track, rear	62.9
G Ground clearance, front	7.9
H Ground Clearance, rear	8.1
J Cargo-floor height	31.9
K Cargo-bed liftover height (top of rail)	49.5
L Cargo-bed length, tailgate closed	64.9
M Cargo-bed length, tailgate open	86.3
N Tailgate opening width	53.3
P Cargo-bed width at floor, wall-to-wall	59.6
R Cargo-bed width at floor, between wheel wells	45.2

### INTERIOR DIMENSIONS AND CAPACITIES

Headroom (in., front/rear)	39.9/38.4
Legroom (in., front/rear)	41.9/36.4
Shoulder room (in., front/rear)	57.7/57.5
Hip room (in., front/rear)	54.9/56.0
Interior room (cu. ft., front/rear)	55.3/46.5
Cabin cargo volume (rear seat up) (cu. ft.)	37.1
Turning radius (ft., curb-to-curb)	22
GVWR (lb.)	6010
Fuel tank capacity (gal.)	22

	2WD		4WD	
	LS	DUROCROSS XLS	LS	DUROCROSS XLS
Estimated fuel use (mpg, city/highway) <sup>2</sup>				
V6 auto	16/22	16/22	15/19	15/19
V8 auto	15/20	15/20	15/20	15/20

### OPTIONAL EQUIPMENT PACKAGES FOR RAIDER DOUBLE CAB MODELS

#### EXTERIOR APPEARANCE GROUP FOR LS

- Body-colored front bumper fascia
- Fog lights
- Sliding center-rear window (privacy glass)
- 16" alloy wheel (painted)

#### PREMIUM SOUND PACKAGE FOR DUROCROSS

- 276W 6-CD/MP3 audio system with 6 Alpine speakers
- Steering wheel-mounted audio controls
- SIRIUS satellite radio with 6-months prepaid subscription
- Front bucket seats with floor console

#### PREMIUM PACKAGE FOR DUROCROSS V8

- 6-way power-adjustable driver's seat
- Bright interior accents
- Auto-dimming rearview mirror
- Bluetooth hands-free telephone interface
- 16" x 8" machine-finished alloy wheels

#### HD TOW PACKAGE FOR DUROCROSS

- Class IV trailer hitch and receiver
- 7-pin wiring harness with 4-pin adaptor
- Limited-slip differential (std. for 4WD DuroCross)
- 3.92 rear axle ratio (std. for 4WD DuroCross)

#### SECURITY PACKAGE FOR XLS

- Roof-mounted side-impact curtain air bags<sup>1</sup>
- Security alarm
- Auto-on and auto-off headlights
- 4-wheel anti-lock braking system (ABS)
- Electronic engine immobilizer (dedicated key override)

#### PREFERRED EQUIPMENT PACKAGE FOR DUROCROSS

- Cargo bed extender
- Cargo bed rail protectors
- Side-window air deflectors
- Wheel locks (5 wheels)

#### PROTECTION PACKAGE FOR DUROCROSS

- Cargo bed rail protector
- Hood protector
- Wheel locks
- All-weather floor mats (Regional availability)

#### PROTECTION PACKAGE FOR LS AND XLS

- Cargo bed liner
- Cargo bed rail protector
- Tailgate cover
- Hood protector
- Mudguards, front and rear
- Wheel locks (5 wheels)
- All-weather floor mats (Regional availability)

#### CARGO BED GEAR PACKAGE FOR LS AND XLS

- Cargo bed liner
- Cargo bed rail protectors
- Tailgate cover
- Cargo bed extender
- Wheel locks (5 wheels)

<sup>1</sup>Air bags can cause serious injury or death to anyone too close to an air bag when it deploys. To decrease the risk of injury from a deploying air bag, all occupants must be properly restrained and seated well back, upright and in the middle of the seat. Do not lean against the door. Always place children 12 and under in the 2nd-row seat and use appropriate child restraints. Never place a rear-facing infant restraint in the front seat. See your Owner's Manual and instructions provided with your child restraint for more information. <sup>2</sup>See Owner's Manual for details, requirements and restrictions. <sup>3</sup>EPA fuel-use estimates to be used as a standardized comparison with other vehicles. Your mileage may vary depending on driving style and environmental conditions. <sup>4</sup>Late availability on 2WD V6 and 4WD V6.

## RAIDER ACCESSORIES

MAKE THE RAIDER YOUR OWN. CUSTOMIZE YOUR INTERIOR AND EXTERIOR FROM OUR WIDE ARRAY OF MITSUBISHI GENUINE ACCESSORIES.



Hood Deflector



Bed Extender



Bed Rail Protector



Door Sill Scuff Plates



Side Window Air Deflectors



Bed Liner

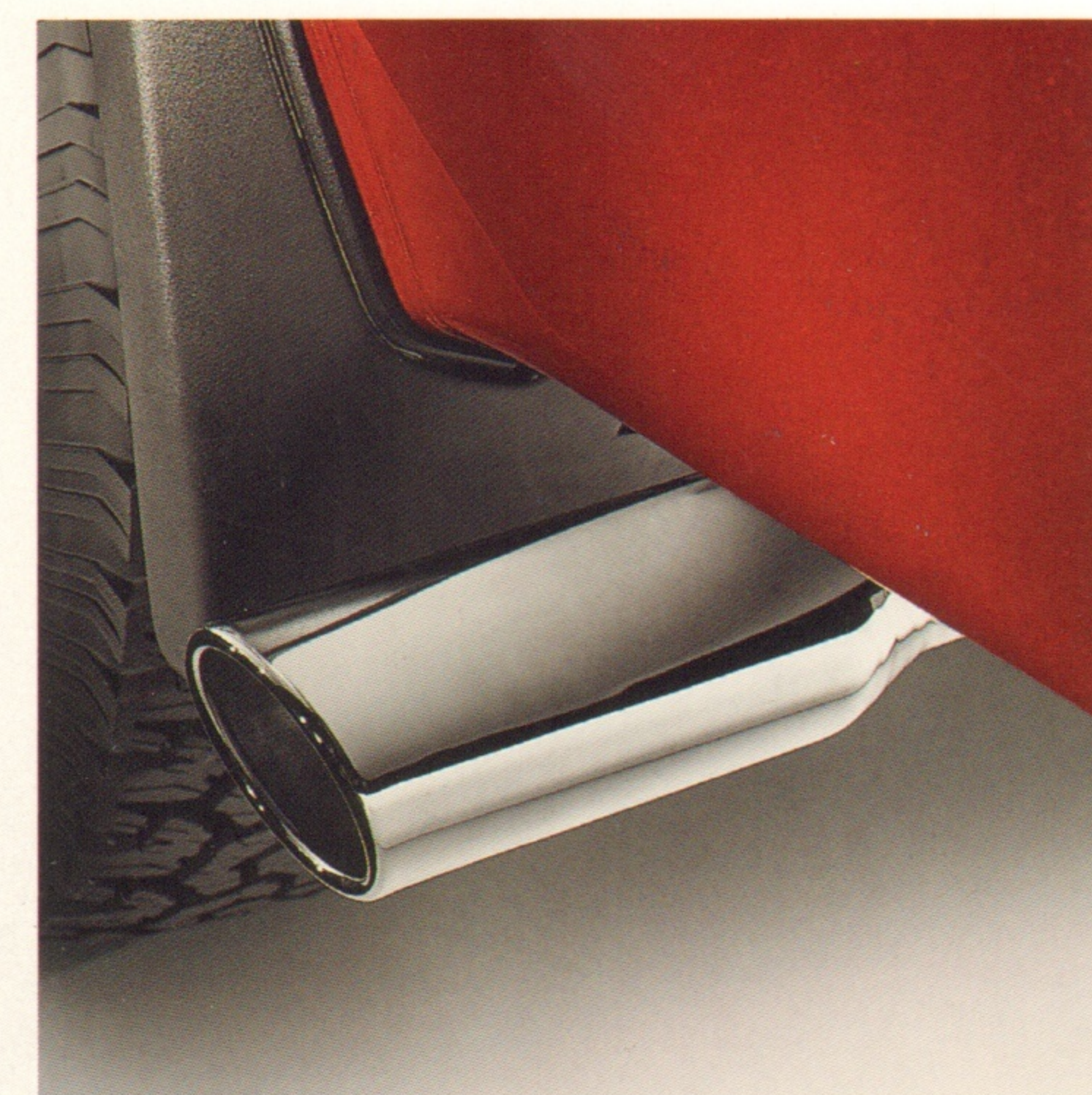

Exhaust Finisher



Mudguards



Side Steps

### CUSTOMIZE YOUR RAIDER EVEN FURTHER WITH THESE ADDITIONAL ACCESSORIES.

EXTERIOR: Fender Flares, Front Fascia Plate, Bed Mat, Folding Tonneau Cover, Snapless Tonneau, Hard Tonneau, Spare Tire Lock, Wheel

Locks, Trailer Hitch Wiring Harness, Trailer Hitch Receiver, Bed Web Net, Engine Block Heater, Touch-up Paint Pens, License Plate Frames

INTERIOR: Special Edition Floor Mats, All-weather Floor Mats (front), Raider Logo Floor Mats, SIRIUS® Satellite Radio





MITSUBISHI  
MOTORS

*Driven to Thrill*



[mitsubishicars.com](http://mitsubishicars.com)

1-888-MITSU2006

NATLBRO-06-007

DEZO'S GARAGE

