

F-650/F-750 SUPER DUTY FORD LCF 09

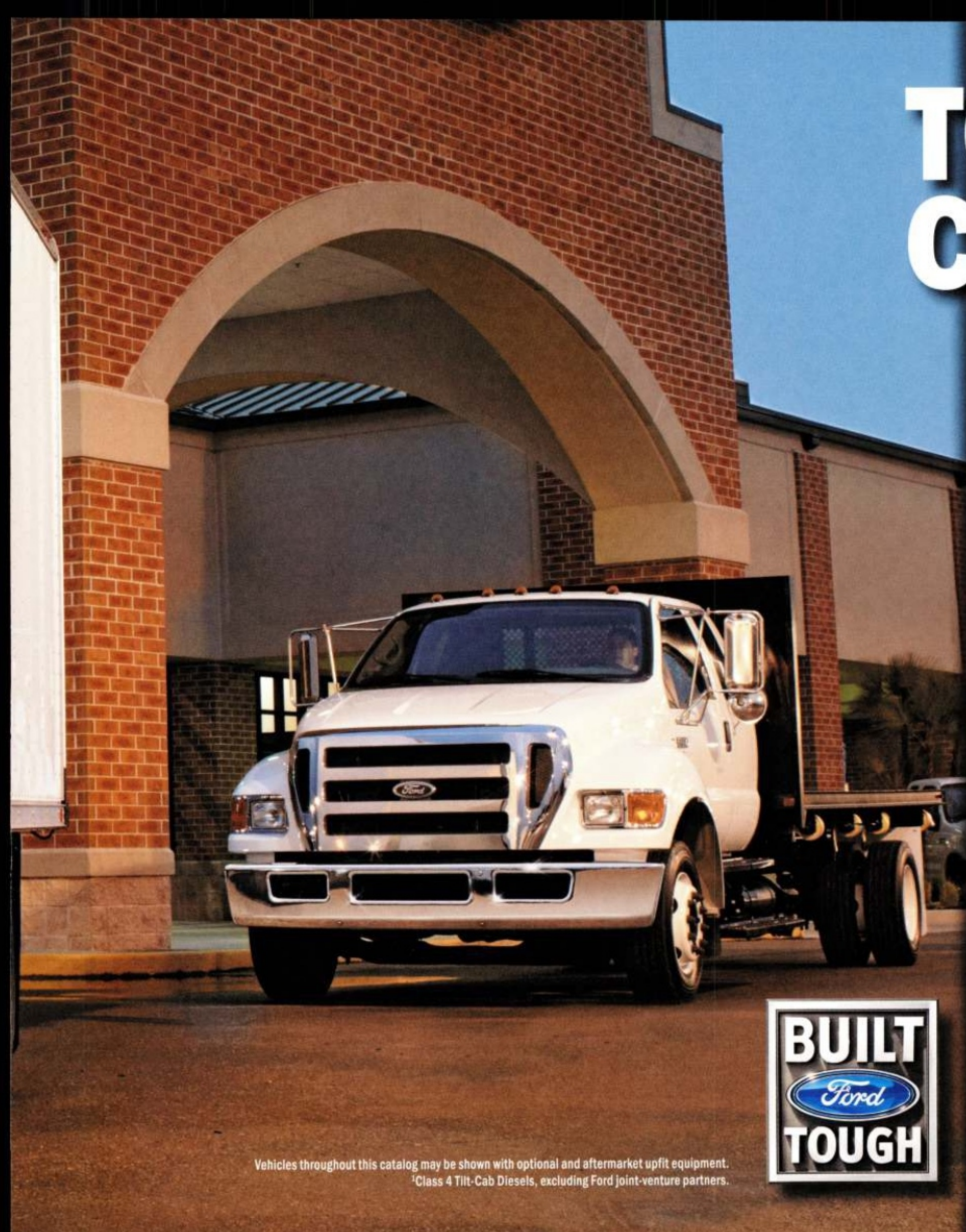

BIG TRUCKS FOR BIG JOBS



# TONS OF CAPABILITY

**TONS OF CHOICES** What are you looking for in a medium-duty truck? Maneuverability? Clean CA? Powertrain flexibility? Massive axle capacities? Ford's got you covered on all fronts.

## F-650/F-750 SUPER DUTY®

These trucks have proven themselves in a wide variety of vocations for decades. With GVWRs from 20,000 to 37,000 lbs., you have a huge range of capacities to choose from. 6.7L Cummins® ISB and Caterpillar® C7 turbo diesels with 17 horsepower and torque ratings, including a high-horsepower/medium-torque Cummins ISB with a standard automatic transmission, offer you powertrains to fit your needs. The maximum available front axle rating is 14,000 lbs., while rear axles top out at a beefy 23,000 lbs. Need extra electrical power? You can get up to a 270-amp alternator on select models. And, of course, Regular Cab, SuperCab and Crew Cab models let you pick the right size for your crews.

## FORD LCF |

Its maneuverability leads the low-cab-forward class.<sup>1</sup> With outstanding capability, muscular horsepower and torque, plus right-on-time customer service, Ford LCF is one formidable cargo hauler. You'll conquer city delivery with agility, efficiency and style — thanks to a choice of 9 exterior colors at no extra charge, and the extra-sharp looks of the optional Chrome Package. Of course, it's Built Ford Tough® on a standard frame unmatched for strength (RBM) in the class, including class-exclusive Huck Bolt™ construction for exceptional frame integrity and longevity.



Vehicles throughout this catalog may be shown with optional and aftermarket upfit equipment.  
<sup>1</sup>Class 4 Tilt-Cab Diesels, excluding Ford joint-venture partners.



F-650  
F-750

SUPER DUTY: NOTHING TOUGHER

### NEW FOR 2009

F-750 CAN NOW BE MADE CLASS 8-CAPABLE WITH A GVWR OF UP TO 37,000 LBS.

EATON'S FULLER® ULTRASHIFT® 6-SPEED FULLY AUTOMATED OVERDRIVE TRANSMISSION (AVAILABLE)

STANDARD MERITOR®-WABCO HPB BRAKE SYSTEM WITH MERITOR QUADRAULIC™ CALIPERS WITH ON-BOARD DATA ACQUISITION/DRIVER SUPERVISION SYSTEM

CUMMINS® VERTICAL EXHAUST (AVAILABLE)

AVAILABLE OVERHEAD GAUGE CLUSTER WITH OIL TEMP AND HOUR METER

XLT STANDARD CLOTH SEATS

160-AMP ALTERNATOR (AVAILABLE)

# BRUTE STRENGTH

## BACKBONE FOR BUSINESS

Year after year, F-650 and F-750 deliver legendary hauling and towing strength along with a huge range of upfit possibilities.

A host of standard and optional upgrades enhance their flexibility, comfort and utility. As always, every F-Series is backed by a solid warranty, outstanding service, and the reputation of Built Ford Tough®. These capable, durable, top-of-the-line Ford trucks can help you take care of business every day.

## NEW STANDARD

### HPB/QUADRAULIC BRAKE SYSTEM

This new system combines Meritor-WABCO's Hydraulic Power Brake (HPB) control and Meritor Quadraulic calipers. HPB delivers Anti-lock Brake System (ABS) and Automatic Traction Control (ATC) capabilities while Quadraulic disc calipers deliver serious stopping power through a 4-piston design. The Quadraulic fixed-caliper configuration helps eliminate environmental wear and tear that afflicts conventional rail or pin slider calipers. Simplified maintenance complements the rugged construction. Just loosen a retention bolt to remove worn-out linings and drop in new ones — no need to remove the brake hose or swing the caliper.



F-650  
F-750

SUPER DUTY® YOUR WAY



### 4-DOOR SUPERCAB

Extra room isn't nearly as big a benefit if it's hard to get to. That's why F-650 and F-750 offer the convenience of a 4-door SuperCab design. Two additional doors give you wide-open access to 2nd-row seating, and the rear bench seat flips up to reveal a king-size loadfloor.

FLEX  
ZONE



### F-650 AND F-750 ACCENTUATE THE FLEXIBLE

You can choose from 13 clean CA dimensions (available from 60" to 186"), chassis heights of 34", 39", or 40", and numerous wheelbase, chassis equipment and cab configurations. Ford packages critical components within all these configurations to help facilitate upfitting. These features make F-650 and F-750 some of the most versatile upfit vehicles on the road.



REGULAR CAB



SUPERCAB



CREW CAB

#### PACKAGING KEY

- Fuel Tank
- Exhaust Aftertreatment
- Battery Box
- Air Tanks
- Air Dryer

#### FUEL TANK PACKAGING

F-650 and F-750 offer 31 fuel tank combinations. Deep tanks are available, or choose shallow tank models that provide up to 19" of ground clearance. Get the tank style and location that your upfit calls for.

Caterpillar® exhaust aftertreatment shown.

#### AIR TANK PACKAGING

Every cab style and air brake system offered places the air tanks adjacent to the frame rails and under the cab. The advantages are cleaner CAs and protected positioning for the tanks.

Cummins® exhaust aftertreatment shown.

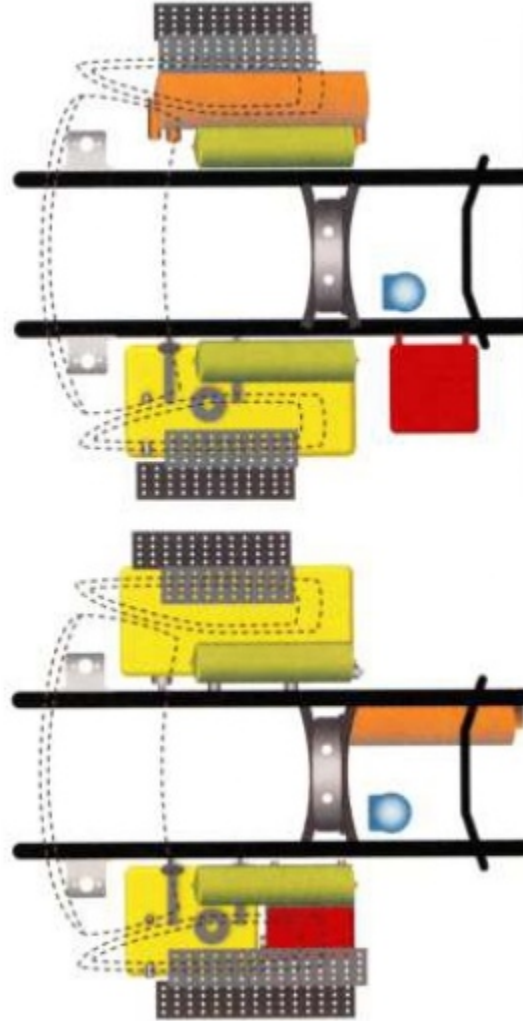

### NEW XLT SEATS

For 2009, the standard seats in XLT have been redesigned. The new seats feature supportive materials and contours for all-day comfort. The standard upholstery is a durable, breathable cloth, with vinyl as a no-cost option. Both the driver seat and the 2-person passenger seat include integrated outboard head restraints, improved bolsters and forward dump.



F-650  
F-750

ALL THE POWER YOU NEED

## UP TO 325 HP AND OUTSTANDING VALUE

With horsepower ranging from 200 to 325, and torque from 520 to 750 lb.-ft., Cummins® ISB offers you an outstanding selection. The available 300-hp/620-lb.-ft. torque engine with a 2000-Series Allison® automatic transmission makes an excellent mid-range choice.



### CUMMINS ISB

ENGINE TYPE	Turbo Diesel
DISPLACEMENT	6.7 Liters
MAXIMUM RATED HORSEPOWER	325 @ 2600 rpm
MAXIMUM PEAK TORQUE	750 lb.-ft. @ 1800 rpm

## CUMMINS ISB TURBO DIESEL

The ISB has excellent power-to-weight ratios in its class. Combine that with full-authority electronic controls, a high-pressure common-rail fuel-injection system, 24-valve design and its variable-geometry turbo, and you've got an engine that delivers fuel-sipping economy as it delivers every load.

F-650 Pro Loader<sup>®</sup>

F-650<sup>1</sup>

F-750

● ● ●	200 hp/520 lb.-ft. torque
● ● ●	220 hp/520 lb.-ft. torque
● ● ●	240 hp/560 lb.-ft. torque
● ● ●	240 hp/620 lb.-ft. torque
● ● ●	260 hp/620 lb.-ft. torque
● ● ●	280 hp/660 lb.-ft. torque
● ● ●	300 hp/620 lb.-ft. torque
● ● ●	325 hp/750 lb.-ft. torque

● Available

<sup>1</sup>Badged as Pro Loader when equipped with 19.5" wheels.



## TRANSMISSIONS

TRANSMISSION AVAILABILITY	HORSEPOWER RATINGS
<b>ALLISON AUTOMATIC</b>	
Allison 2200 5-Speed	200/220/240/240H/260/300
Allison 2500 5-Speed	200/220/240/240H/260/300
Allison 3000 5-Speed	240H/260/280/300/325
Allison 3000 6-Speed	240H/260/280/300/325
Allison 3200 5-Speed	240H/260/280/300/325
Allison 3200 6-Speed	240H/260/280/300/325
Allison 3500 5-Speed	240H/260/280/300/325
Allison 3500 6-Speed	240H/260/280/300/325

### FULLER<sup>®</sup> MANUAL

Fuller FS-5205A 5-Speed	200/220
Fuller FS-5406A 6-Speed	200/220/240
Fuller FO-5406B <sup>2</sup> 6-Speed	200/220/240/240H/260/300
Fuller FS-6406A 6-Speed	220/240/240H/260/280/300
Fuller FO-6406B <sup>2</sup> 6-Speed	220/240/240H/260/280/300
Fuller FSO-6406A 6-Speed	220/240/240H/260/280/300
Fuller FSO-8406A 6-Speed	280/300/325

### SPICER<sup>®</sup> MANUAL

Spicer ES56-7B 7-Speed	200/220/240
Spicer ESO66-7B 7-Speed	220/240/240H/260/280/300

H = High-torque engine. <sup>2</sup>Governed speed.

## SERIOUS TORQUE FOR THE TOUGHEST TASKS

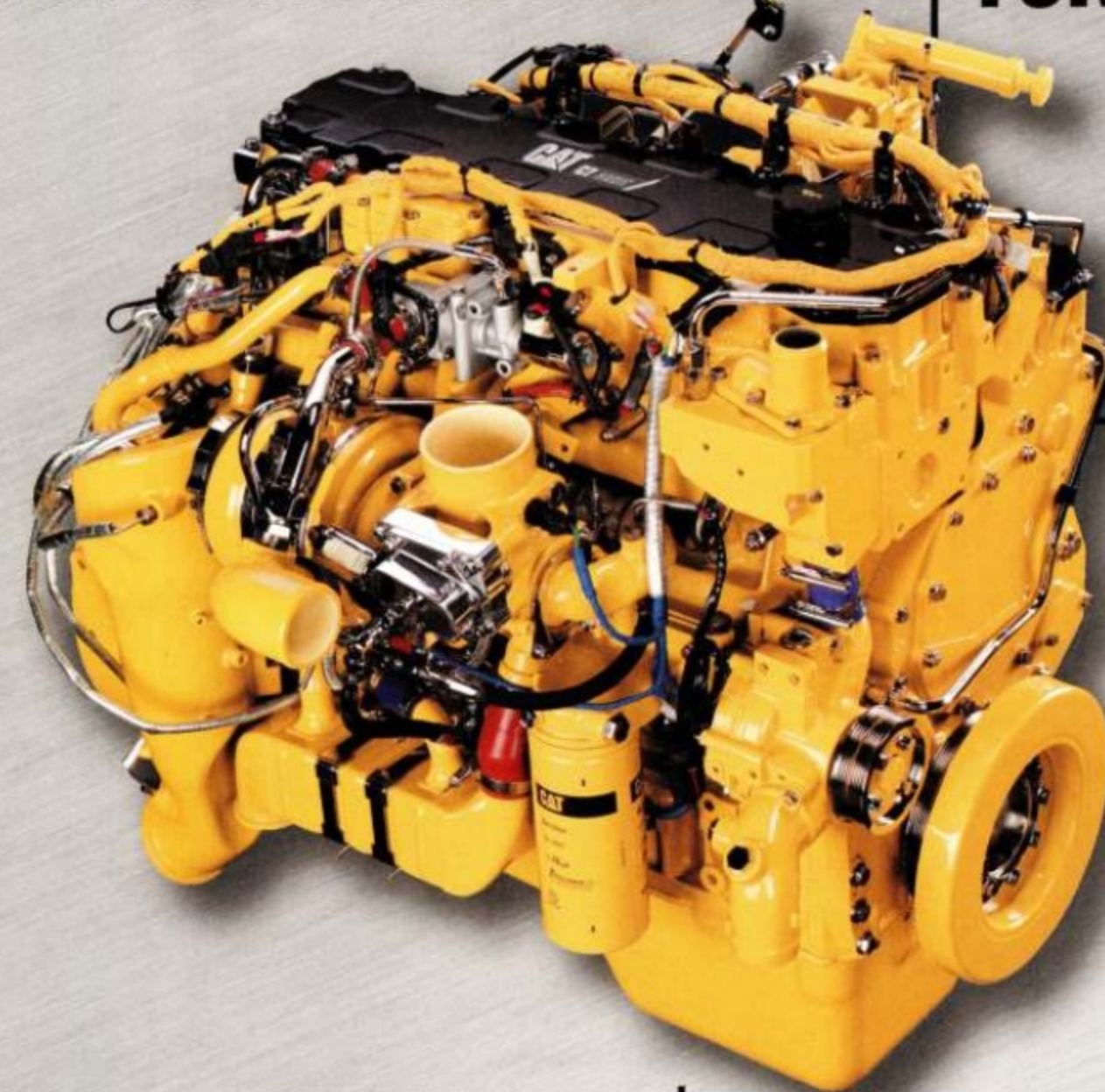

## CATERPILLAR C7 TURBO DIESEL

Caterpillar C7 offers versatility and strength with torque values up to a crushing 860 lb.-ft. All powerplants run exclusively on ultra-low-sulfur diesel. (Limited availability.)

### CATERPILLAR C7

ENGINE TYPE	Turbo Diesel
DISPLACEMENT	7.2 Liters
MAXIMUM RATED HORSEPOWER	300 @ 2200 rpm
MAXIMUM PEAK TORQUE	860 lb.-ft. @ 1440 rpm

F-650 Pro Loader<sup>®</sup>

F-650<sup>1</sup>

F-750

● ● ●	210 hp/520 lb.-ft. torque
● ● ●	210 hp/620 lb.-ft. torque
● ● ●	230 hp/560 lb.-ft. torque
● ● ●	230 hp/620 lb.-ft. torque
● ● ●	230 hp/660 lb.-ft. torque
● ● ●	250 hp/660 lb.-ft. torque
● ● ●	250 hp/800 lb.-ft. torque
● ● ●	275 hp/800 lb.-ft. torque
● ● ●	300 hp/860 lb.-ft. torque

● Available



## TRANSMISSIONS

TRANSMISSION AVAILABILITY	HORSEPOWER RATINGS
<b>ALLISON AUTOMATIC</b>	
Allison 2200 5-Speed	210/210H/230/230M
Allison 2500 5-Speed	210/210H/230/230M
Allison 3000 5-Speed	210H/230M/230H/250/250H/275/300
Allison 3000 6-Speed	210H/230M/230H/250/250H/275/300
Allison 3200 5-Speed	230H/250/250H/275/300
Allison 3200 6-Speed	230H/250/250H/275/300
Allison 3500 5-Speed	210H/230M/230H/250/250H/275/300
Allison 3500 6-Speed	210H/230M/230H/250/250H/275/300

### FULLER MANUAL

Fuller FS-5205A 5-Speed	210
Fuller FS-5406A 6-Speed	210/240
Fuller FO-5406B <sup>2</sup> 6-Speed	210/210H/230/230M
Fuller FS-6406A 6-Speed	210/210H/230/230M/230H/250
Fuller FO-6406B <sup>2</sup> 6-Speed	210/210H/230/230M/230H/250
Fuller FSO-6406A 6-Speed	210/210H/230/230M/230H/250
Fuller FSO-8406A 6-Speed	250H/275/300

### SPICER MANUAL

Spicer ES56-7B 7-Speed	210/230
Spicer ESO66-7B 7-Speed	210/210H/230/230M/230H/250

H = High-torque engine. M = Mid-torque engine.

## NEW EATON'S FULLER<sup>®</sup> ULTRASHIFT<sup>®</sup>

A new option on the 2009 F-650/F-750, the Fuller UltraShift fully automated 6-speed is feature packed. Its automatic operation helps lessen driver fatigue, and Hill Assist minimizes rolling when the truck is stopped on a grade. A standard 6-bolt PTO opening offers easy access to accessory power. Plus, an up to 500,000-mile service interval<sup>3</sup> helps reduce operating costs even more. Serious economy and convenient features help make UltraShift a terrific value.

<sup>3</sup>Under normal driving conditions.

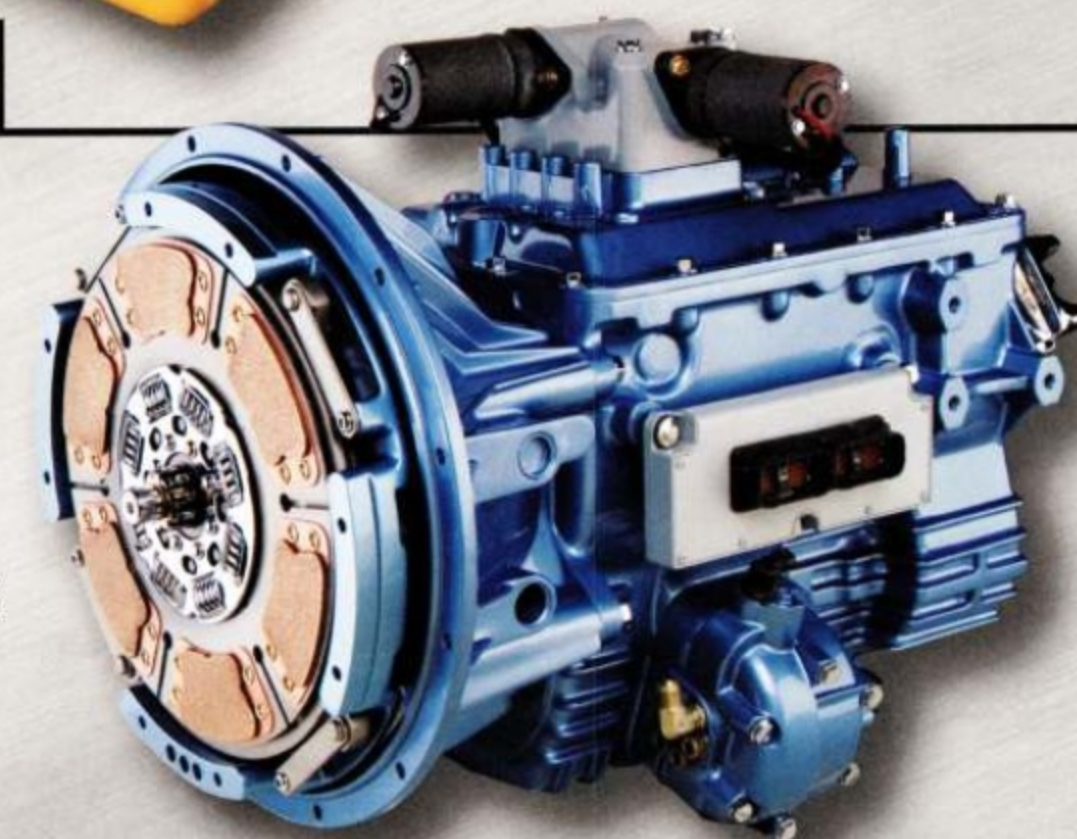

FEATURES & OPTIONS

F-650 Pro Loader*		
F-650'		
F-750		
AXLE & SUSPENSION – FRONT		
<input type="checkbox"/>	<input type="checkbox"/>	Auxiliary springs – Rubber
<input type="checkbox"/>	<input type="checkbox"/>	Axle lube – EmGard® 50W synthetic oil
<input checked="" type="checkbox"/>	<input checked="" type="checkbox"/>	Shock absorbers – Double-acting
<input checked="" type="checkbox"/>	<input checked="" type="checkbox"/>	Wheel seals – STEMCO® Guardian® with mineral oil-lubricated wheel bearings
AXLE & SUSPENSION – REAR		
<input type="checkbox"/>	<input type="checkbox"/>	Air suspension (requires air brakes or compressor)
—	<input type="checkbox"/>	Air suspension leveling valve
<input type="checkbox"/>	<input type="checkbox"/>	Air suspension dump valve
<input type="checkbox"/>	<input type="checkbox"/>	Axle lube – EmGard 75W-90 synthetic oil
<input checked="" type="checkbox"/>	<input checked="" type="checkbox"/>	Multi-leaf springs – Vari-rate suspension
<input checked="" type="checkbox"/>	<input checked="" type="checkbox"/>	Shock absorbers
<input checked="" type="checkbox"/>	<input checked="" type="checkbox"/>	Wheel seals – STEMCO with mineral oil-lubricated wheel bearings
BRAKES & BRAKE EQUIPMENT		
—	<input checked="" type="checkbox"/>	ABS – Meritor® Quadraulic™ 4-channel Anti-lock Brake System (70-mm pistons)
<input checked="" type="checkbox"/>	<input type="checkbox"/>	ABS – Meritor Quadraulic 4-channel Anti-lock Brake System (64-mm pistons)
<input type="checkbox"/>	<input type="checkbox"/>	Air brake with traction control – Automatic
<input type="checkbox"/>	<input type="checkbox"/>	Air brake system – Straight truck use only
—	<input type="checkbox"/>	Air brake system – Tractor use only (Regular Cab and SuperCab only)
<input type="checkbox"/>	<input type="checkbox"/>	Air compressor – Caterpillar® engines: standard 13.2-CFM capacity on F-650 Pro Loader; all others 16.1-CFM
<input type="checkbox"/>	<input type="checkbox"/>	Air compressor – Cummins® engines: Wabco® 18.7-CFM capacity
<input type="checkbox"/>	<input type="checkbox"/>	Air dryer – Bendix® AD/IP with heater: mounted on back of cab, inside left frame rail (not available with Hydraulic Brake System)
<input type="checkbox"/>	<input type="checkbox"/>	Air tank location – Under cab
<input type="checkbox"/>	<input type="checkbox"/>	Drain valve (1) – Automatic (Bendix DV-2) with heater
—	<input type="checkbox"/>	Hydraulic Brake System with Traction Control – Automatic (70-mm pistons)
<input type="checkbox"/>	<input type="checkbox"/>	Hydraulic Brake System with Traction Control – Automatic (64-mm pistons)
<input checked="" type="checkbox"/>	<input checked="" type="checkbox"/>	Parking brake – Bosch DSSA type, 12" x 3", rear axle-mounted
<input checked="" type="checkbox"/>	<input checked="" type="checkbox"/>	Parking brake control
TRAILER CONNECTIONS		
<input type="checkbox"/>	<input type="checkbox"/>	Trailer Air Brake Package – 4-wheel
<input type="checkbox"/>	<input type="checkbox"/>	Trailer connection socket – 7-way
FUEL TANKS		
<input checked="" type="checkbox"/>	<input checked="" type="checkbox"/>	Steel – Shallow (13" depth)
—	<input type="checkbox"/>	Steel – Deep (16" depth)
ENGINE EQUIPMENT		
<input checked="" type="checkbox"/>	<input checked="" type="checkbox"/>	Air cleaner – Donaldson® with restriction gauge
<input type="checkbox"/>	<input type="checkbox"/>	Engine block heater
<input type="checkbox"/>	<input type="checkbox"/>	Engine exhaust brake
<input checked="" type="checkbox"/>	<input checked="" type="checkbox"/>	Fan clutch – BorgWarner
<input type="checkbox"/>	<input type="checkbox"/>	Fuel tanks – Dual with transfer pump

● Standard ● Select Availability ○ Optional — Not Available

\*Badged as Pro Loader when equipped with 19.5" wheels.

F-650 Pro Loader		
F-650'		
F-750		
ENGINE EQUIPMENT (continued)		
<input checked="" type="checkbox"/>	<input checked="" type="checkbox"/>	Fuel/water separator – Fleetguard®, electric type, heated
<input type="checkbox"/>	<input type="checkbox"/>	Fuel/water separator – Racor®, electric, heated (Caterpillar engines)
<input checked="" type="checkbox"/>	<input checked="" type="checkbox"/>	Radiator – 717 sq.-in. cross-flow, aluminum, 4.25" core
<input checked="" type="checkbox"/>	<input checked="" type="checkbox"/>	Starting motor – 12-volt
DRIVELINES & CLUTCHES		
<input type="checkbox"/>	<input type="checkbox"/>	Clutch – Fuller® 14", single-plate, adjustment-free
<input type="checkbox"/>	<input type="checkbox"/>	Clutch – Fuller 14", 2-plate, adjustment-free
<input checked="" type="checkbox"/>	<input checked="" type="checkbox"/>	Driveline – Spicer® SPL100
<input type="checkbox"/>	<input type="checkbox"/>	Driveline – Spicer SPL140
<input type="checkbox"/>	<input type="checkbox"/>	Synthetic transmission oil – EmGard 50W for manual transmissions
<input type="checkbox"/>	<input type="checkbox"/>	Synthetic transmission oil – Castrol® TranSynd™ for Allison® automatic transmissions
EXHAUST		
<input checked="" type="checkbox"/>	<input checked="" type="checkbox"/>	Single, horizontal aftertreatment device, frame-mounted on back of cab, under right rail, horizontal tailpipe, right-side outlet with heat diffuser (Cummins engines only)
<input checked="" type="checkbox"/>	<input checked="" type="checkbox"/>	Single, horizontal aftertreatment device, frame-mounted under cab, outside right rail, horizontal tailpipe, right-side outlet with heat diffuser (standard on Caterpillar)
<input type="checkbox"/>	<input type="checkbox"/>	Single, horizontal aftertreatment device, frame-mounted under cab, outside right rail, vertical non-bright tailpipe, right-side outlet
<input type="checkbox"/>	<input type="checkbox"/>	Single, horizontal aftertreatment device, frame-mounted under cab, outside right rail, horizontal tailpipe, left-side outlet with heat diffuser
<input type="checkbox"/>	<input type="checkbox"/>	Rain cap, non-bright-finish – For vertical exhaust (Caterpillar only)
ELECTRICAL		
<input checked="" type="checkbox"/>	<input checked="" type="checkbox"/>	Alternator – 130-amp Leece-Neville
<input type="checkbox"/>	<input type="checkbox"/>	Alternators – 130-, 160-, 200- or 270-amp
<input type="checkbox"/>	<input type="checkbox"/>	Backup alarm – Electric, 102 decibels
<input checked="" type="checkbox"/>	<input checked="" type="checkbox"/>	Batteries – 625 CCA (2 for a total of 1250 CCA)
<input type="checkbox"/>	<input type="checkbox"/>	Batteries – 900 CCA (2 for a total of 1800 CCA)
<input type="checkbox"/>	<input type="checkbox"/>	Batteries – 625 CCA (3 for a total of 1875 CCA)
<input type="checkbox"/>	<input type="checkbox"/>	Batteries – 900 CCA (3 for a total of 2700 CCA)
<input checked="" type="checkbox"/>	<input checked="" type="checkbox"/>	Battery box – Aft of fuel tank
<input type="checkbox"/>	<input type="checkbox"/>	Battery – Temporary mount (dual 625 CCA batteries only)
<input checked="" type="checkbox"/>	<input checked="" type="checkbox"/>	Body-builder wiring – At back of cab at frame
—	<input type="checkbox"/>	Body-builder special beverage wiring harness
<input type="checkbox"/>	<input type="checkbox"/>	Body-builder wiring – To end of frame
<input type="checkbox"/>	<input type="checkbox"/>	Daytime running lamps (not standard in U.S.)
<input checked="" type="checkbox"/>	<input checked="" type="checkbox"/>	Electrical system – 12-volt
<input checked="" type="checkbox"/>	<input checked="" type="checkbox"/>	Emergency flashers
<input checked="" type="checkbox"/>	<input checked="" type="checkbox"/>	Fuses – SAE blade-type
<input checked="" type="checkbox"/>	<input checked="" type="checkbox"/>	Headlamps – Rectangular halogen sealed-beam (includes front-side marker lamps with reflectors)
<input type="checkbox"/>	<input type="checkbox"/>	Jump-start stud – Remote-mounted
<input type="checkbox"/>	<input type="checkbox"/>	Stop, turn, tail and backup lamps (includes separate rear reflectors; does not include power module or rubber mounts)
—	<input type="checkbox"/>	Taillamps – 2 with integrated stop, turn signal, backup and license plate
<input type="checkbox"/>	<input type="checkbox"/>	Taillamps – Delete
<input type="checkbox"/>	<input type="checkbox"/>	Turn-signal lamps – Fender-mounted, front- and rear-facing

F-650 Pro Loader		
F-650'		
F-750		
CAB EQUIPMENT		
<input checked="" type="checkbox"/>	<input checked="" type="checkbox"/>	<b>XL Trim Package</b> – Includes molded-cloth headliner; LH/RH coat hooks; hi-back driver seat with 2-person passenger seat; G-grain vinyl seat trim; 2nd-row bench (SuperCab and Crew Cab); cloth sun visors with passenger-side mirror; exterior body-color-painted back panel; door-trim panels with reflector; manual air conditioning; chrome headlamp bezels; chrome grille; and chrome front bumper (XL only)
<input checked="" type="checkbox"/>	<input checked="" type="checkbox"/>	<b>XLT Trim Package</b> – Includes molded-cloth headliner; LH/RH coat hooks; hi-back driver and passenger seats with integrated head restraints and folding/reclining backs; Mortar cloth seat trim with Marta cloth insert; 2nd-row bench (SuperCab and Crew Cab); cloth sun visors with passenger-side mirror; Rigitex back-panel trim; molded door-trim panels with lower map pocket and carpet on face; manual air conditioning; Power Equipment Group, including power windows and door locks; AM/FM stereo with single-CD player; front tow hooks; chrome headlamp bezels; chrome grille; chrome front bumper (XLT only)
CAB EQUIPMENT – EXTERIOR		
<input checked="" type="checkbox"/>	<input checked="" type="checkbox"/>	Assist handles – B-pillar with Regular Cab
<input checked="" type="checkbox"/>	<input checked="" type="checkbox"/>	Assist handles – Rear doors with SuperCab
<input checked="" type="checkbox"/>	<input checked="" type="checkbox"/>	Assist handles – Rear passengers, C-pillars with Crew Cab
—	<input checked="" type="checkbox"/>	Frame extension – Front bolt-on type, 20" without crossmember (requires fixed grille, swept back front bumper or front bumper delete)
<input checked="" type="checkbox"/>	<input checked="" type="checkbox"/>	Front bumper – Full-width, chrome-steel
<input type="checkbox"/>	<input type="checkbox"/>	Front bumper – Full-width, painted-steel, Dark Shadow Grey color (XL only)
—	<input checked="" type="checkbox"/>	Front bumper – Swept back, Dark Shadow Grey color (requires frame extension)
<input type="checkbox"/>	<input type="checkbox"/>	Front bumper – Delete
<input checked="" type="checkbox"/>	<input checked="" type="checkbox"/>	Front-end tilting fiberglass hood and fenders assembly – Frame-mounted with torsion-bar assist (includes integrated noise shield, inner splash shields and mud flaps)
<input checked="" type="checkbox"/>	<input checked="" type="checkbox"/>	Glass – Laminated windshield, solar-tinted all around
<input type="checkbox"/>	<input type="checkbox"/>	Glass – Privacy glass (tinted rear sliding and rear cab windows for SuperCab and Crew Cab)
<input checked="" type="checkbox"/>	<input checked="" type="checkbox"/>	Grille – Chrome (includes chrome headlamp bezels)
<input type="checkbox"/>	<input type="checkbox"/>	Grille – Dark Shadow Grey
<input type="checkbox"/>	<input type="checkbox"/>	Grille – Fixed, Dark Shadow Grey
<input checked="" type="checkbox"/>	<input checked="" type="checkbox"/>	Horn – Dual electric
<input type="checkbox"/>	<input type="checkbox"/>	Horn – Air, black, single trumpet
<input checked="" type="checkbox"/>	<input checked="" type="checkbox"/>	Lamps – Roof marker/clearance (5)
<input type="checkbox"/>	<input type="checkbox"/>	License plate holder, front – Includes upper and lower mounting-plate hardware
<input checked="" type="checkbox"/>	<input checked="" type="checkbox"/>	Mirrors – Dual rectangular, 7.5" x 16.5" stainless steel, West Coast-style, 102"-wide spacing
<input type="checkbox"/>	<input type="checkbox"/>	Mirrors – Dual stainless steel with heated and lighted heads, rectangular, 7.5" x 16.5", West Coast-style, 102"-wide spacing
<input type="checkbox"/>	<input type="checkbox"/>	Mirrors – Auxiliary convex (2), stainless steel, 8" diameter, mounted below primary mirrors (available only with dual stainless steel West Coast-style mirrors)
<input type="checkbox"/>	<input type="checkbox"/>	Mirrors – Sail-type, power, 8" x 9" with 8" x 3" integrated convex mirrors, telescoping breakaway-type brackets (XLT only)
—	<input type="checkbox"/>	Mudflap holders – Spring-loaded, painted black, with red and white reflective tape
—	<input type="checkbox"/>	Mudflaps, rear – Black rubber, anti-sail
<input type="checkbox"/>	<input type="checkbox"/>	Power Equipment Group Delete – 2 power windows with power door locks (4 with Crew Cab) (XLT only)
<input type="checkbox"/>	<input type="checkbox"/>	Tow hooks, front – Frame-mounted (2) (standard on XLT)
<input checked="" type="checkbox"/>	<input checked="" type="checkbox"/>	Window, rear – Fixed
<input checked="" type="checkbox"/>	<input checked="" type="checkbox"/>	Windshield wipers – 2-speed intermittent with washers

F-650 Pro Loader		
F-650'		
F-750		
CAB EQUIPMENT – INTERIOR		
<input checked="" type="checkbox"/>	<input checked="" type="checkbox"/>	Air conditioning – Manual, includes integral heater and defroster
<input type="checkbox"/>	<input type="checkbox"/>	Air conditioning – Delete (XL only)
<input checked="" type="checkbox"/>	<input checked="" type="checkbox"/>	Air registers – LH, LHC, RHC with positive shutoff
<input checked="" type="checkbox"/>	<input checked="" type="checkbox"/>	AM/FM stereo with clock and 2 speakers (XL only)
<input type="checkbox"/>	<input type="checkbox"/>	AM/FM stereo with single-CD player, clock and 4 speakers (standard on XLT)
<input type="checkbox"/>	<input type="checkbox"/>	AM/FM stereo with 6-disc in-dash CD changer, clock and 4 speakers
<input type="checkbox"/>	<input type="checkbox"/>	Radio – Delete
<input checked="" type="checkbox"/>	<input checked="" type="checkbox"/>	Assist handle – Front-passenger, B-pillar
<input checked="" type="checkbox"/>	<input checked="" type="checkbox"/>	Auxiliary power point – Instrument panel
<input checked="" type="checkbox"/>	<input checked="" type="checkbox"/>	Back panel cover – Rigitex (XLT Regular Cab only)
<input checked="" type="checkbox"/>	<input checked="" type="checkbox"/>	Cigar lighter – Instrument panel
<input type="checkbox"/>	<input type="checkbox"/>	Console – Floor-mounted between front seats
<input checked="" type="checkbox"/>	<input checked="" type="checkbox"/>	Cruise control – Instrument panel-mounted
<input checked="" type="checkbox"/>	<input checked="" type="checkbox"/>	Cupholders – Instrument panel
<input checked="" type="checkbox"/>	<input checked="" type="checkbox"/>	Demisters – LH/RH side-window
<input checked="" type="checkbox"/>	<input checked="" type="checkbox"/>	Dome light – Center (LH/RH door-activated, I/P switch-operated with delay)
<input checked="" type="checkbox"/>	<input checked="" type="checkbox"/>	Floor covering – Black, full, Maslite-type
<input checked="" type="checkbox"/>	<input checked="" type="checkbox"/>	Gauge cluster – Includes electronic speedometer (mph, km/h), trip odometer, voltmeter, oil pressure, coolant temperature, fuel gauge, tachometer and indicator lights
<input type="checkbox"/>	<input type="checkbox"/>	Gauge cluster, overhead, non-Eaton automatic transmission – Includes oil temperature and hour meter
<input checked="" type="checkbox"/>	<input checked="" type="checkbox"/>	Grab handle – Front-passenger, A-pillar-mounted
<input checked="" type="checkbox"/>	<input checked="" type="checkbox"/>	Instrument panel – Color-keyed with color-coordinated accents
<input type="checkbox"/>	<input type="checkbox"/>	Leather Trim Package – Includes leather-trimmed front captain's chairs, front floor mats, power windows and locks, carpeting, dual cloth sun visors, and center floor console between front seats (XLT only)
<input type="checkbox"/>	<input type="checkbox"/>	Passenger seat – Delete
<input type="checkbox"/>	<input type="checkbox"/>	Rear seat – Delete (SuperCab or Crew Cab)
<input checked="" type="checkbox"/>	<input checked="" type="checkbox"/>	Safety belts <sup>2</sup> – Belt-Minder® system (chime and flashing warning light on instrument panel if driver safety belt isn't buckled)
<input checked="" type="checkbox"/>	<input checked="" type="checkbox"/>	Safety belts <sup>2</sup> – Color-keyed, all positions include fixed D-rings (Regular Cab)
<input checked="" type="checkbox"/>	<input checked="" type="checkbox"/>	Safety belts <sup>2</sup> – Color-keyed, front-seat adjustable D-rings (SuperCab or Crew Cab)
<input checked="" type="checkbox"/>	<input checked="" type="checkbox"/>	Scuff plates – Color-keyed
<input checked="" type="checkbox"/>	<input checked="" type="checkbox"/>	Steering column – Tilt
<input checked="" type="checkbox"/>	<input checked="" type="checkbox"/>	Steering wheel – 2-spoke, black vinyl (15.5" diameter with 8500-lb. front axle; 17.5" diameter with 10,000-lb. front axle)
<input type="checkbox"/>	<input type="checkbox"/>	Steering wheel – 2-spoke, black leather-wrapped (15.5" diameter only) (XLT only)
<input checked="" type="checkbox"/>	<input checked="" type="checkbox"/>	Sun visors – Driver and passenger, cloth
<input checked="" type="checkbox"/>	<input checked="" type="checkbox"/>	Turn-signal switch – Multifunction, self-canceling
—	<input type="checkbox"/>	Turn-signal switch – Non-self-canceling (tractor use only)
<input checked="" type="checkbox"/>	<input checked="" type="checkbox"/>	Utility tray – Floor-mounted behind seat (XLT Regular or Crew Cab only)

<sup>2</sup>Always wear your safety belt.

F-650  
F-750

SPECIFICATIONS

**WEIGHT RATINGS & WHEELBASE/CAB-TO-AXLE RANGES**

MODEL	GVWR (LBS.)	CAB	WHEELBASE/CAB-TO-AXLE	
			RANGE (IN.)	OPTIONS
F-650 Pro Loader*	20,050 – 26,000	Regular Cab	134/60 – 242/168	6
		SuperCab	155/60 – 239/144	4
		Crew Cab	170/60 – 254/144	4
F-650 <sup>1</sup>	20,950 – 29,000	Regular Cab	146/72 – 260/186	13
		SuperCab	167/72 – 281/186	13
		Crew Cab	182/72 – 278/168	12
F-750	25,999 – 37,000	Regular Cab	146/72 – 281/207	15
		SuperCab	167/72 – 281/186	13
		Crew Cab	182/72 – 266/156	11



**FRAMES**

MODEL	FRAME ORDER CODE												
	533	534	535	536	537	538	539	530	53F	53A	53J	53L	412/410
F-650 Pro Loader	—	—	—	—	●	—	—	—	—	—	—	—	—
F-650 <sup>1</sup>	○	●	—	○	—	—	—	—	—	—	—	—	—
F-750	—	—	○	○	—	○	—	○	○	●	○	○	○
Depth (in.)	9.125	10.125	10.250	10.125	9.125	10.250	10.375	10.813	10.125	10.250	10.250	10.375	10.813
Width (in.)	3.062	3.062	3.092	3.580	3.062	3.610	3.705	3.892	3.580	3.092	3.610	3.705	3.892
Thickness (in.)	0.312	0.312	0.375	0.312	0.312	0.375	0.438	0.312	0.312	0.375	0.375	0.438	0.312
Yield (psi)	80,000	50,000	80,000	120,000	80,000	120,000	120,000	120,000	120,000	80,000	120,000	120,000	120,000
Maximum Section Modulus (cu. in.)	11.47	13.31	15.94	14.84	11.47	17.79	21.05	29.84	14.84	15.94	17.79	21.05	29.84
Max. Resisting Bending Moment (in.-lbs.)	917,600	665,500	1,275,200	1,780,800	917,600	2,134,800	2,526,000	3,580,800	1,780,800	1,275,200	2,134,800	2,526,000	3,580,800

**SUSPENSIONS**

MODEL	FRONT SPRING RATING (LBS.)					REAR MULTI-LEAF SPRINGS RATING (LBS.)						REAR AIR SUSPENSION RATING (LBS.)				
	8500	10,000	12,000	13,200	14,000	15,500	17,500	18,500	20,000	23,500	31,000	12,000	15,500	18,500	20,000	23,000
F-650 Pro Loader	●	—	—	—	—	—	●	—	—	—	—	○	○	○	—	—
F-650 <sup>1</sup>	●	○	—	—	—	○	—	●	○	—	—	—	—	○	○	—
F-750	—	●	○	○	○	—	—	—	—	●	○	—	—	—	○	○

**AXLES**

MODEL	FRONT AXLE RATING (LBS.)					REAR AXLE RATING (LBS.)									
						SINGLE SPEED					TWO SPEED				
	8500	10,000	12,000	13,200	14,000	13,500	15,500	17,500	19,000	21,000	23,000	17,500	19,000	21,000	23,000
F-650 Pro Loader	●	—	—	—	—	●	○	○	—	—	—	○	—	—	—
F-650 <sup>1</sup>	●	○	—	—	—	—	—	●	○	—	—	○	○	—	—
F-750	—	●	○	○	○	—	—	—	—	●	○	—	—	○	○

\*Badged as Pro Loader when equipped with 19.5" wheels.

● Standard ○ Optional — Not Available

F-650  
F-750

SEATING, TIRES & WHEELS

**SEATING**

		SEAT SUSPENSION SYSTEM	SEATING POSITION AVAILABILITY	XL	XLT
<b>STANDARD FRONT SEATS</b>					
	Captain's chair with hi-back integrated head restraint, dumping/reclining, armrest	Fixed-spring	Driver	●	○
	2-person, intermediate-back folding, outboard-position integrated head restraint, no armrest	Fixed-spring	Center/Passenger	●	○
	Hi-back split bench with outboard-position integrated head restraints, dumping/reclining	Fixed-spring	Driver/Center/Passenger	○	●
<b>OPTIONAL FRONT SEATS</b>					
	Air suspension hi-back bucket with integrated head restraint, dumping/limited reclining, includes armrest in SuperCab and Crew Cab models	Air suspension with integrated air compressor <sup>2</sup>	Driver	○	○
	Full Air-Ride hi-back buckets with integrated head restraints, dumping/full reclining, armrests	Air-Ride <sup>3</sup> /fixed-spring	Driver/Passenger	○	○
	Captain's chairs with hi-back integrated head restraints, dumping/full reclining, fore/aft isolation armrests (SuperCab and Crew Cab only)	Air-Ride/fixed-spring	Driver/Passenger	○	○
	Air suspension hi-back bucket seats with integrated head restraints, dumping/limited reclining, armrests	Air suspension with integrated air compressor <sup>2</sup>	Driver/Passenger	○	○
	Leather-trimmed front captain's chairs, front floor mats, power windows and door locks, carpeting, dual cloth sun visors and center floor console	Fixed-spring	Driver/Center/Passenger	—	○
<b>REAR SEATS<sup>4</sup></b>					
	3-person rear bench, full-width, split fold-up converts to loadfloor (SuperCab)	High-density foam	Rear bench	●	●
	3-person full-size rear bench, full-width, folding back (Crew Cab)	Fixed-spring	Rear bench	●	●

<sup>2</sup>Available only with Hydraulic Brake System. <sup>3</sup>Requires air brakes or air compressor option. <sup>4</sup>Rear seat is vinyl with leather-trimmed front seats.

**WHEEL AVAILABILITY**

	F-650 Pro Loader	F-650 <sup>1</sup>	F-750
19.5 x 6.75 8-lug white painted-steel	●	○	—
19.5 x 7.5 8-lug polished-aluminum <sup>5</sup>	○	○	—
19.5 x 7.5 10-lug white painted-steel	○	○	—
19.5 x 7.5 10-lug polished-aluminum <sup>5</sup>	○	○	—
22.5 x 7.5 10-lug white painted-steel	—	●	●
22.5 x 8.25 10-lug white painted-steel	—	○	○
22.5 x 8.25 10-lug polished-aluminum <sup>5</sup>	—	○	○
Wheel ornamentation – Ford bright center cap and lug nut covers	○	○	○

<sup>1</sup>Outer wheel only – inner rear wheel is steel.



Polished-Aluminum (front)



White Painted-Steel (front)

**TIRE AVAILABILITY**

F-650 Pro Loader	F-650 <sup>1</sup>	F-750	TIRE SIZE*	LOAD RANGE (PR)	STEEL	ALUMINUM
○	○	—	225/70R19.5F	12	○	—
○	○	—	225/70R19.5G	14	○	○
○	○	—	245/70R19.5F	12	○	○
●	○	—	245/70R19.5G	14	○	○
○	○	—	245/70R19.5H	16	○	○
○	○	—	265/70R19.5G	14	○	○
—	○	○	9R22.5F	12	○	—
—	○	○	10R22.5F	12	○	—
—	○	○	10R22.5G	14	○	—
—	○	○	11R22.5G	14	○	○
—	●	●	11R22.5H	16	○	○
—	○	○	235/80R22.5G	14	○	—
—	○	○	255/70R22.5H	16	○	—
—	○	○	255/80R22.5G	14	○	○
—	○	○	275/70R22.5H	16	○	○
—	○	○	275/70R22.5J	18	○	○
—	○	○	275/80R22.5G	14	○	○
—	○	○	295/75R22.5G	14	○	○
—	○	○	295/80R22.5H	16	○	○

\*NOTE: Due to industry-wide tire availability shortages, tire substitutions may be required at time of vehicle production.

FORD  
LCF

MASSIVE TRANSIT

# RIGHT ON TARGET

Ford LCF is designed and built specifically for the North American market. Its chassis shares key components with our proven Super Duty® models. And it's assembled nearby, not shipped from overseas. All of which means that we can deliver the right vehicle to meet your company's needs, right when you need it.



## LIMITED-SLIP REAR DIFFERENTIAL



For the extra confidence of more rear traction when you need it, choose the optional Truetrac® limited-slip rear differential.

This heavy-duty torque-sensitive unit aids traction by automatically transferring power to the wheel with the most grip. Truetrac's patented helical gear design is maintenance-free and requires no special lubricants.

## BEST-IN-CLASS<sup>1</sup>

### TURNING RADIUS

You'll really appreciate how easy it is to navigate Ford LCF up to loading docks and around crowded job sites. It's all thanks to the superb maneuverability provided by the segment's tightest curb-to-curb turning radius. Ford LCF also features a remarkably short 63.3" bumper-to-back-of-cab (BBC) measurement. The steering system also contributes, with engineering that delivers high-efficiency turn-in. So Ford LCF makes tight corners and fits into small spaces that leave other trucks double-parked.



16'7"  
Turning Radius

WHEELBASE	CURB-TO-CURB	WALL-TO-WALL
115"	16'7"	18'7"
137"	19'3"	21'0"
149"	20'8"	22'5"
167"	22'5"	24'2"
185"	24'6"	26'3"

<sup>1</sup>Class 4 Tilt-Cab Diesels, excluding Ford joint-venture partners.



## EASY TO BUILD

Put together the Ford LCF that fits your business best. A huge array of upfit bodies and equipment can fit on 5 available clean CA (cab-to-axle) measurements. Some competitors' CA specs imply that you have more space than you can use. Ours represent a truly clean, usable part of the frame.

You get quick turnaround on special orders, a feature that competitors who build and customize offshore can't offer. We even cover you with 24-hour turnaround on uptime-critical parts, as well as a unique Limited Warranty<sup>1</sup> through over 700 Ford LCF-Certified Truck Dealers. For true flexibility, versatility and responsiveness to your needs, Ford LCF has the right answer: can do.



**34"**  
FRAME RAIL WIDTH

## LOWER COSTS

A revised maintenance schedule extends the recommended oil, oil filter, fuel filter, power steering fluid, rear axle fluid and automatic transmission fluid changes.<sup>1</sup> The reduced downtime for maintenance means lower cost of ownership for you.

<sup>1</sup>See your dealer for details.

## MORE OF WHAT YOU'RE LOOKING FOR

The low 30" ground-to-top-of-frame height of the Ford LCF standard kickup frame is ideally suited to applications that require a low, flat loadfloor. Ford LCF also features a 34" frame rail width to facilitate upfits. Several fuel tank options include the standard 40-gallon tank mounted aft-of-axle for enhanced weight distribution, or an available 35-gallon tank mounted outside the frame rails on the left. If your upfit dictates, or you need maximum fuel range, opt for two 35-gallon tanks, one mounted on either side of the vehicle. Ford LCF also features 2 maintenance-free batteries conveniently mounted in a box outside the frame rails on the right.

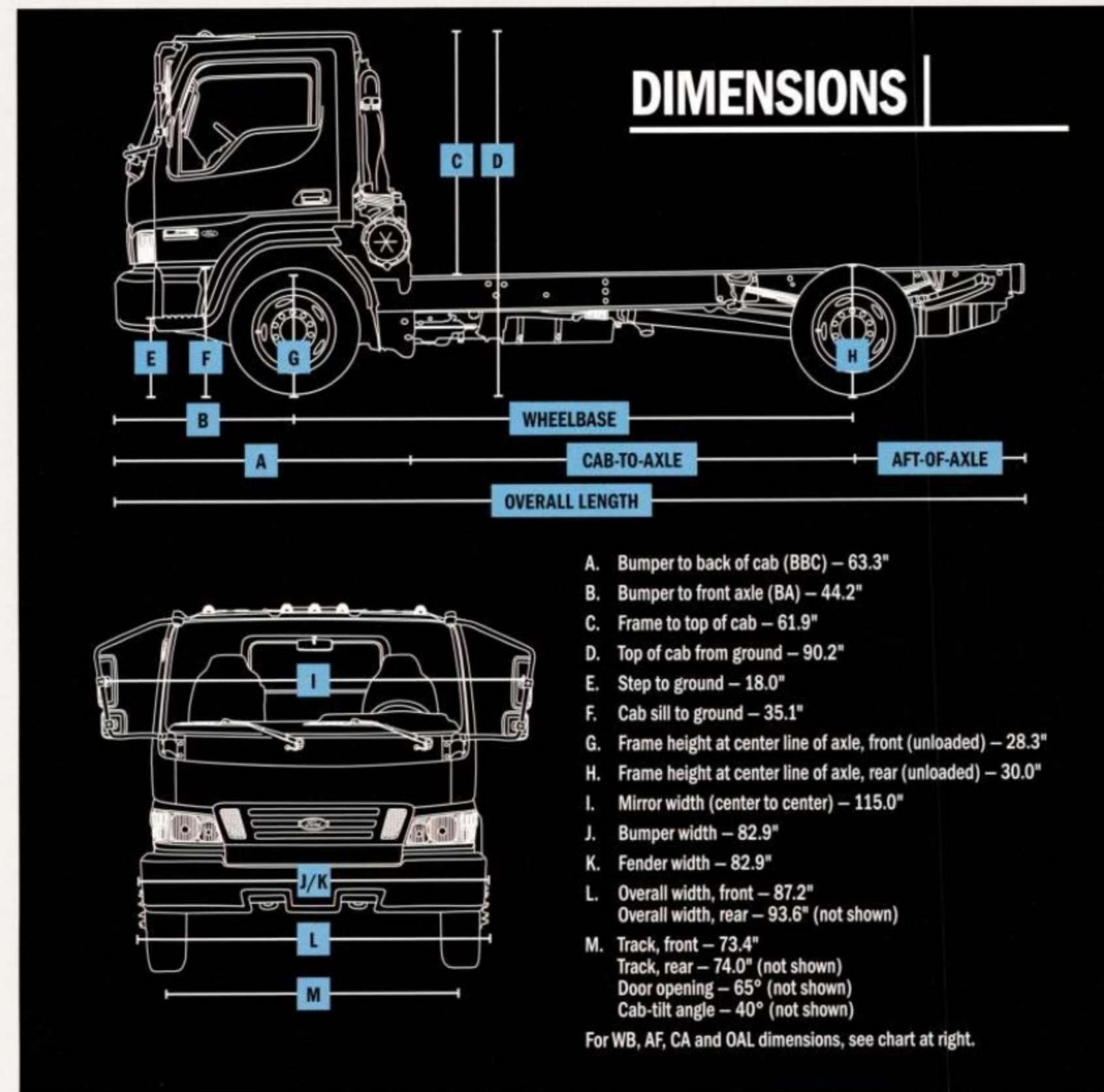
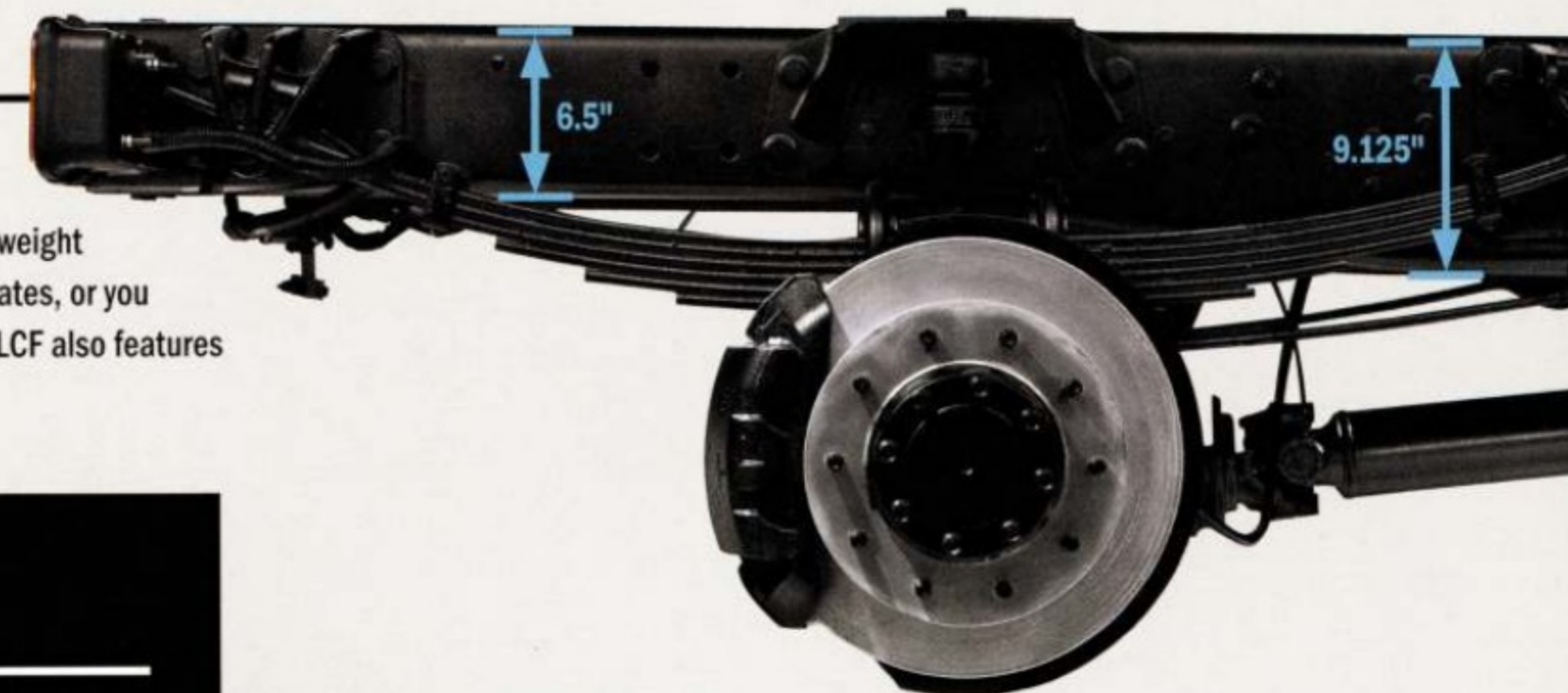

CHASSIS	WHEELBASE (in.) (WB)	AFT-OF-AXLE (in.) (AF)	CAB-TO-AXLE (in.) (CA)	OVERALL LENGTH (in.) (OAL)
<b>CLASS 4 MODEL:</b>				
L45	115	47.5	86	204.7
<b>FRAME RATING:</b>				
50,000 PSI	137	47.5	108	228.7
<b>RBM:</b>				
461,000 IN.-LBS.	149	47.5	120	240.7
	149	75	120	268.2
	167	75	138	286.2
<b>CLASS 5 MODEL:</b>				
L55	115	47.5	86	204.7
	115	63	86	220.2
<b>FRAME RATING:</b>				
50,000 PSI	137	47.5	108	228.7
	137	63	108	244.2
<b>RBM:</b>				
461,000 IN.-LBS.	149	47.5	120	240.7
	149	75	120	268.2
	167	75	138	286.2
	185	96	156	325.2

FORD  
LCF

WORK COMFORTABLY

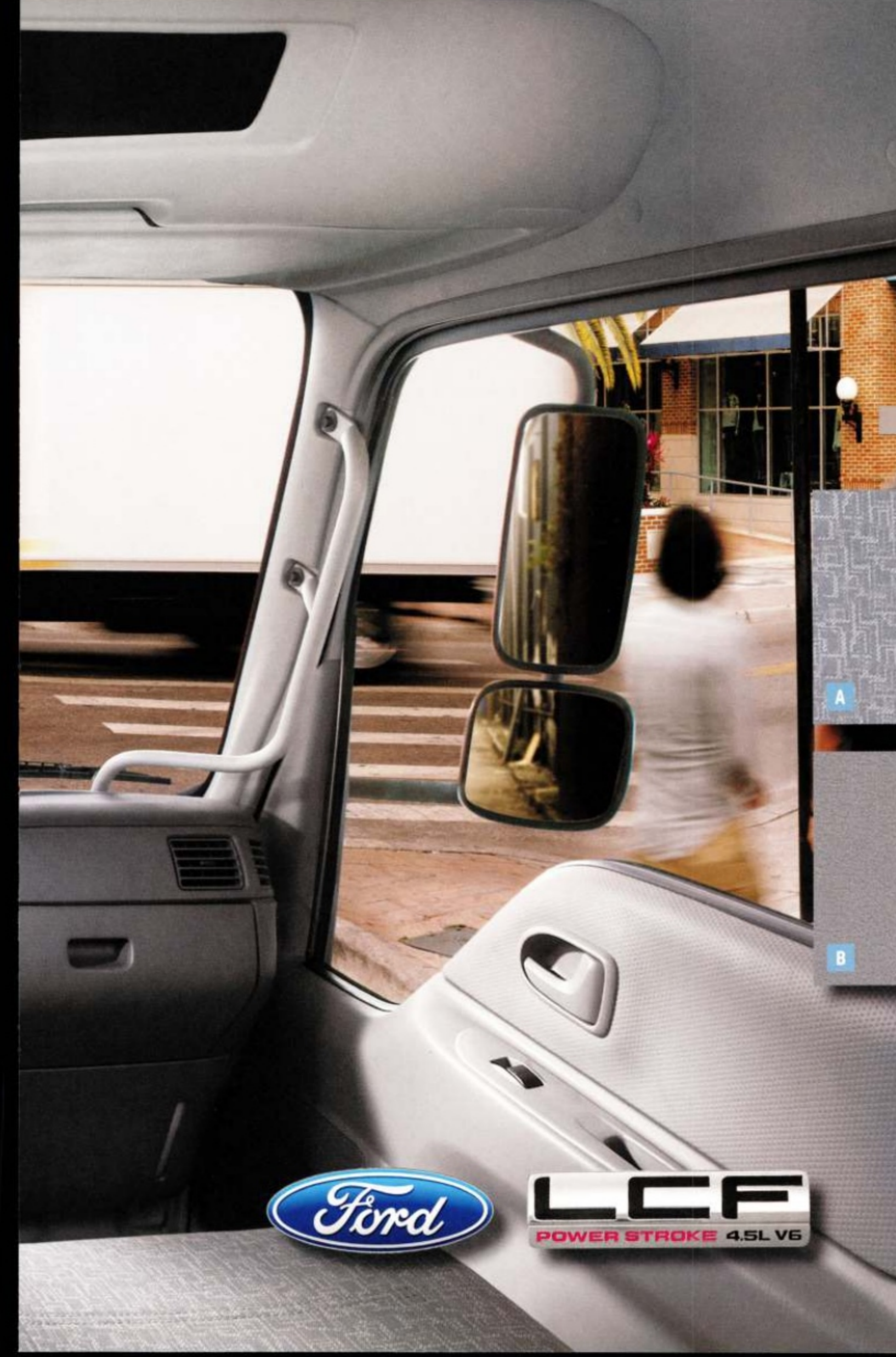

# A CLEAN DESIGN

This good-looking cabin has comfortable standard cloth upholstery, making Ford LCF one very accommodating work truck. Its 3-passenger seating boasts plenty of head and leg room. Plus, the well-positioned grab handles and a low first step make entry and exit easy. Ford LCF can help you get the most out of every workday.

## INTERIORS FOR 2009

Flint Grey Cloth **A** is the standard seating surface on both Ford LCF models. Flint Grey Vinyl **B** is available on both models as a Cloth Delete Option. Standard power door locks and power windows with a one-touch-down driver-window feature add convenience. For extra comfort, choose available air conditioning with integral heater/defroster.



## WHEELS

**C** Standard: 19.5" x 6" hub-piloted, 10-lug white painted-steel with 225/70R19.5 Hankook tires.

**D** Available: 19.5" x 6" hub-piloted, 10-lug polished-aluminum. Also available: Goodyear® and Michelin tires.



## THE HORSEPOWER AND TORQUE YOU'VE COME TO EXPECT

Ford LCF is powered by a 50-State Emissions, clean-diesel package. This rugged engine is combined with Ford's toughest transmission: the TorqShift® 5-speed automatic. Serious power and reliability are yours with Ford LCF.

### 4.5L POWER STROKE® V6 TURBO DIESEL

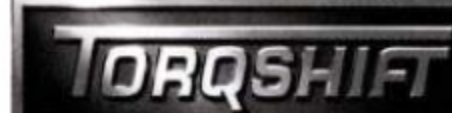

## FORD'S MOST RUGGED TRANSMISSION

The TorqShift 5-speed automatic sets the standard for performance on Super Duty® Pickups and Chassis Cabs. No wonder it's standard on every Ford LCF. Pure electronic shift controls deliver optimum responsiveness, while the torque converter design offers great low-speed capability. Select Tow/Haul Mode when hauling a heavy load or towing a trailer. It helps reduce gear hunting, improves power delivery, and even uses engine braking to help control vehicle speed when descending hills. The available transmission-integrated Power TakeOff (PTO) provision is essential for powering accessories like liftgates, skylifts, auxiliary hydraulic pumps and other add-on equipment. A high-efficiency sump filter allows transmission service interval of up to 60,000 miles.

## READY TO STAND THE TEST

Now in its fourth year of production, the 4.5L Power Stroke V6 has a proven record of reliability, designed to handle everything from brutal city stop-and-go to desert heat and high elevations. The only V6 diesel available in the segment, it features a dual-stage turbo design for quick engine response. This engine also helps make Ford LCF easy to service. The oil and fuel filters are mounted on top of the engine (shown below), so they're readily accessible. And Ford's coast-to-coast network of Ford LCF-Certified Dealers offers quick parts availability.

MAXIMUM RATED HORSEPOWER	200 @ 2700 rpm
MAXIMUM PEAK TORQUE	440 lb.-ft. @ 1800 rpm
COMPRESSION RATIO	18.0:1



## STANDARD EQUIPMENT

### MECHANICAL

Engine – 4.5L Power Stroke V6 Turbo Diesel  
Transmission – TorqShift 5-speed automatic with Tow/Haul Mode  
Air cleaner – Single-element with Filter Minder® indicator  
Alternator – 12-volt, 135-amp  
Batteries – Dual, Motorcraft® 12-volt; 1800 CCA total  
Brakes – Front/rear disc, hydraulic split system with 3-channel Anti-lock Brake System (ABS)  
Cruise control  
Emissions – 50-State certified  
Shock absorbers – Front  
Springs – Auxiliary rear, 1500-lb. rating  
Stabilizer bar – Front  
Steering – Power, Ross TAS37

### EXTERIOR

Cab steps – Integrated into wheel lip  
Clearance lamps – 5 roof-mounted  
Doors – With drop window and black handle  
Grille – Dark Shadow Grey  
Headlamps – Jeweled-appearance  
Mirrors – Dual sideview 6" x 11" rectangular, and 8" x 6" convex rectangular with breakaway-type brackets; 102"-wide spacing  
Tow hooks – 2 front  
Wipers – Fixed and interval settings with wet-arm washer fluid delivery

### INTERIOR

Cupholders – 2 integrated into instrument panel  
Dome light – Door-operated or manual switch  
Door trim – With map pockets (1 per door)  
Floor covering – Vinyl  
Grab handles – Driver and passenger A-pillar-mounted  
Headliner – Color-coordinated cloth  
Heater – With defroster and 4-speed blower motor  
Horn – Electric  
Instrument panel – Color-coordinated with 3 glove compartments, 2 storage bins, air registers, left-hand and center ashtrays, and cigar lighter  
Instrumentation – Tachometer, trip odometer, fuel gauge, coolant temperature gauge and indicator lights  
Mirror – Rearview  
Overhead storage – Full-length, 3-bin  
Power door locks and power windows with one-touch-down driver-window feature  
Power point – Right-side, located below instrument panel  
Safety belts¹ – 3-point (driver and outboard-passenger) and lap belt (center)  
Scuff plates – Color-coordinated with interior trim  
Seat – Driver tilt, high-back cloth with integrated head restraint  
Seat – Center-passenger high-back cloth with integrated head restraint and folding seatback with notebook tray and 2 cupholders  
Seat – Outboard-passenger high-back cloth with integrated head restraint and folding seatback  
Steering column – Tilting and telescoping  
Steering wheel – 16" diameter  
Sun visors – Vinyl with driver-side strap  
Transmission shift control – Floor-mounted with button for Tow/Haul Mode

¹Always wear your safety belt.

## FEATURES & OPTIONS

### L45

### L55

### MECHANICAL

- — Axle, front – Dana Spicer® 6000-lb. I-Beam-type
- ● Axle, front – Dana Spicer 7000-lb. I-Beam-type²
- — Axle, rear – 11,000-lb. single-reduction
- ● Axle, rear – Dana Spicer 13,500-lb. single-reduction³
- ○ CARB-compliant tamper-proof engine idle shutdown
- ○ Engine block heater
- ● Fuel tank – 40-gallon capacity steel, mounted between frame rails, aft-of-rear axle
- ○ Fuel tank – 35-gallon capacity steel, rectangular, mounted to left side of frame⁴
- ○ Fuel tank – Dual 35-gallon capacity steel (70-gallon total capacity), rectangular, mounted to left and right sides of frame⁴
- — GVWR – 16,000-lb.
- — GVWR – 15,000-lb.
- ● GVWR – 19,500-lb.
- ○ GVWR – 17,999-lb.
- ○ Limited-slip rear differential – Eaton's Truetrac®
- ○ PTO (Power TakeOff) provision – Opening on left side of transmission
- ○ Shock absorbers – Rear
- — Springs, front – 6000-lb. tapered leaf
- ● Springs, front – 7000-lb. tapered leaf⁵
- — Springs, rear – 11,000-lb. single variable-rate
- ● Springs, rear – 13,500-lb. single variable-rate⁶
- ○ Tires – 225/70R19.5 Goodyear® G647RSS, load-range F (6)
- ○ Tires – 225/70R19.5 Michelin XZE, load-range F (6)
- ● Tires – 225/70R19.5 Hankook AH 11 (6)
- ○ Tires – 225/70R19.5 Hankook DH 01, rear traction (4)
- ● Wheels – 19.5" x 6" hub-piloted, 10-lug, white painted-steel (6)
- ○ Wheels – 19.5" x 6" hub-piloted, 10-lug, polished-aluminum (6)

### EXTERIOR

- ○ Backup alarm
- ○ Chrome Package – Includes chrome grille and front bumper, and tow hook delete
- ○ Daytime running lamps
- ○ License plate bracket (requires Chrome Package)
- ○ Taillamps delete

### INTERIOR

- ○ Air conditioning
- ● AM/FM stereo with clock
- ○ AM/FM stereo/single-CD player with MP3/satellite capabilities and clock
- ○ Power windows and door locks delete
- ○ Radio Prep Package – Includes wiring and antenna with multiple dual-cone speakers; radio not included
- ○ Vinyl-covered seating

● Standard ○ Optional — Not Available

²Requires 7000-lb. front springs.

³Requires 13,500-lb. rear springs.

⁴Not available with 115" wheelbase.

⁵Requires 7000-lb. front axle.

⁶Requires 13,500-lb. rear axle.

## HEAVY-DUTY FEATURES FOR SUPER DUTY® WORKLOADS



### OUTSTANDING POWER & TORQUE

- Cummins® ISB or Caterpillar® C7 turbo diesels with 17 horsepower/torque ratings
- High-horsepower/medium-torque Cummins available with standard automatic transmission

### CAPABLE WORK TRUCKS

- Clean CA packages
- High Pressure Brakes (HPB) with Quadraulic™ 4-piston calipers
- Exhaust brake options
- Large engine cooling system

### AND MORE

- Standard 13,500-lb. rear axle rating; available 15,500-lb. and 17,500-lb. rear axle ratings on F-650 Pro Loader®
- Available 14,000-lb. front axle rating and parabolic front springs on F-750
- Standard 130-amp alternator; 130-, 160-, 200- and 270-amp optional on select models
- 45- to 145-gallon fuel capacity offerings

## EXTERIOR COLORS



- |                      |                |
|----------------------|----------------|
| 1 Black              | 5 Oxford White |
| 2 School Bus Yellow  | 6 Winter White |
| 3 Bright Red         | 7 Omaha Orange |
| 4 True Blue Metallic | 8 Bold Yellow  |
|                      | 9 Holly Green  |

Comparisons based on 2008 competitive models (F-650/F-750: Class 6 and 7 Chassis Cabs; Ford LCF: Class 4 Tilt-Cab Diesels), publicly available information and Ford certification data at time of printing. Some features discussed may be optional. Vehicles shown may contain optional and aftermarket uplift equipment. Features shown may be offered only in combination with other options or subject to additional ordering requirements or limitations. Dimensions and capacity ratings shown may vary due to optional features and/or production variability. Following publication of the catalog, certain changes in standard equipment, options and the like, or product delays may have occurred which would not be included in these pages. Your Ford Dealer is the best source for up-to-date information. Ford Division reserves the right to change product specifications at any time without incurring obligations. Body manufacturers are responsible for compliance certification of the completed vehicle. The Ford New Vehicle Limited Warranty and any government certification made by Ford shall cover only the vehicle as manufactured by Ford and shall not extend to any addition, modification or change of or to the vehicle by the Ford Authorized Pool Account.

## BEST-IN-CLASS TURNING RADIUS

## UNSURPASSED FRAME STRENGTH (RBM)

### OUTSTANDING POWER & TORQUE

- 4.5L Power Stroke® V6 Turbo Diesel
- 200 horsepower and 440 lb.-ft. of torque
- Ford Clean Diesel Technology™

### CAPABLE WORK TRUCKS

- 4 GVWR offerings: 15,000 and 16,000 lbs. (L45); 17,999 and 19,500 lbs. (L55)
- 4-wheel disc brakes with ABS
- Class-exclusive Huck Bolt™ frame construction
- 19.5" wheels and tires

### NO-CHARGE EXTRAS

- 9 exterior color choices
- Power windows and door locks
- Cloth or vinyl interior trim



## EXTERIOR COLORS

- |                      |                |
|----------------------|----------------|
| 1 Black              | 5 Oxford White |
| 2 School Bus Yellow  | 6 Winter White |
| 3 Bright Red         | 7 Omaha Orange |
| 4 True Blue Metallic | 8 Bold Yellow  |
|                      | 9 Holly Green  |



Ford uses clearcoat paint for beauty and protection. Colors shown are representative only. Not all colors are available on all models. See your dealer for actual paint/trim options.

### QUALITY TRUCKS.

F-Series trucks have a reputation for quality that has made them America's best-selling line of trucks for 31 years in a row.



### GREEN TRUCKS.

Ford Clean Diesel Technology™ and Ultra-Low-Sulfur Diesel help keep our diesel emissions in compliance with stringent regulations.



### SAFE TRUCKS.

New Meritor® Quadraulic™ disc brakes on F-650 and F-750 provide outstanding stopping power, as well as Traction Control and ABS.



### SMART TRUCKS.

From Business Preferred Network services to truck features that help boost productivity, Ford is the smart choice.



To learn more, visit  
[commtruck.ford.com](http://commtruck.ford.com)