



1995
CHRYSLER-PLYMOUTH
FULL LINE



CONTENTS

CIRRUS

Cab-forward engineering has created a new generation of sports sedan 3

CONCORDE

The car that changed the architecture of the automobile..... 6

LHS

The performance, engineering and quality of a European road car 8

NEW YORKER

One of the most eloquent expressions ever of form following function 10

LEBARON CONVERTIBLE

All the fun of top-down driving, at an affordable price..... 12

TOWN & COUNTRY

The ultimate in minivan luxury, safety and engineering..... 13

NEON

The hot new benchmark in small cars, available in two- or four-door models 14

VOYAGER

America's first and foremost minivan is still affordable ... 16

GRAND VOYAGER

All the advantages of Voyager in a longer, roomier model..... 18

ACCLAIM

One of America's most affordable six-passenger sedans 20

PROWLER

Plymouth's streetwise concept car..... 20

SAFETY 21

ENGINEERING ... 22

CHRYSLER: LEADERSHIP BY DESIGN



Chrysler's automotive architects subscribe to the theory that form best follows function, a belief that has elevated Chrysler to a position of automotive design leadership.

This design leadership is well evidenced by the 1995 Cirrus, Concorde, New Yorker, LHS, Town & Country and LeBaron Convertible, all of which are described in the Chrysler section of this brochure.

Like all new Chrysler vehicles, these cars derive from a heritage of over 70 years of engineering expertise and innovative thinking. It is no coincidence that 1995 has been chosen as the year to reintroduce the emblem that for so many years symbolized Chrysler's legendary quality.

PLYMOUTH: LEADERSHIP BY INNOVATION



The innovation began in 1928 with the Model Q. And ever since, the Plymouth name has symbolized fun-to-drive value. No fewer than five million current Plymouth owners can attest to that. And the 1995 Plymouths are no exception. Within the Plymouth pages of this brochure, you'll say hello to the charming Plymouth Neon. You'll also read about America's unmatched minivans, the Plymouth Voyager and Grand Voyager. And you'll get acquainted with Plymouth Acclaim, one of the most affordable six-passenger cars in America.

You'll even have an opportunity to preview the streetwise Prowler concept car — further proof that Plymouth's reputation for unceasing innovation remains intact.

CIRRUS





IT'S NOT JUST A STEP ABOVE, IT'S THE NEW PLATEAU. The all-new Chrysler Cirrus offers styling reminiscent of a sporty coupe; handling evocative of that coupe's performance; and an astonishing array of luxo-sporty standard extras. With the Chrysler Cirrus, the third generation of cab-forward engineering. Chrysler definitively owns the rights to functional luxury. But in this case, cab-forward engineering establishes the perfect architecture for a sporty sedan. Cirrus' wheels-toward-the-corners design allows an interior cabin area of 95.9 cubic feet, beyond expectations for many compact-classed automobiles. The wider stance it creates also improves stability and expands interior hip and shoulder room. Cirrus' rail-through construction improves structural rigidity and eliminates the need for extra ribs and supports, reducing weight and minimizing rattle-prone joints. The modified double-wishbone suspension system allows ride and handling characteristics to be tuned independently, satisfying the driver's demand for responsive handling and the passenger's desire for smooth sailing.



CIRRUS



Large numerals on gauges are easy to read. Available leather-trimmed interior and eight-way power driver's seat shown at left.



CHRYSLER CONCORDE. THE CAR THAT CHANGED THE ARCHITECTURE OF THE AUTOMOBILE. Concorde's innovative cab-forward design has forever altered the very architecture of the midsize sedan. Concorde's introduction was greeted by an unsurpassed rush of awards. Its comfort, room, full equipment and affordable price continue to win it accolades. Cab-forward architecture gives the car a wide track for precise handling and an immense interior, leaving you lots of room for available luxury appointments such as a power moonroof,* CD player and leather-trimmed seats. Safety features such as dual air bags,† four-wheel disc antilock brakes and dynamic side-impact protection are standard. Let Concorde show you the advantages of form and function.

*Late availability.
†Always wear your seat belts.



CONCORDE



Wide-opening, easy-loading trunk can hold 16.6 cubic feet of luggage. An interior with leather trim (left) is available on Concorde.



PRESENTING THE CHRYSLER LHS. ITS FUNCTION? TO PERFORM. The Chrysler LHS was designed from the ground up to let owners experience and enjoy the act of driving. Four-wheel fully independent suspension allows you to straighten tight hairpins with authority. And a 24-valve, 214-horsepower V6 engine satisfies your urge for power. Cab-forward interior design is what boosts the LHS to the forefront of the luxury class. All safety, comfort and convenience features are standard. Our top-of-the-line Chrysler LHS establishes benchmarks by which other personal/luxury sedans will be gauged in the future.



An interior (far left) with leather trim is standard on LHS. Power moonroof shown (top) is late availability.

LHS



CHRYSLER NEW YORKER. ONE OF THE MOST ELOQUENT EXPRESSIONS EVER OF FORM FOLLOWING FUNCTION.

Its luxury is driven by technology to achieve a unique fusion of traditional six-passenger comfort and well-balanced performance. Four-wheel independent suspension with gas-charged struts make the handling control exemplary. Dual air bags,* four-wheel disc antilock brakes, and a 24-valve, 214-horsepower V6 engine are standard. Even the steeply raked windshield dramatically aids aerodynamics, adds to the car's astonishing visibility, and helps make the interior free of wind noise. And you'll find abundant room in New Yorker's award-winning cab-forward design.

* Always wear your seat belts.



NEW YORKER



The available Automatic Temperature Control system circulates air throughout the passenger cabin. Leather-trimmed interior (left) is available on New Yorker.



CHRYSLER LEBARON CONVERTIBLE. ALL THE FUN OF TOP-DOWN DRIVING, ALL THE SUBSTANCE OF A FULLY EQUIPPED HARDTOP — ALL AT AN AFFORDABLE PRICE. If LeBaron GTC Convertible's top-down silhouette and monochromatic appearance don't capture your attention, the acceleration of its standard 141-horsepower 3.0-liter V6 engine* will. To help tame all this power, LeBaron Convertible offers available four-wheel disc antilock brakes, plus the safety of standard driver and front-passenger air bags! Outstanding structural integrity improves the ride and reduces wind noise. Inside, LeBaron Convertible's wraparound instrument panel is a blueprint of ergonomic design. Available premium leather-trimmed seats and a six-way power driver's seat add to the luxurious accommodations.

*Built by Mitsubishi Motors Corporation.
 †Always wear your seat belts.



Available premium leather-trimmed seating.

LEBARON CONVERTIBLE



CHRYSLER TOWN & COUNTRY. THE ULTIMATE IN LUXURY, SAFETY AND ENGINEERING. Here is a minivan that knows its place. Chrysler Town & Country fits in perfectly *anywhere* from the poshest of resorts to the mightiest of malls. The Chrysler Town & Country's form is a perfect reflection of its function — to deliver what may well be the highest level of luxury, comfort, convenience and safety available in any minivan. Standard features include a powerful 3.8-liter V6 engine, driver and front-passenger air bags,* four-wheel antilock brakes and seven-passenger seating with leather trim. Integrated Child Safety Seats, which recline for greater sleeping comfort, are optional.

*Always wear your seat belts.

THE MINIVAN STORE™



TOWN & COUNTRY



Standard driver and front-passenger air bags.*
 Standard leather-trimmed seating (above).

Plymouth Neon

Whether you choose the totally awesome coupe or the fun-loving sedan, Plymouth Neon is definitely a gas. Neon's radical cab-forward architecture creates tons of room for five adults.

Outside, Neon deftly cheats the wind like an F-16 fighter jet. A fully independent four-wheel suspension empowers both coupe and sedan to race along straightaways and handle curves like an Indy car.

Inside, Neon's wraparound cockpit traces its roots to ergonomic studies pioneered by the U.S. Air Force. Switches and buttons impart a precision feel and are easy to operate, even with gloved fingers. Driver and front-passenger air bags* are standard, and a foldaway Integrated Child Safety Seat is available. The 60/40 split rear seatbacks[†] on Neon Sport and Highline can be folded forward individually or in tandem when carrying large loads.



*Always wear your seat belts.
[†]Not available with Integrated Child Safety Seat.



Plymouth Voyager



It's a family affair. Plymouth Voyager minivans are a household name and a top choice for all kinds of families on the go. Kids, especially, love riding in a Voyager because it's lots of fun to see everything from all angles.

THE MINIVAN STORE®



Voyager with available Family Value Package

Fun for the entire family, Plymouth Voyager SE (above) is the result of progressive engineering designed specifically to provide car-like comfort and handling, not to mention the cargo-carrying ability and superior seating capacity found in larger vehicles.

Equally important are Voyager SE's equipment features: a responsive 3.0-liter SMPI V6 engine* with a three-speed automatic transaxle or an available four-speed overdrive automatic; 3.3-liter V6 engine availability for more power on demand; adaptable seven-passenger seating; electronic speed control; dual power exterior rearview mirrors; tilt steering column; and a six-speaker AM/FM stereo radio with

cassette. Add available four-wheel antilock brakes for a good measure of safety that can be especially useful when stopping on slippery surfaces.

The value-packed base model Voyager (left) has been a success with families due to its great all-around capabilities. *It's one of the best values you can get in a minivan today.* For sensational savings on equipment extras, add the optional Family Value Package! It provides numerous conveniences, including a three-speed automatic, air conditioning, locking underseat storage drawer, bodyside molding and map/cargo lamps.

*Built by Mitsubishi Motors Corporation.
†Savings on option package and no-charge air conditioning based on cost of package items if purchased separately.

Plymouth Grand Voyager



Safety on a grand scale. Plymouth Grand Voyager LE watches over you and your loved ones with sterling safety credentials that speak for themselves: driver and front-passenger air bags; antilock brakes; high-strength steel side-guard door beams that meet 1997 federal dynamic side-impact protection requirements; front-wheel drive or optional all-wheel drive; dual power heated rearview mirrors; electric rear window defroster and available Integrated Child Safety Seats. You can trust Grand Voyager to treat your family right.

*Always wear your seat belts.

THE MINIVAN STORE



Grand Voyager SE with available Rallye Package

From toting one-of-a-kind art finds to transporting the victorious soccer team, Plymouth Grand Voyager handles the load as well as fun times on the road. Sizable versatility makes it perfect for any transit application. And Grand Voyager helps you go about your business with car-like maneuverability. The LE (above) is the top of the line in Grand Voyager models and comes equipped with an extra-spacious seven-passenger interior, standard four-wheel antilock brakes, a 3.3-liter V6 engine that delivers an upgraded output of 162 horsepower, a smooth-operating four-speed automatic transaxle, air

conditioning that utilizes environmentally correct non-CFC refrigerant, and power rear quarter vent windows.

Plymouth Grand Voyager SE and LE come in all-wheel-drive versions for greater go-anywhere travel. For more power, a high-torque 3.8-liter V6 engine is available on Grand Voyager LE. Plus, the new available Rallye Package (left) allows you to tailor your SE to your exacting taste, with features such as 15-inch silver accent cast aluminum wheels, sunscreen glass, special badging and lower body two-tone Driftwood paint treatment.

Plymouth Acclaim

Designed with an eye toward even the smallest details, Plymouth Acclaim delivers the features and qualities drivers want most in a midsize sedan: six-passenger seating, available V6 power,* impressive handling, outstanding roominess, contemporary styling, and a long list of value-added standard features. All of this makes the 1995 Acclaim one of the best-equipped, lowest-priced* six-passenger cars in America today.

Acclaim puts all controls at your fingertips for maximum driver convenience. The ergonomically

designed instrument panel features a luxury steering wheel with driver-side air bag,[†] easy-to-read gauges, electronic speed control, non-CFC refrigerant air conditioning, tilt steering wheel, and AM/FM stereo radio with cassette player.

Created to enhance your driving experience, Plymouth Acclaim is a truly refined family-size sedan that's surprisingly roomy, comfortable and affordable.

*Built by Mitsubishi Motors Corporation.
[†]Based on MSRP. Excludes tax, title and destination charges.
[‡]Always wear your seat belts.



Plymouth Prowler



One look at the Plymouth Prowler concept car and you can see why it draws more than its fair share of "oohs" and "aahs" as it tours the country and makes appearances at select auto shows. Quite simply, this "blast from the past" is one cool cat. Taking its cue from the timeless appeal of '50s street rods, Prowler was created with many upgraded production vehicle features, including a 3.5-liter 24-valve overhead cam V6 engine.

SAFETY



DUAL AIR BAGS.* Every new Chrysler and Plymouth vehicle (except Acclaim) offers the safety of standard driver and front-passenger air bags. Dual capacitors store an electrical charge that deploys the bags even if the vehicle's power system fails. For additional safety, the lower surface of the instrument panel acts as a knee blocker to reduce forward motion of the lower body upon impact.

ANTILOCK BRAKE SYSTEM. A four-wheel antilock system automatically "pumps" the brakes 15 times per second to prevent lockup during severe braking situations. For example: when electronic sensors detect an impending

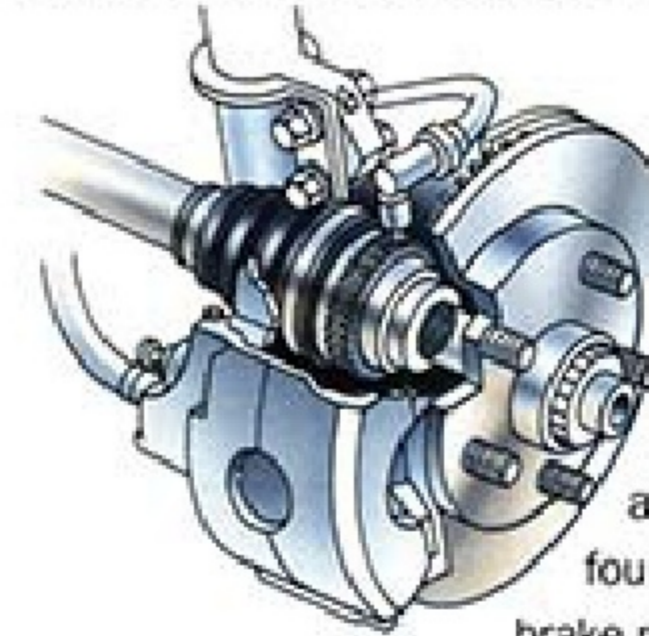

lockup at any of the four wheels, brake pressure to that wheel is reduced. This allows the driver to maintain better control and bring the car to a stop in the shortest distance possible. Standard on Cirrus, Concorde,

New Yorker, LHS and Town & Country. Available on LeBaron Convertible, Voyager/Grand Voyager and Neon.

CHILD SAFETY SEAT. The Integrated Child Safety Seat, optional on Chrysler Cirrus and Concorde as well as Plymouth Neon, folds down from the middle of the rear seat, a position that minimizes the effects of side-impact accidents.



Chrysler Town & Country and Plymouth Voyager/Grand Voyager offer optional dual Integrated Child Safety Seats, with a toddler and a toddler/booster seat built into the middle bench seat. The minivan child safety seats have a two-position recline feature to provide greater comfort for sleeping children.

HIGH-STRENGTH STEEL SIDE-GUARD DOOR BEAMS. Located in all doors on Cirrus, LHS, New Yorker, Concorde, LeBaron Convertible, Neon and Acclaim, as well as in the driver, passenger and sliding side doors on Town & Country and Voyager/Grand Voyager, these standard beams help protect occupants during a lateral impact.

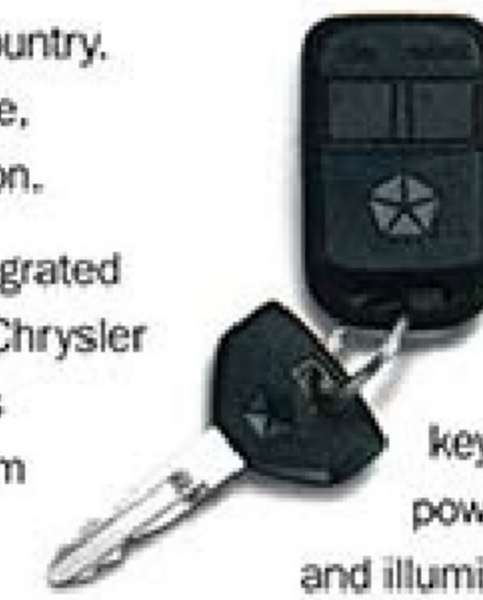

ELECTRONIC VEHICLE SECURITY.

This available dealer-installed alarm system can be armed and disarmed using the remote control, hand-held key fob, which also controls power door locks, trunk release and illuminated entry systems (on cars so equipped).

CELLULAR PHONES! Choose from three Chrysler cellular phones: The portable phone (far right) is compact and lightweight enough to slip into a pocket or purse.

The mobile phone (right) is powered by the vehicle's battery and requires an external antenna.

The trans-portable softpack "bag" phone weighs just 2.2 pounds and is easily moved from car to car.

*Always wear your seat belts.
[†]See back cover for details.



CAB-FORWARD DESIGN

Lower hood and beltline enhance stylish silhouette.

Visibility is clearly improved by the enormous windshield that is sharply angled.

Even trunk space is increased by cab-forward design.



Minimizing the space of the engine compartment allows more room inside for driver and passengers.

Longer wheelbase translates to a smooth ride, and wider rear door openings.

Wider track expands seat width for more hip and shoulder room.



ENGINE. Standard on LHS and New Yorker, and available for Concorde is a 3.5-liter, 24-valve V6. This longitudinally mounted engine turns out 214 horsepower at 5,850 rpm with 221 lb-ft of torque at 3,100 rpm and is calibrated to perform efficiently using mid-grade unleaded fuel. In fact, it can outperform many V8s in its class. Features include sequential multipoint fuel injection (SMPI) and two intake, two exhaust valves per cylinder.

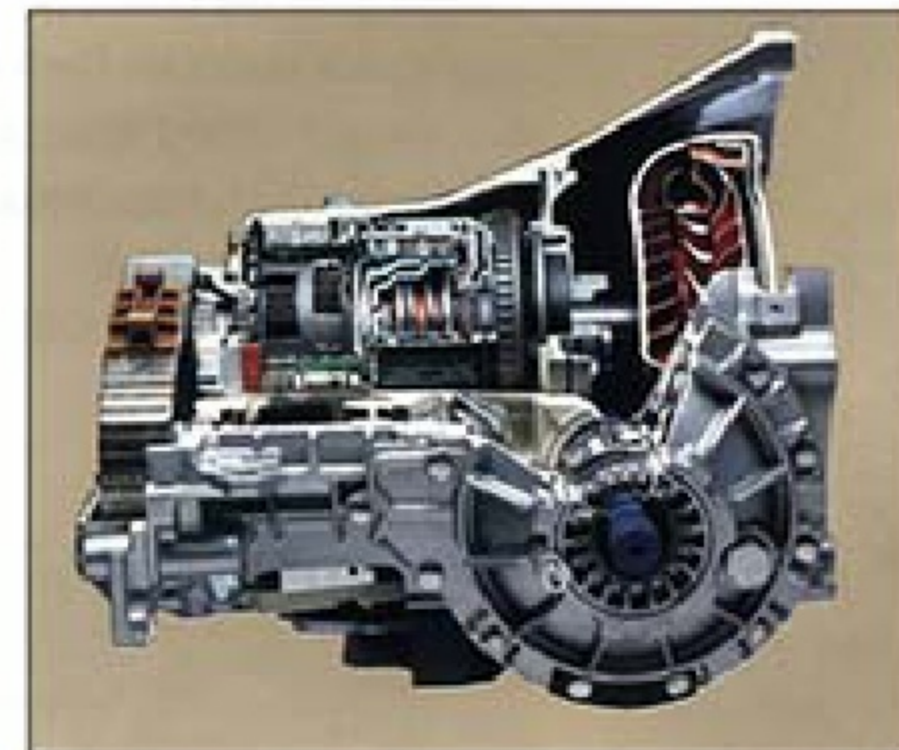

AUTOMATIC TRANSAXLE. This sophisticated four-speed unit is designed and built by Chrysler for compatibility specifically with our longitudinally mounted engines. It features an economy overdrive fourth gear and a fully adaptive electronic control that adjusts accordingly as you drive to optimize shift points.

QUIET CONTROL

Cab-forward design's aerodynamic shape not only helps produce an extremely low coefficient of drag, but it also reduces wind noise. Nor can the wind get in through the steeply raked windshield or the doors which are triple-sealed — twice along the full perimeters of both doors and frame and a third time along the doors above the belt line. Standard on Concorde, New Yorker and LHS.

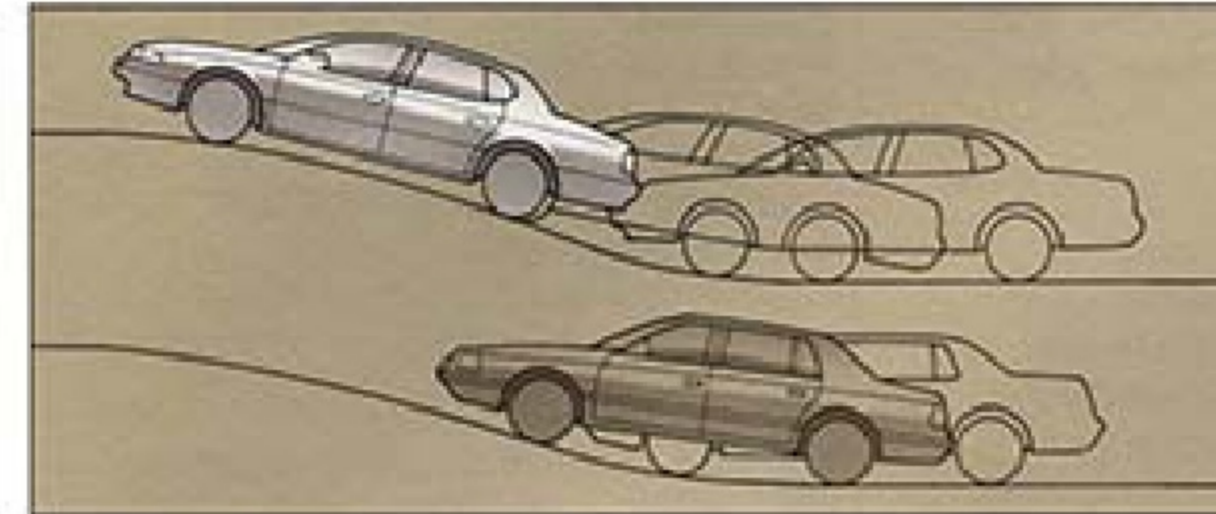

TRACTION CONTROL. In addition to a standard four-wheel antilock braking system,* Chrysler makes traction control available on Concorde and New Yorker models (standard on LHS). This refined system helps prevent the front wheels from spinning on slippery or graveled surfaces at vehicle speeds of 25 mph or less.

SUSPENSION. Standard systems are designed to reduce road harshness and noise as well as provide a smooth ride. On some models we offer performance/touring suspensions that contribute to crisper handling and a "sportier" road response.



STRUCTURE. Structural analysis computer modeling is used extensively to help Chrysler engineers pinpoint, stiffen and strengthen critical body points without adding weight. The goal is to enhance on-the-road comfort and to provide a smooth, quiet ride.

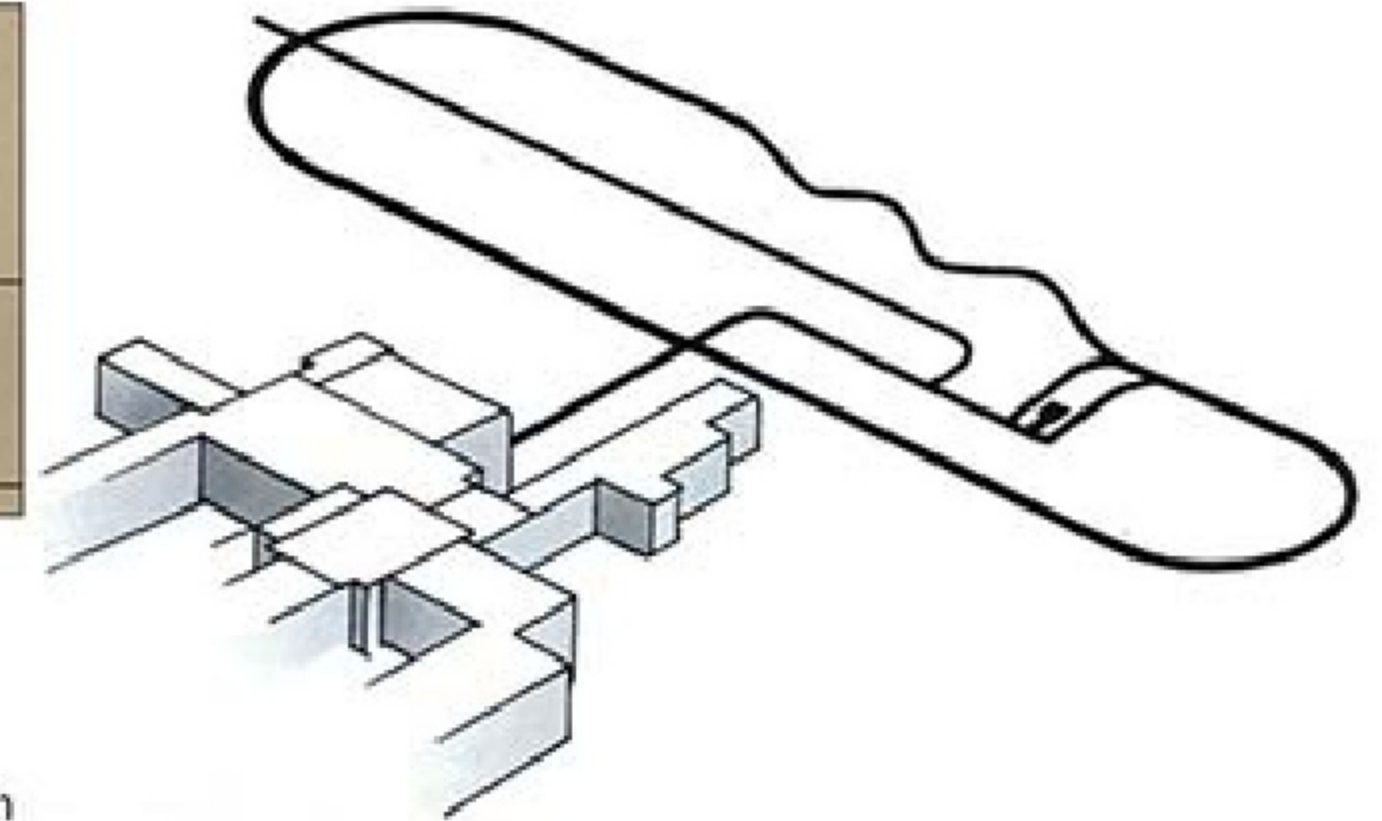

PILOT PLANT. All future Chrysler products will originate at the research and development facilities of the Chrysler Technology Center. At the CTC pilot plant, components such as engines, suspension systems and sheet metal are meticulously checked for any needed modifications. And by building "pilot cars" at this mini assembly plant, the tools to be used in actual production can be perfected and the entire assembly process fine-tuned.



CRUSH ZONES. In the event of a high-speed impact, the front and the rear of Chrysler and Plymouth cab-forward designed cars are constructed to crumple and absorb energy. Front and rear bumpers use ultra-high-strength steel to withstand low-speed mishaps.

*Standard on all Chrysler Division vehicles except LeBaron Convertible.

WHAT ABOUT LEASING?

Leasing continues to grow in popularity — last year one out of every five new vehicles delivered was leased rather than purchased or traditionally financed.

Leasing as an alternative to financing provides a number of benefits. There's no down payment, just a security deposit and the first month's lease payment at delivery. Lower monthly payments are realized because you only pay for the time you actually use your vehicle. Since you choose the terms, leasing can also let you drive a new car more often. And you could move up to a higher-priced vehicle with extra options as well.

Your Chrysler-Plymouth dealer can show you what a lease tailored to your own specifications can do for you. Please ask about Chrysler Corporation's own GOLD KEY PLANS.

CustomerOne Care

3/36 Bumper To Bumper

Chrysler and Plymouth vehicles are covered by the 3/36 Customer One Care Plan,* which includes:

A 3-year or 36,000-mile (whichever comes first) Bumper-to-Bumper Limited Warranty which covers the complete vehicle against defects in factory-supplied materials and workmanship. (This 3/36 warranty excludes tires, wiper blades, clutch and brake linings and normal maintenance items.†)

CustomerOne Care

24 Hour Roadside Assistance

Roadside Assistance for 3 years or 36,000 miles providing 24-hour, 7-day-a-week Emergency Road Service, contacted by a 24-hour nationwide toll-free number. Roadside Assistance covers many items not included in the 3/36 warranty, such as lockout, jump start, out-of-gas, flat-tire repair and towing.‡

A 7-year or 100,000-mile Outer-Panel Rust-Through Limited Warranty which covers the cost of all parts and labor needed to repair exterior sheet-metal panels perforated by corrosion.

The 3/36 Customer One Care Plan stays with the vehicle, and transfers automatically to subsequent owners at no cost during the warranty period.

*See your dealer for details and a copy of this limited warranty. †Tires and optional cellular phones are covered by their own manufacturers' warranty. ‡Roadside Assistance services provided by Cross Country Motor Club, Inc. (in California, Cross Country Motor Club of California, Inc.)

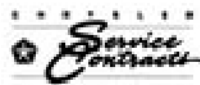

We're Serious About Service

Additional peace-of-mind protection for vehicle owners is available through optional Chrysler Service Contracts. These services are available in a variety of time and mileage combinations to meet your particular driving needs.



Chrysler Credit offers a broad range of traditional automotive financing and flexible terms for qualified buyers. Many of these plans can be customized to fit your particular budget and life-style. Our College Graduate Plans, for example, are especially attractive to those just beginning their careers. Or to make your new vehicle even more affordable, you may want to consider Gold Key Lease and Gold Key Plus short term financing.



CHRYSLER CORPORATION PARTS

Mopar parts are engineered by Chrysler Corporation for use in your new Chrysler or Plymouth vehicle. When replacement is necessary, be sure to specify Mopar parts. Used by professional automotive technicians worldwide.

MOPAR ACCESSORIES

Mopar accessories are available for Chrysler and Plymouth vehicles. See your dealer for a complete list and availability by model.

Mopar's diagnostic service system offers you today's most advanced technical service capability. Technicians use computerized procedures to quickly and accurately service your vehicle.



BUY YOUR CAR PHONE WHERE YOU BUY YOUR CAR. For 1995, Chrysler and Plymouth will be offering a selection of dealer-installed/ supplied cellular phones in several models to enhance the available optional equipment list. Ask your dealer for details. OKI® and Chrysler Cellular Systems warrant and service these products. Restrictions apply. Ask your dealer for details and a copy of these limited warranties.



AUTOMOBILITY PROGRAM (FORMERLY P-CAP)

Cash reimbursement is available for qualified adaptive driving devices on 1995 Chrysler and Plymouth vehicles. Ask your dealer to provide you with more information or call AUTOMOBILITY HEADQUARTERS at 1-800-255-9877.

All product illustrations and specifications are based upon current information at the time of publication approval. Although descriptions are believed correct, complete accuracy cannot be guaranteed. Chrysler Corporation reserves the right to make changes from time to time, without notice or obligation, in prices, specifications, colors and materials, and to change or discontinue models. See your dealer for the latest information.

Chrysler, Mopar, New Yorker, Concorde, Town & Country, Acclaim, LHS, LeBaron, Voyager, Cirrus, Neon and Prowler are trademarks of Chrysler Corporation.

Always wear your seat belts.

CUSTOMER ONE

Futuristic design. Innovative engineering. Quality production. All are embodied in these Chrysler and Plymouth vehicles. But to you, the car buyer, the vast resources of Chrysler Corporation are centered in just one place: the dealership.

To insure that your experience there will be a satisfactory one, more than 100,000 dealership management, sales and service people are participating in the most extensive educational initiative in automotive history.

It's called Customer One and it establishes one unbreakable rule: Treat every customer you meet with honesty and respect.

Customer courtesy and respect is not a goal—it is an imperative. Product knowledge is another essential, and it is imparted to dealership personnel through self-educating training materials which supplement formal product training and driving sessions. Service personnel, too, are trained, not just to provide the technical answer to a problem, but to respond personally to every owner.

That's the new Chrysler culture: new ways to research, create, test and build world-class cars — and improved ways to provide world-class treatment of the people who buy them.