

audiusa.com | audicanada.ca

Note: A word about this brochure. Audi of America, Inc. and Audi Canada believe the specifications in this brochure to be correct at the time of printing. However, specifications, standard equipment, options and colors are subject to change without notice. Some equipment may be unavailable when your vehicle is built. Please ask your dealer for advice concerning current availability of standard and optional equipment and verify that your vehicle will include the equipment you ordered. Vehicles in this brochure are shown with optional equipment. See your dealer for complete details on the limited warranty, Audi 24-hour Roadside Assistance (Coverage provided by Road America in the U.S. and by Professional Dispatch Group, Welland, Ontario in Canada. Certain conditions apply, see your dealer for details.) and 12-year limited warranty against corrosion perforation. Tires supplied by various manufacturers. "Audi," "quattro," "TT," "ASF," "FSI," "MMI," the four rings and Audi emblems are registered trademarks and S tronic is a trademark of Audi AG. "Servotronic" is a registered trademark of the AM General Corporation. "Bose" and "AudioPilot" are registered trademarks of the Bose Corporation. "Bosch" is a registered trademark of Robert Bosch GmbH. "Alcantara" is a registered trademark of Alcantara S.P.A. "ESP" is a registered trademark of DaimlerChrysler AG. "HomeLink" is a registered trademark of Prince Corporation, Holland, Michigan. Prince is a wholly owned subsidiary of Johnson Controls.™ "SIRIUS" is a registered trademark of SIRIUS Satellite Radio, Inc. "Bluetooth" is a registered trademark of Bluetooth SIG. "iPod" is a registered trademark of Apple Computer, Inc.

A word about updated service information. Audi regularly sends its dealers useful service information about its products. Audi monitors product performance in the field, then prepares bulletins to better service its products and help avoid costly repairs. To order, see your local Audi dealer.

©2007 Audi of America, Inc. and Audi Canada

Printed in U.S.A.
C-TT-08-001US



Audi

► The all-new

2008 TT Coupe and Roadster



Generation Next: Longer and wider. Sleeker, stronger and safer.

Beyond pure design, pure performance.



Audi

More than another sports car, the next sports car.

The evolution of an icon:
Daring. Deliberate. And determined to lead.

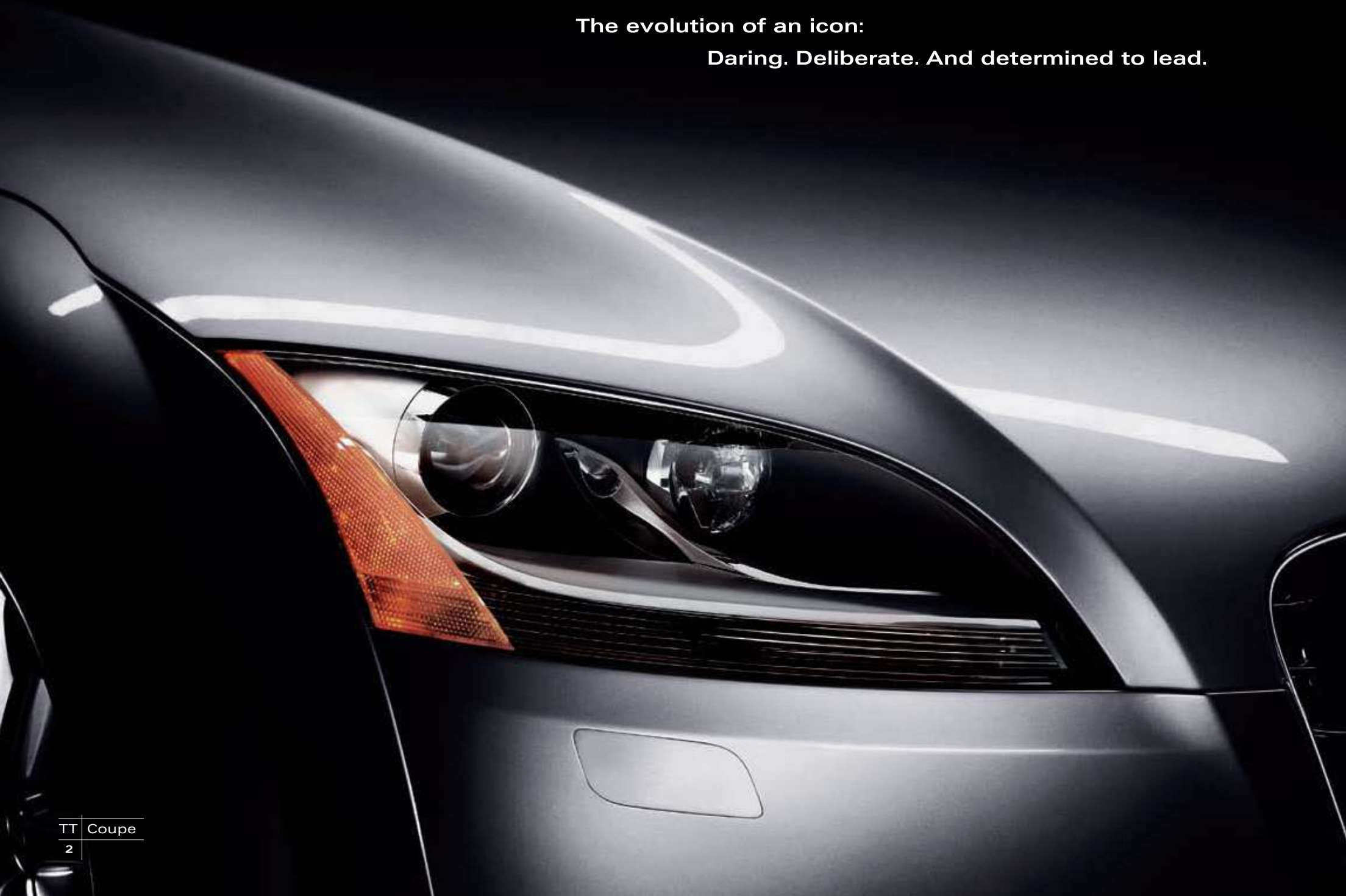



Audi TT 2.0 T Coupe with Premium package and optional equipment shown.

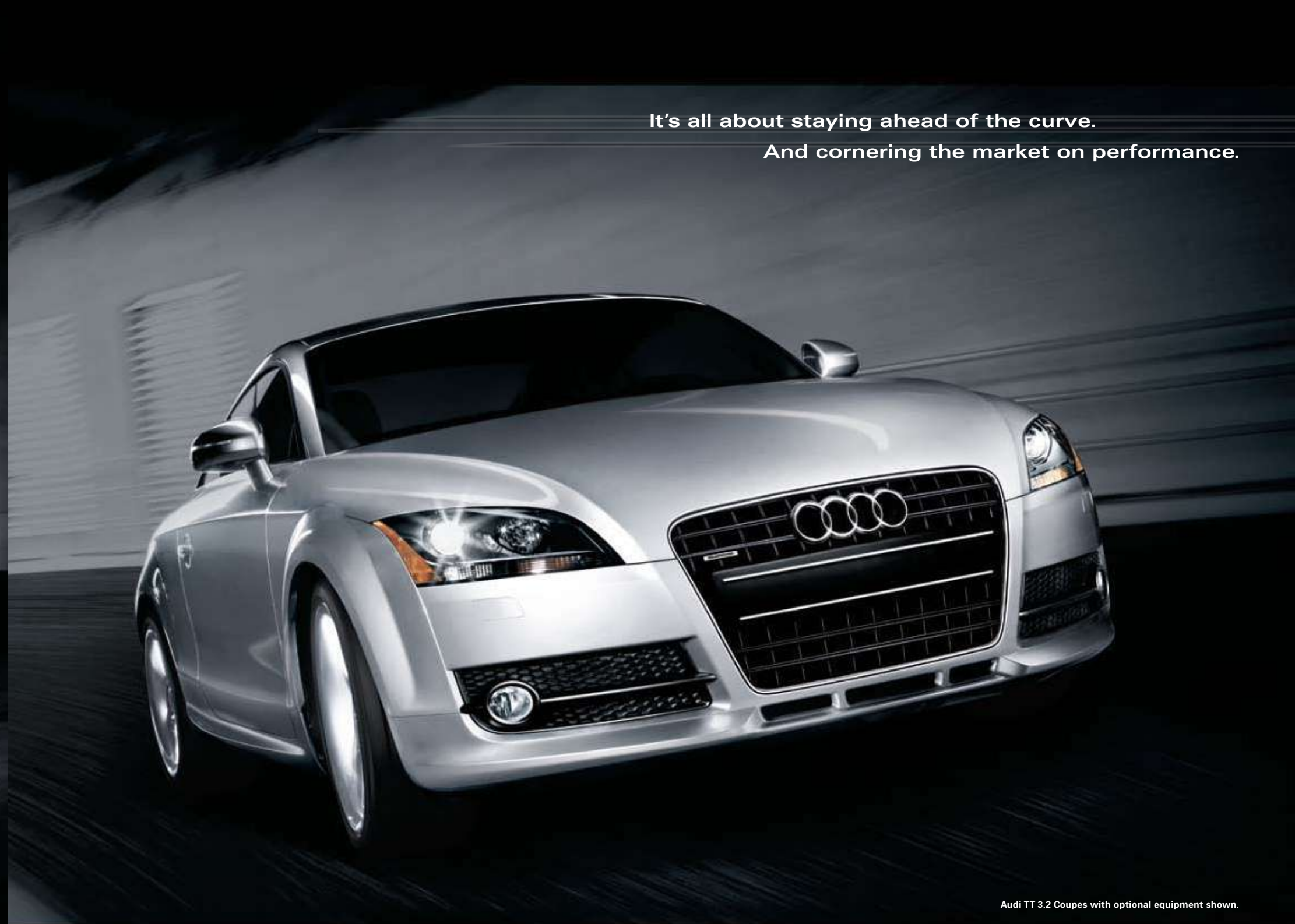

It's all about staying ahead of the curve.
And cornering the market on performance.



Sometimes less is more. Sometimes more is more.
Taking ergonomic excellence to the next level.

A sculptural tour de force.

Absolutely mesmerizing on the road.





Still a beauty. With a bit of the beast. The all-new TT Roadster retains the distinctive lines of its iconic predecessor, but adds powerful, progressive touches. By going with a soft top, we accomplish two goals: A tie to tradition and less weight. Benefits: More power and a lower center of gravity for superior handling.



A compelling case. On so many levels.



A detailed view of the interior of an Audi TT Roadster. The image shows the front passenger seat and the driver's side, including the steering wheel, dashboard, and center console. The seats are upholstered in a rich tan leather with intricate stitching, particularly along the edges and on the seat cushions. The dashboard and door panels are finished in a dark, possibly black, material. The steering wheel is black with the Audi logo in the center. The center console features a gear shifter and handbrake. The overall aesthetic is one of luxury and sportiness.

Purely on aesthetics alone, brilliant.
But wait until you get behind the wheel.

At the heart of every TT, the power to move mountains.

Underneath the sleek aluminum hood of every TT Coupe and Roadster, your choice of eager engines. Engines designed and engineered to deliver power that's both responsive and responsible. Take the turbocharged 2.0 liter variant. With 200 horses at the beck and call of your right foot, abundant power. Now add FSI® Direct Injection: By mixing precise amounts of fuel and air and injecting them directly into each cylinder, we're able to increase power delivery as well as maximize efficiency. With FSI Direct Injection, the 2.0 T achieves a compression ratio of 10.3:1 – a figure once reserved solely for naturally aspirated powerplants. From its award-winning debut at the 2001 24 Hours of Le Mans to now, no technology better illustrates a desire to win in both the short and the long run quite like FSI. Experts once doubted our ability to bring FSI from the track to the street. No more. And no wonder a jury of 56 experts from 26 countries named the 2.0 T International Engine of the Year in its class for 2005 and 2006. Its power delivery is already legendary – 207 lb-ft of torque at just 1800 rpm. Now add the ability to maintain that torque at a constant level all the way to 5000 rpm. No peaks and valleys, a plateau of power.

Coupled with the 2.0 T Coupe's dual-clutch S tronic™ transmission, zero to 60 mph (100 km/h) arrives in a scant 6.1 seconds. Roadster: 6.3. Both markedly faster than their predecessors. Thanks, in good measure, to the rapid and dynamic shifts of the S tronic transmission.

Want even more power? Opt for the powerful 3.2 liter V6. With 250 willing horses and maximum torque delivery of 236 lb-ft between 2500 and 3000 rpm, the 250 hp V6 offers a tantalizing combination of high torque and high revs. Both engines deliver outstanding power-to-weight ratios. In the quattro®-equipped Coupe with S tronic, 0 to 60 mph (100 km/h) in a rapid 5.3 seconds. A combination of style and substance found absolutely nowhere else. By reconfiguring engine mapping, the 3.2 offers instantaneous throttle response with more bite over a wide range of engine speeds. As an added benefit, acoustic engineers have been able to emphasize the intake sounds at all engine speeds as opposed to relying on exhaust notes. It's a tune sure to have you humming. Who needs a radio when you're driving this car?



Top: S tronic manages gear shifts in less than .2 seconds by pre-selecting the next gear. With almost no loss of acceleration.

Bottom: FSI Direct Injection proved a game changer in endurance racing. Not just in the 24 Hours of Le Mans, but in North America's American Le Mans Series (ALMS) as well. The Audi R8: Arguably the world's most successful racecar ever. Thanks to FSI, able to run longer and stronger between pit stops.

**Lightweight ASF: A unique blend of aluminum and steel,
a marriage made in handling heaven.**

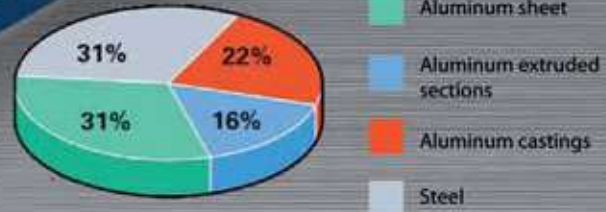
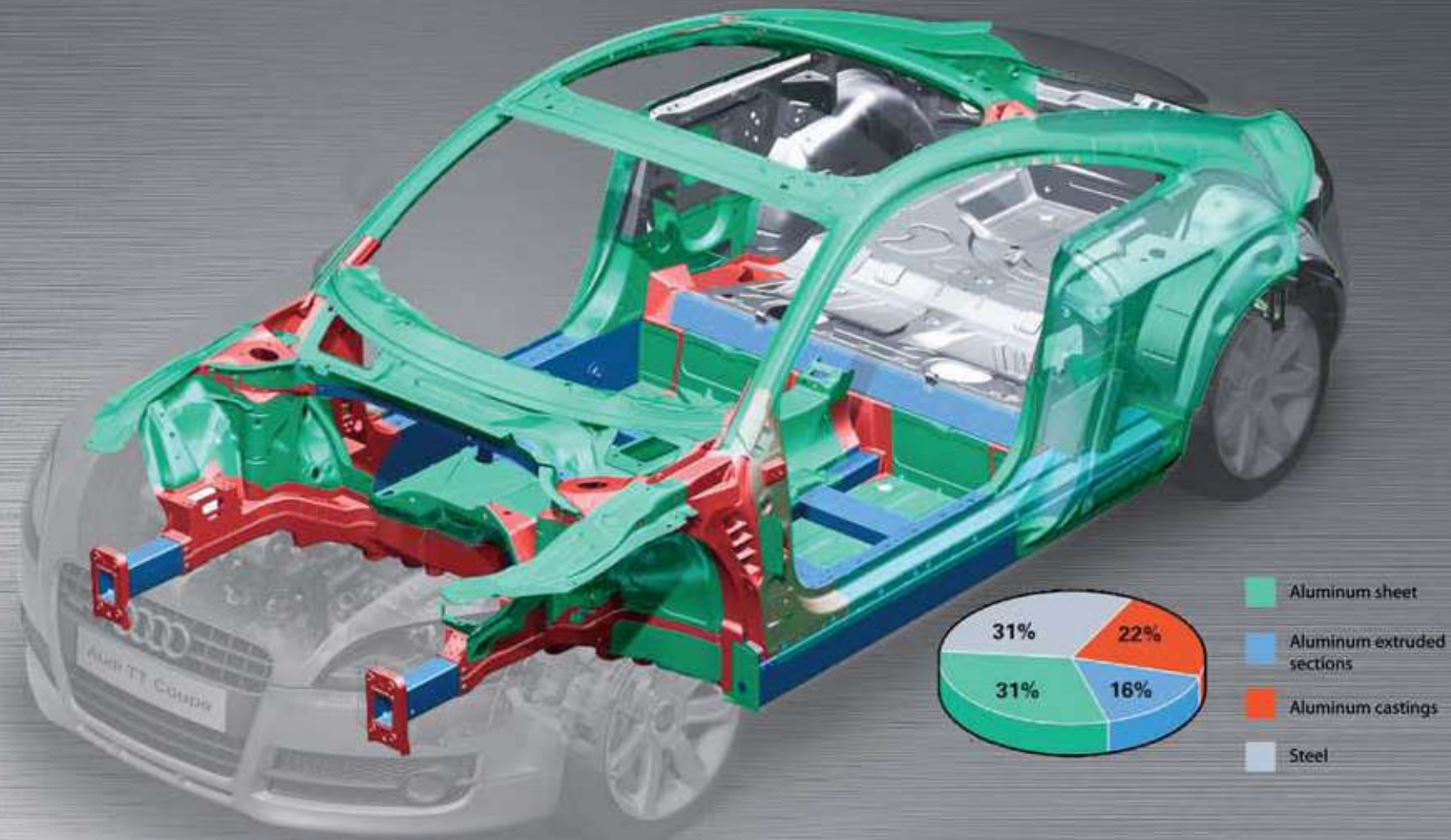

Four wheels can take you only so far. It's what's above those wheels that determines where a sports car lines up on the food chain. And here is where the ASF shines. Whether you opt for quattro all-wheel drive or front-wheel drive, the inherent advantages of blended construction pay dividends. Fuel consumption, handling, safety and more all benefit.

The combination of sheet aluminum, extruded aluminum, aluminum pressure castings and sheet steel all add up to a 21st-century approach to automotive excellence. Our goal is to do more than up the power-to-weight ante; we aim to change the conversation. Nothing less than the proverbial paradigm shift. At Audi, the future is now.

The all-new ASF® in the all-new TT represents a breakthrough – 69% aluminum and 31% steel in the Coupe, 58% aluminum and 42% steel in the Roadster. A unique bodyshell concept tailored to the task at hand. A way to maximize performance, handling and safety like never before, thanks to innovative joining techniques and new alloys. In the Coupe, fully 48% lighter than an equivalent body built of steel. And 45% lighter in the Roadster. But the benefits don't stop there: Outstanding torsional strength. Stability at speed. Exceptional feedback due to the absence of excess vibration. Even the ability to fashion a smooth underbody with no need for an additional undertray. Not to mention improved weight distribution, less fuel consumption, better braking...we could go on and on. And you will. In fact, no carmaker on the planet has more experience with aluminum. Our fascination with the mettle of this extraordinarily versatile metal began in the 1930s with our famed Auto Union racers, intensified in the 1980s when we partnered with Alcoa to create the A8 and continues unabated to this day.

By concentrating aluminum in front with steel in the rear, we're able to achieve benchmarks many thought unattainable. What's more, this blended construction affords freedom to fine-tune both the Coupe and the Roadster individually. For example, the steel bulkhead in the rear serves as an ideal anchor for the new high-strength rollbars in the Roadster. The side sills in both the Roadster and the Coupe have been optimized for maximum efficiency. The A pillar of the Roadster has a high-strength steel tube integrated in its aluminum frame for added strength in the unlikely event of a rollover. In addition to safety and performance benefits, this new ASF affords us tremendous flexibility in dialing in precisely the characteristics we want.

And it's that flexibility that allows us to break new ground in suspensions. In addition to tried-and-true McPherson struts up front mounted to an aluminum subframe, the all-new TT sports a new four-link rear suspension with enhanced damping. Beyond stunning dynamic potential, surprising ride comfort. Thanks, in no small measure, to the character of the ASF. And then in typical Audi fashion, we search for new horizons. Introducing optional Audi magnetic ride. The sports car suspension of the future – today. Continuously adjustable damping not only reduces pitch and roll, it offers surprising comfort. And it all starts by selecting Sport or Standard mode. To find out what altering tiny magnets inside our special shock-absorber fluid does to the brake-dive and pitch-and-roll associated with spirited driving, test-drive the all-new TT with this revolutionary achievement.

The touch of one button changes everything. Whether you opt for Sport or Standard mode, Audi magnetic ride goes to work instantly. Continuously sensing pitch, yaw and speed, it stiffens or softens the ride as if there were a new kind of ESP – extra sensory perception. The new standard. Yet another TT class-exclusive.





Safety first. Safety last. Safety always.

There is no other way.

With advanced technology that grants the all-new TT an ability to go, corner and stop faster than ever before comes a responsibility to provide maximum safety. It goes without saying that your car will feature a vast array of passive systems. From airbags, a highly stable occupant shell, side intrusion protection, tire-pressure monitoring and more, it's all there. But at Audi, our passion remains active safety. After all, an accident avoided is always the preferred scenario.

Both engines will deliver the power you need to overtake slower vehicles. With either quattro or front-wheel drive, enhanced traction on a variety of road surfaces and conditions. The all-new TT also features electro-mechanical Servotronic® steering for sports car moves at speed and ease around town. And then we go a step further: Automatically tapping the brake discs during periods when they're not needed ensures they're completely dry when you do. Thanks to Brake Assist, your TT is able to sense the urgency of the situation and apply additional force if needed.

With a new electronic stabilization program from Bosch® adapted precisely to these cars to Anti-Slip Regulation and more, the TT offers an array of electronic assists. Our goal is to enhance the driving experience and intervene only when absolutely necessary. It's really quite simple: Only those absolutely convinced of their car's safety will truly enjoy the full measure of their performance potential.

From active safety systems to passive ones, we consider every detail. For example, we mount our side airbags in the seats to better account for a range of seating positions. At Audi, safety is everything.

There is an art and a science to joining active and passive safety systems in seamless fashion. The all-new TT exemplifies our devotion to both. From new knee airbags to a magnesium-intensive steering column and gearbox casing, an absolute determination to excel on every level.



Audi TT 3.2 Coupés with optional equipment shown.

Whether S stands for Sport, Sophistication
or oh-so Sexy is entirely up to you.



Introducing the 2008 TT S line package. In Germany, where performance cars are a national obsession, readers of *AutoBild* voted the new TT the most beautiful car in the world. The 2008 TT S line package confirms their opinion. And then some. Our customization and performance subsidiary, quattro GmbH, has gone into overdrive to work its magic on these cars. Special touches abound: Black stitching on its well-bolstered Fine Nappa leather seats. As well as a distinctive grille, front diffuser and more. The result? A TT that fits you to a T.

From commemorative badging on the black Fine Nappa leather sports seats and sporty front and rear bumpers, there are obvious signs that your TT is an S line. The TT S line package sports special 19-inch, seven-arm cast alloy wheels and an all-around feel of a finely crafted sports car.

New for 2008: European delivery. Your first drive in a TT S line package will be memorable no matter where you start. But never as special as a drive that begins in Bavaria. After a tour of our factory in Ingolstadt and a visit to the Museum Mobile, the Autobahn awaits. And after your trip to Europe, we'll have your new Audi shipped to your local dealer.* Wunderbar.

*Available to U.S. customers only.

From left:

You'll find the S line badge both on the exterior and the interior. As well as on the flat-bottom Sport steering wheel with special S line stitching.

The way to roll: 19-inch, seven-arm cast alloy wheels with eye-catching double-spoke design.

The unique steering wheel is covered in leather that is hand-stitched with contrasting threads.

We invite you to drive a car that's
as full of life as you are.



From left to right:
Textile floor mats with TT logo
19-inch, five-arm aluminum wheel
Rubber floor mats
Splash guards

When you shop for Audi Accessories, you can rest assured that every item matches your lofty expectations of Audi. Exquisite form. Extreme function. Unadulterated style. Real substance. In other words, if it's not up to our standards, you won't find our name on it.

Adding substance to your style. Whether it's form or function or a bit of both that you're after, we encourage you to make your TT yours. And yours alone. From wheels to roof racks to mats and more, possibilities are expanding every day. In fact, we advise you to bookmark audiusa.com or audicanada.ca and check out the Audi Accessories for yourself. It's constantly updated and there are frequently special offers to consider.

In fact, the Web is the place to go to find out all the latest news on Audi. Whether it's new models or news from the world of motorsports, we've got you covered.



Model Configurations

TT Coupe

- ▶ 2.0 T FSI® 200 hp / FWD / 6-speed S tronic™
- ▶ 3.2 V6 250 hp / quattro® AWD / 6-speed manual
- ▶ 3.2 V6 250 hp / quattro AWD / 6-speed S tronic

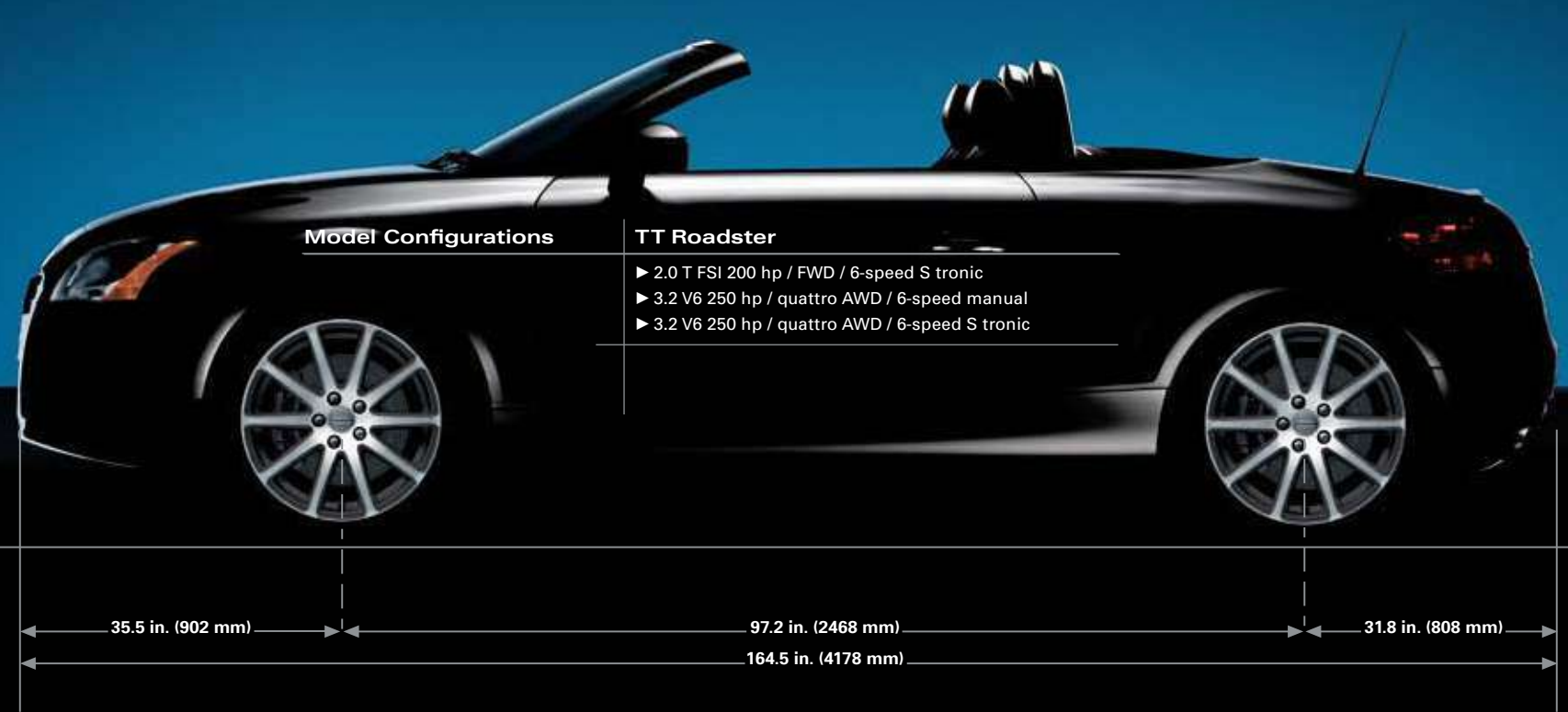

Model Configurations

TT Roadster

- ▶ 2.0 T FSI 200 hp / FWD / 6-speed S tronic
- ▶ 3.2 V6 250 hp / quattro AWD / 6-speed manual
- ▶ 3.2 V6 250 hp / quattro AWD / 6-speed S tronic

Dig a little deeper. Both the TT Coupe and TT Roadster are longer and wider than their predecessors. And yet both are stronger and more rigid as well. We urge you to study the facts and figures herein to see for yourself that the promise of these sports cars is unlimited. In the following pages you'll begin to understand the depth of options and possibilities available to TT drivers. We encourage you to configure one to your precise specifications. The Web and your dealer will also be able to help. There is, however, no substitute for a vigorous test-drive.

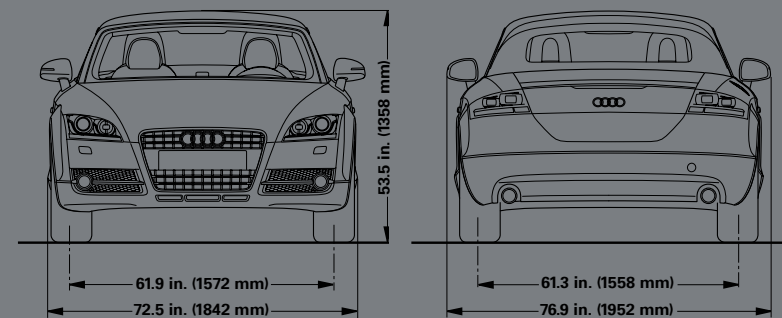
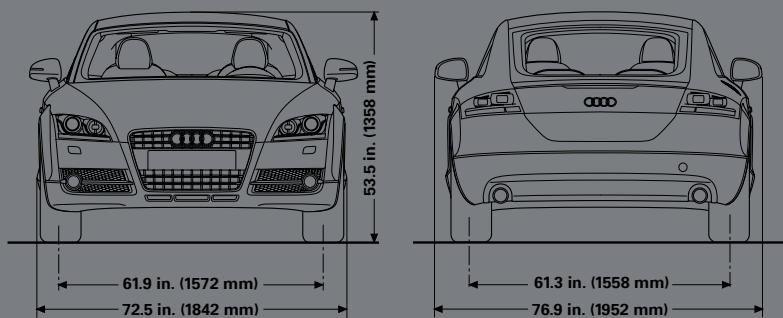

TT Coupe / TT Roadster Power and Performance

ENGINES

- ▶ 2.0 liter turbocharged in-line 4-cylinder with FSI Direct Injection, 4 valves per cylinder
- ▶ Displacement: 2.0 liters (1984 cc) ▶ Bore: 3.25 in. (82.5 mm) ▶ Stroke: 3.65 in. (92.8 mm)
- ▶ Compression ratio: 10.3:1 ▶ Horsepower: 200 hp @ 5100-6000 rpm ▶ Torque: 207 lb-ft @1800-5000 rpm
- ▶ 3.2 liter 15-degree V6 with 4 valves per cylinder
- ▶ Displacement: 3.2 liters (3189 cc) ▶ Bore: 3.31 in. (84.0 mm) ▶ Stroke: 3.78 in. (95.9 mm)
- ▶ Compression ratio: 11.3:1 ▶ Horsepower: 250 hp @ 6300 rpm ▶ Torque: 236 lb-ft @ 2500-3000 rpm

PERFORMANCE

- ▶ **2.0 T**
- ▶ 0-60 mph (0-100 km/h) in seconds: Coupe: 6.1; Roadster: 6.3 ▶ Top track speed¹: 130 mph (209 km/h)
- ▶ Total fuel consumption: Coupe: 26 mpg; Roadster: 25 mpg
- ▶ **3.2**
- ▶ 0-60 mph (0-100 km/h) in seconds: Coupe / S tronic: 5.3; Coupe / manual: 5.5; Roadster / S tronic: 5.6; Roadster / manual: 5.8 ▶ Top track speed¹: 130 mph (209 km/h) ▶ Total fuel consumption: Coupe S tronic: 20 mpg; Coupe manual: 19 mpg; Roadster S tronic: 20 mpg; Roadster manual: 19 mpg

¹Maximum speed electronically limited to 130 mph in the U.S. (209 km/h in Canada)
²Not available at time of printing. See your local Audi dealer for details.

Audi TT Specifications

Standard Equipment TT 2.0 T Coupe and Roadster

Engine / Transmission / Suspension / Body

- ▶ ASF® lightweight construction mixed of aluminum and steel
- ▶ McPherson front suspension with aluminum subframe
- ▶ Four-link rear suspension with enhanced damping system
- ▶ Servotronic® electromechanical steering with speed-dependent power assistance
- ▶ Dual-circuit brake system
- ▶ Electronic Stabilization Program (ESP®)
- ▶ Anti-lock Brake System (ABS)
- ▶ Anti-slip regulation (ASR)

Exterior

- ▶ Single frame grille in titanium gray
- ▶ Automatic rear spoiler, includes manual operation feature
- ▶ Two-way ellipsoidal halogen projector headlamps
- ▶ Fog lights in the front
- ▶ TT badge on fuel filler door and trunk
- ▶ Aluminum fuel filler door and door sills
- ▶ Automatic adjustable and heated side mirrors
- ▶ Heated windshield washer nozzles
- ▶ LED indicator lights integrated in side mirrors
- ▶ LED third brake light
- ▶ Dual chrome-tipped exhaust pipes, positioned left
- ▶ Manually retractable soft top; self-storing (Roadster only)
- ▶ Glass-heated rear window

Interior

- ▶ Sport seats with leather/Alcantara® surfaces, manually adjustable
- ▶ Three-spoke flat-bottom leather-wrapped Sport steering wheel
- ▶ Driver-oriented cockpit
- ▶ Brushed aluminum trim
- ▶ Aluminum-optic applications
- ▶ Illuminated glove box, rear cargo area and vanity mirrors in sunvisors
- ▶ Automatic air conditioning, one-zone
- ▶ Center console with two cup holders and storage area
- ▶ Four hooks and removable cover in trunk
- ▶ Manually adjustable tilt-and-telescopic steering column
- ▶ Electric rear window defogger with automatic, timed shut-off feature
- ▶ Radio frequency remote locking system with selective unlock, remote decklid/trunk opening, panic function, interior lights and alarm system activation – control integrated into folding ignition key
- ▶ Power windows with power retention, “one-touch up,” “one-touch down” and pinch protection for all windows
- ▶ Seating capacity – Coupe: 2+2; Roadster: 2
- ▶ 50/50 split-folding rear seat (Coupe only)
- ▶ Automatic retractable wind deflector (Roadster only)
- ▶ Heated seats (Canada only)

Electronics

- ▶ Driver information system with onboard computer
- ▶ Backlit instrument cluster with automatic brightness control
- ▶ Electronic cruise control with coast, resume and acceleration features
- ▶ Audi Concert AM/FM stereo with in-dash CD player including MP3 capability
- ▶ Satellite radio preparation¹
- ▶ Six CD-changer preparation
- ▶ Nine-speaker, 140-watt sound system
- ▶ Tire-pressure monitoring system

Safety / Security

- ▶ Full-size dual threshold airbags for driver and front passenger²
- ▶ Driver and front-passenger seat-mounted chest side airbags²
- ▶ Driver and front-passenger knee airbags²
- ▶ Rigid body shell with special energy-absorbing zones
- ▶ Side intrusion protection
- ▶ Anti-theft vehicle alarm system
- ▶ Tool kit
- ▶ Seat belts, three-point inertia-reel, for all occupants, with belt tensioners and force limiters at the front
- ▶ Lower Anchors and Tethers for Children (LATCH) in rear (Coupe only)
- ▶ Audi backguard system
- ▶ Power central locking system with safety unlock feature if airbag deploys
- ▶ Reflectors in all doors
- ▶ Valet key

TT 2.0 T Premium package (Includes TT 2.0 T standard equipment)

- ▶ Multi-function three-spoke flat-bottom leather-wrapped Sport steering wheel (includes paddle shifters on S tronic models)
- ▶ HomeLink® remote transmitter
- ▶ Heated front seats
- ▶ 10-way power driver and front passenger seats including 4-way power lumbar adjustment
- ▶ Auto-dimming interior mirror with compass, rain and light sensor and “coming home/leaving home” function
- ▶ Audi Symphony AM/FM stereo with in-dash 6-disc CD changer including MP3 capability
- ▶ Fully automatic retractable soft top (Roadster only)

TT 3.2 (Includes TT 2.0 T Premium package equipment)

- ▶ Single frame grille in high-gloss black
- ▶ Dual chrome-tipped exhaust pipes split right/left
- ▶ Lights styling package
- ▶ Bi-xenon headlight washer (Canada only)
- ▶ Bi-xenon adaptive headlights with daytime running lights
- ▶ Metallic or pearl effect exterior paint

¹Satellite radio currently only available in continental U.S. See your Audi dealer for details. ²Airbags are supplemental restraints only and will not deploy under all accident circumstances. Always use safety belts and seat children only in the rear, using restraint systems appropriate for their size and age (Coupe). When small children must ride in the passenger seat, move it fully rearward. Follow instructions and read all warnings in the owner’s manual (Roadster).

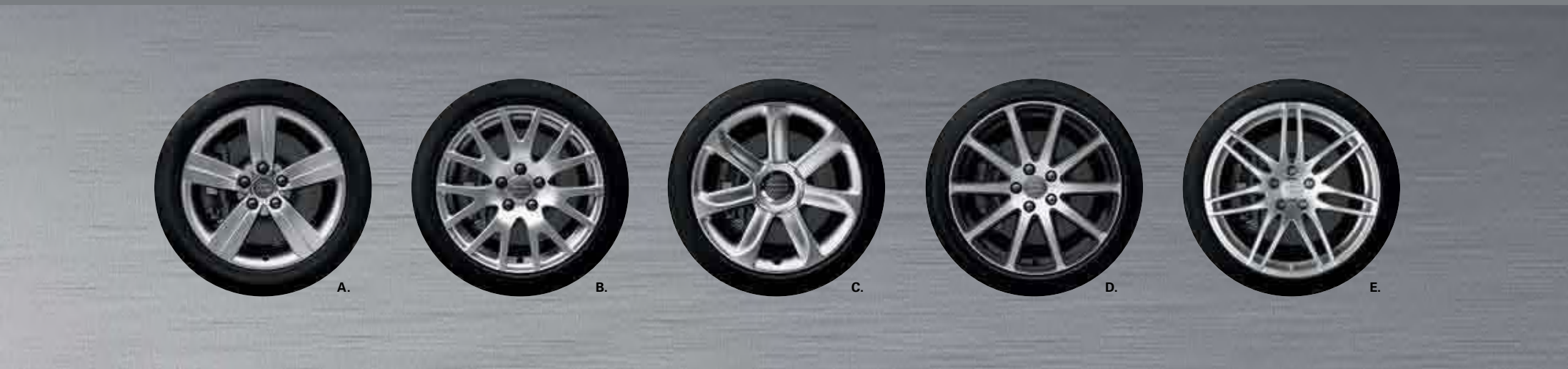

Wheels

2.0 T	2.0 T Premium package	3.2	Wheels
S	S	n/a	(A) 17-inch 5-arm cast alloy wheels with 225/50 high-performance* or all-season Self-Supporting run-flat (SST) tires**
n/a	n/a	S	(B) 17-inch 7 Y-spoke cast alloy wheels with 245/45 high-performance* or all-season Self-Supporting run-flat (SST) tires**
n/a	O	O	(C) 18-inch 7-arm cast alloy wheels with 245/40 high-performance* or all-season Self-Supporting run-flat (SST) tires**
n/a	n/a	O	(D) 18-inch 10-spoke bi-color cast alloy wheels with 245/40 high-performance* or all-season Self-Supporting run-flat (SST) tires**
n/a	O	O	(E) 19-inch 7-arm double-spoke cast alloy wheels with 255/35 high-performance tires* (included in S line package)

S = standard O = optional n/a = not applicable

*Performance tires are designed for optimum performance and handling in warm climates. They are not suitable for cold, snowy or icy weather conditions. If you drive under those circumstances, you should equip your vehicle with all-season or winter tires, which offer better traction under those conditions. We suggest you use the recommended winter or all-season tires specified for your car or its equivalent. These high-performance tires also have a lower aspect ratio that aids performance and handling; however, in order to avoid tire, rim or vehicle damage, it is important that the inflation pressure is regularly checked and maintained at recommended levels. Serious wheel and tire damage may occur if the vehicle is operated on rough or damaged road surfaces or upon encountering road debris or obstacles. Please also remember in making your selection that, while these tires deliver responsive handling, they may ride less comfortably and make more noise than other choices. Finally, these tires may wear more quickly than other choices. For more information on all of these topics, please consult the owner’s manual, your local dealer or call 1-800-FOR-AUDI. **New for 2008 TT Coupe and TT Roadster: The option of Self-Supporting (SST), or run-flat, tires. Available in all sizes except S line wheel (E). In the event of tire damage with a resultant loss of pressure, it is possible to continue driving a distance of at least 30 miles (48 kilometers) at a maximum speed of 50 mph (80 km/h). All tires are coupled to a tire-pressure monitoring system which warns the driver if the tire pressure drops below a minimum preset value.

Audi TT Specifications

TT 2.0 T	TT 2.0 T Premium package	TT 3.2	Option Packages
n/a	O	O	Audio package
n/a	O	O	Enhanced Interior package
n/a	O	O	Audi Exclusive Line (Requires Enhanced Interior package)
n/a	O	O	S line Sport package
Individual Options			
O	S	S	Heated front seats (Standard in Canada)
O	n/a	n/a	SIRIUS® Satellite Radio (U.S. only)
O	S	S	Fully automatic retractable soft top (Roadster only)
O	O	O	All-season Self-Supporting run-flat (SST) tires*
O	O	O	Metallic or pearl effect exterior paint (Standard on 3.2 models in Canada)
n/a	O	O	Bi-xenon adaptive headlights with daytime running lights (Standard on 3.2 models in Canada)
n/a	O	O	iPod® interface
n/a	O	O	Audi Navigation plus, includes 6-disc CD changer or iPod interface**
n/a	O	O	Phone preparation with Bluetooth® interface (Optional on all models in Canada)
n/a	O	O	Audi magnetic ride suspension
n/a	O	O	Audi parking system
n/a	O	O	Baseball-optic leather seats (Roadster only; requires Enhanced Interior package)
n/a	O	O	18-inch 7-arm alloy wheels with 245/40 high-performance tires¹
n/a	n/a	O	18-inch 10-spoke bi-color cast alloy wheels with 245/40 high-performance tires¹

S = standard O = optional n/a = not applicable

Audio package

- ▶ Bose® premium 12-speaker, 255-watt sound system with AudioPilot® noise-compensation feature
- ▶ SIRIUS Satellite Radio

Enhanced Interior package

- ▶ Fine Nappa leather seat upholstery
- ▶ Leather-covered select interior components (e.g., center console and door inserts)
- ▶ Storage package (e.g., folding compartments under front seats)
- ▶ Seat release (Roadster only)
- ▶ Load-through facility (Roadster only)
- ▶ Two storage compartments in rear panel (Roadster only)

Audi Exclusive Line (Requires Enhanced Interior package)

- ▶ Black Fine Nappa leather seats with a selection of insert colors
- ▶ Insert color options: Crimson Red, Saddle Brown, Signal Orange and Silver
- ▶ Black leather covered select interior components (e.g., center console and door inserts)
- ▶ Color-keyed stitching on select interior components
- ▶ Door sill trims with Audi Exclusive emblem (Coupe only)
- ▶ Color-keyed leather door inserts in front, black in rear
- ▶ Black headliner and carpet
- ▶ Floor mats with black piping and color-keyed stitching

S line Sport package

- ▶ 19-inch 7 double-spoke cast alloy wheels with 255/35 high-performance tires¹ and tire mobility system
- ▶ S line grille, bumpers and gray front diffuser
- ▶ S line door sills
- ▶ S line badges
- ▶ Headlight washer nozzles
- ▶ Black leather / Fine Nappa Leather seats with black stitching and embossed S line logo
- ▶ Black leather-covered interior components
- ▶ Black stitching on leather covered interior components
- ▶ Leather-wrapped 3-spoke multi-function steering wheel (includes paddle shifters on S tronic models)
- ▶ Short-throw manual gear shift (3.2 models only)

*In the event of tire damage with a resultant loss of pressure, it is possible to continue driving a distance of at least 30 miles (48 kilometers) at a maximum speed of 50 mph (80 km/h). All tires are coupled to a tire-pressure monitoring system which warns the driver if the tire pressure drops below a minimum preset value. **The Audi Navigation System depends upon signals from the worldwide Global Positioning Satellite network. The vehicle's electrical system, and existing wireless and satellite technologies, must be available and operating properly for the system to function. The system is designed to provide you with suggested routes in locating addresses, destinations and other points of interest. Changes in street names, construction zones, traffic flow, points of interest or other road system changes are beyond the control of Audi of America, Inc. or Audi Canada. Complete, detailed mapping of lanes, roads, streets, toll roads, highways, etc., is not possible, therefore you may encounter discrepancies between the mapping and your actual location. Please rely on your individual judgment in determining whether or not to follow a suggested Audi Navigation System route. Periodically the mapping is updated and a new DVD will be required in order to maintain the latest navigation information available to us. These will be available for purchase from time to time at additional cost. Consult your dealer or call 1-800-FOR-AUDI for details. †Performance tires are designed for optimum performance and handling in warm climates. They are not suitable for cold, snowy or icy weather conditions. If you drive under those circumstances, you should equip your vehicle with all-season or winter tires, which offer better traction under those conditions. We suggest you use the recommended winter or all-season tires specified for your car or its equivalent. These high-performance tires also have a lower aspect ratio that aids performance and handling; however, in order to avoid tire, rim or vehicle damage, it is important that the inflation pressure is regularly checked and maintained at recommended levels. Serious wheel and tire damage may occur if the vehicle is operated on rough or damaged road surfaces or upon encountering road debris or obstacles. Please also remember in making your selection that, while these tires deliver responsive handling, they may ride less comfortably and make more noise than other choices. Finally, these tires may wear more quickly than other choices. For more information on these topics, please consult the owner's manual, your local dealer or call 1-800-FOR-AUDI.



A.



B.



C.



D.



E.

(A) Vivid screen of Audi Navigation plus with intuitive MMI® logic.

(B) Button on the far left activates the Standard or Sport mode of the versatile new Audi magnetic ride system.

(C) New 18-inch 7-arm cast alloy wheel is available on the 2.0 T with Premium package and the 3.2 models.

(D) Heated front seats. Standard on 2.0 T with Premium package and 3.2 models. (Standard in Canada)

(E) Iconic baseball-optic leather seats are available on the 2.0 T Roadster with Premium package and the 3.2 Roadster.

Color Choices

Exterior Colors	Leather/Alcantara Seating	Fine Nappa Leather Seating (Enhanced Interior Package) [†]
Ibis White	Black, Limestone Gray,	Black, Limestone Gray, Luxor Beige, Magma Red, Madras Brown, Black (S line)
Brilliant Red	Black, Limestone Gray,	Black, Limestone Gray, Luxor Beige, Black (S line)
Brilliant Black	Black, Limestone Gray,	Black, Limestone Gray, Luxor Beige, Magma Red, Madras Brown, Black (S line)
Light Silver metallic	Black, Limestone Gray,	Black, Limestone Gray, Magma Red, Madras Brown, Black (S line)
Sahara Silver metallic	Black, Limestone Gray,	Black, Limestone Gray, Magma Red, Madras Brown, Black (S line)
Ocean Blue pearl effect	Black, Limestone Gray,	Black, Limestone Gray, Luxor Beige, Madras Brown, Black (S line)

Seating	Trim	Dashboard	Carpet	Headliner (Coupe)	Soft Top (Roadster)
Black	Brushed Aluminum	Black	Black	Black	Black
Limestone Gray	Brushed Aluminum	Black	Limestone Gray	Limestone Gray	Black
Luxor Beige	Brushed Aluminum	Black	Luxor Beige	Luxor Beige	Black
Magma Red*	Brushed Aluminum	Black	Black	Black	–
Madras Brown Baseball-optic leather**	Brushed Aluminum	Black	Black	–	Black
Black with Black stitching ^{††}	Brushed Aluminum	Black	Black	Black	Black

[†]Available with Premium package only.

^{*}Available on TT Coupe models only.

^{††}Available with S line package only.

^{**}Available on TT Roadster models only.

Audi Exclusive Package

Seating	Trim	Dashboard	Carpet	Headliner (Coupe)	Soft Top (Roadster)
Crimson Red	Brushed Aluminum	Black	Black	Black	Black
Saddle Brown	Brushed Aluminum	Black	Black	Black	Black
Signal Orange	Brushed Aluminum	Black	Black	Black	Black
Silver	Brushed Aluminum	Black	Black	Black	Black

Interior Seating/Trim



Exterior Colors

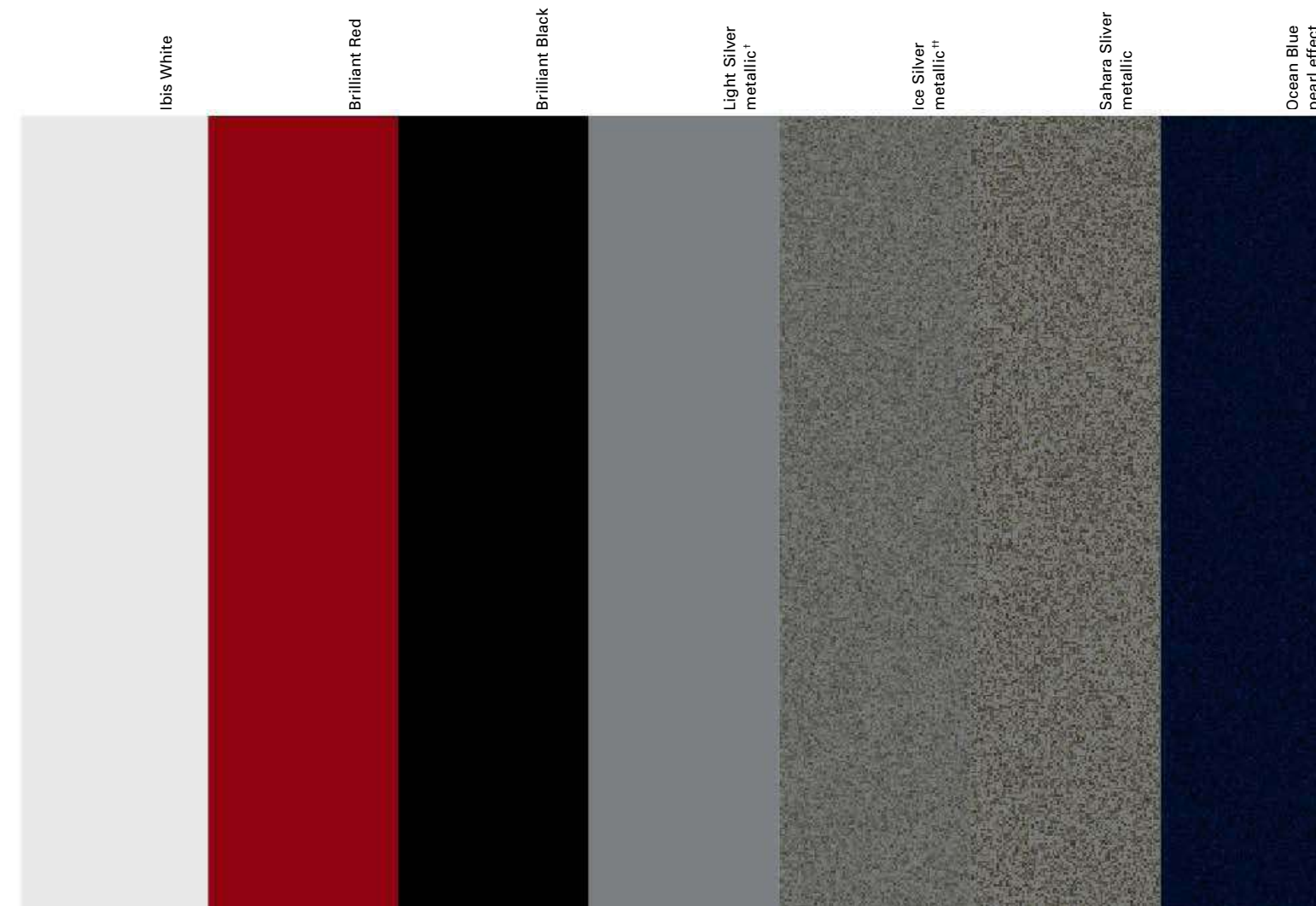

Audi Exclusive Line



^{*}Available on TT Coupe models only.
^{**}Available on TT Roadster models only at additional cost.
[†]Available until May 2007.
^{††}Available after May 2007.