

1964



CHEVROLET
TRUCK
ENGINEERING
FEATURES





ENGINEERING PRODUCT INFORMATION DEPARTMENT

SEPTEMBER, 1963

19664

CHEVROLET
TRUCK
ENGINEERING
FEATURES

FOREWORD

The 1964 program furthers Chevrolet's continuing pattern of dynamic truck engineering progress. Nine new models, extensive body and chassis refinements, and a host of power train improvements promote the qualities of durability, dependability, driver convenience, and line-up versatility. Styling changes complement the engineering development program with a fresh, new appearance. New features are detailed in the following pages.

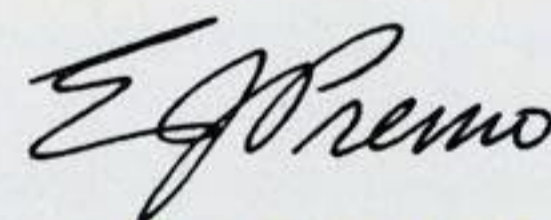

CHIEF ENGINEER

CONTENTS

THE 1964 CHEVROLET TRUCK . . .	5
MODEL LINE-UP	9
EXTERIOR STYLING	17
INTERIOR STYLING	26
BODY	37
POWER TRAIN	57
CHASSIS	67
THE EL CAMINO	75
INTERIM 1963 CHANGES	90
APPENDIX	99
INDEX	106

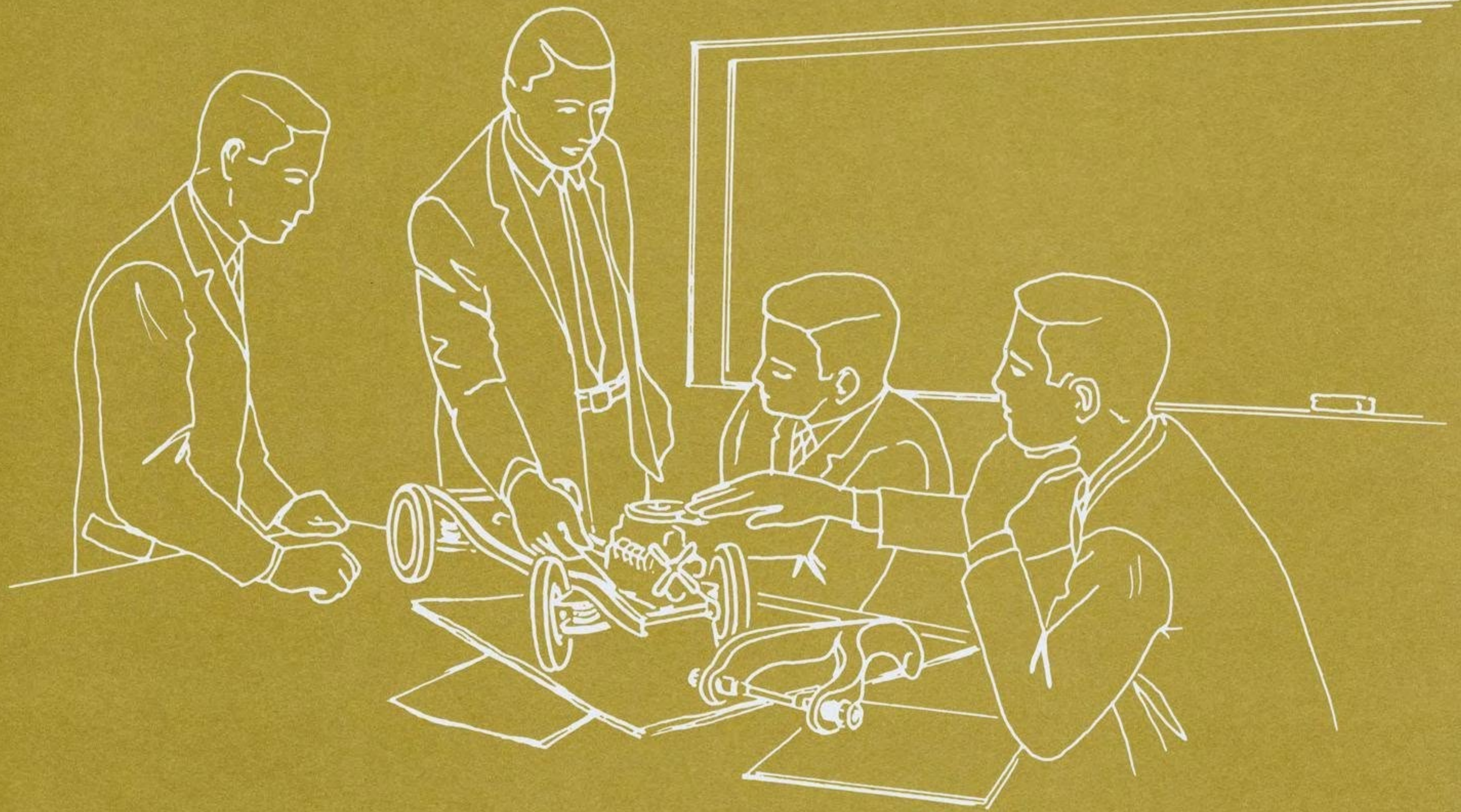

THE 1964 CHEVROLET TRUCK

The truck program for 1964 basically continues the existing proven design, but incorporates numerous evolutionary changes to further extend the product durability, utility, and vocational diversification.

Numerically, the line-up is expanded by nine new models to 193 on 21 wheelbases. Additions include two new sedan pickup vehicles, labelled the ElCamino and Custom ElCamino. Differences between the two consist only of exterior and interior trim and each is available in 6 or 8-cylinder engine versions. Styling, body structure, and chassis design are basically that of the 1964 Chevelle passenger car. Also added are three new LCF diesel tandems. These are identical in cab configuration to the carryover Series E80 models and powered by a 6V-53 Detroit Diesel engine, but equipped with two Eaton single-speed axles, coupled with a Hendrickson suspension for a rear suspension rating of 30,000 pounds.

The other four new models include forward control vans, two each in the P20 and P30 Series. These are also available in optional heights and lengths. Thus, coupled with added sizes to existing Step-Van models, there exists for 1964 a total of 21 van body variations.

Extensive styling and body changes provide the conventional line with a fresh, new appearance. The major item of change is the revised side door opening configuration. The hinge pillar dog-leg has been eliminated and with it the wrap-around windshield. This revision not only facilitates entry and exit, but also results in increased cab torsional strength and an appearance along contemporary styling lines. Other highlights include new grilles, hub caps, and series designation plates. On the interior, the entire instrument panel, cluster, door inner panels, and seat trims are completely restyled.

Other cab structural features for 1964 include improved front door locks; improved interior ventilation; more durable inside fuel tank mounting; improved windshield retention; more durable seat cushion construction; lower transmission tunnel for Series C10, 20 models; improved front body mounts for Series CK10 models, except panels and suburbans; and new cab sound deadening

and insulation materials for both standard and custom models.

The field-tested and proven chassis design of the previous year is continued for 1964, but with many important improvements. Light-duty models are equipped with self-adjusting brakes and incorporate suspension and steering component changes necessary to provide a 6000-mile lubrication interval. Series P20 and P30 models incorporate improved rear shock absorbers, and a new front suspension stabilizer bar option is provided for C10, 20, and 30 models. Duo-servo type brakes replace the non-servo on the front axles of all 4-wheel drive vehicles.

In the medium and heavy-duty category, the changes include the availability of a new 23,000-pound capacity rear axle with new Stopmaster, wedge-type air brakes. Rubber insulated front spring rear hangers on Series 50 and 60 models increase cam durability and improve front end ride qualities. Other improvements include larger diameter steering tie-rod tubes for all medium and heavy-duty models; improved air brake assembly camshaft and chamber sealing; improved parking brake for the New Process 5-speed transmission; larger base tires for M80 models; and extended applicability of heavy-duty wiring to the medium-duty category.

Power train availability remains basically unchanged for 1964. However, significant improvements to existing components further promote performance, durability, and serviceability. A new stainless steel exhaust manifold heat valve is included in the 153, 230, and 292 cubic inch displacement engines. Use of this high heat and corrosion resistant material minimizes the possibility of a sticking valve and resultant problems of carburetor icing or vapor lock and improper fuel vaporization.

The 230, 283, and 292 cubic inch engines also feature a disposable oil-wetted paper element air cleaner element to replace the polyurethane unit. The larger dirt capacity of the new unit makes it particularly effective under adverse operating conditions.

The 292 cubic inch engine boasts a power increase of 5 horsepower to 170 gross with a redesigned camshaft. The substantially higher valve lift improves the engine volumetric efficiency with resultant increases in power. Also, changed ramp and lobe

contours improve camshaft durability despite the higher lift.

The 327 cubic inch engine incorporates an improved water-pump by-pass system to assure an effectively gradual engine warm-up and minimize the possibility of hot-spot formation. The 348, 409, and 4-53, and 6V-53 engines are unchanged for 1964. Optional availability of the 348 cubic inch 2-barrel carburetor version, however, is extended to include all Series 60 models.

Transmissions for 1964 include numerous design refinements, as well as extended availability. The Chevrolet 3-speed and

Powerglide promise improved bushing durability through a new 2-piece propeller shaft. Availability of both the standard and close-ratio Spicer 5-speed units is enlarged to include Series 60 models, wherein only the Clark was previously available.

Refinements to the TV valve of the Powermatic units reduces sensitivity to adjustment and thereby improves performance characteristics.

In the area of rear axles, ratio changes and component refinements improve vehicle performance and contribute to an increase in overall durability. Revisions include new differential side

PROGRAM HIGHLIGHTS

193 MODELS, 21 WHEELBASES

TWO NEW EL CAMINO PICKUPS

THREE NEW LCF DIESEL TANDEMS

FOUR NEW STEP-VANS

NEW RADIATOR GRILLES, HUB CAPS

NEW SERIES PLATES

NEW EXTERIOR COLORS

NEW SEAT TRIMS

NEW INSTRUMENT PANEL, DOOR STYLING

NEW CORVAIR 95 WHEEL TRIM DISK

NEW CUSTOM CAB TRIM PLATE

REVISED CAB DOOR OPENING

IMPROVED BODY INSULATION

IMPROVED FRONT BODY MOUNTS - CK10

NEW CORVAIR 95 AIR INLET SHUT-OFF

NEW CORVAIR 95 UNDERBODY SHIELDING

NEW HEATERS AND DEFROSTERS

NEW AIR CONDITIONING PACKAGE

NEW FOAM SEAT CUSHION

IMPROVED BODY VENTILATION

NEW DOOR LOCKS

NEW CORVAIR 95 ENGINE ACCESS DOOR

IMPROVED WINDSHIELD RETENTION

NEW INSIDE FUEL TANK MOUNTING

LOWER TRANSMISSION TUNNEL - C10, 20

NEW REAR STEP-BUMPER - PICKUPS

gears and stronger brake flange plate attachment on Series 10 rear axles. A new front pinion bearing is incorporated in Series 20, 30, and 50 units. Synthetic rubber replaces leather as the pinion oil seal material in 15,000 and 17,000 pound units. Also, tandem rear axle availability is increased with a higher capacity option. Two heavy-duty Eaton axles, in combination with the RT320 Hendrickson suspension provide a 34,000-pound bogie option for MW80 models.

The most significant change in the Corvair 95 Series is the increase in engine power. The 145 cubic inch displacement unit

is replaced by a 164 cubic inch unit. The displacement increase is achieved by an increase in the piston stroke from 2.60 to 2.94 inches. As a result, power is increased from 80 to 95 gross horsepower. Furthermore, an optional high-performance, 110 horsepower engine also is available for the 1964 Corvair 95's.

Other improvements to these engines include an alloy steel crankshaft, premium aluminum bearings, silichrome inlet valves, increased connecting rod sections, and redesigned pistons. Die-cast magnesium replaces fabricated steel as the engine cooling blower material for longer belt and bearing life.

PROGRAM HIGHLIGHTS

TUBE-AND-CENTER RADIATORS – ALL
SERIES 50, 60

IMPROVED EXHAUST SYSTEMS

NEW EXHAUST MANIFOLD HEAT VALVE –
153, 230, 292 ENGINES

NEW OPTIONAL FUEL FILTER – 230, 283,
292 ENGINES

NEW AIR CLEANERS – 230, 283, 292
ENGINES

HIGHER LIFT CAMSHAFT – 283, 292
ENGINES

IMPROVED WATER PUMP BY-PASS –
327, 348 ENGINES

NEW 164 CU.IN. DISPLACEMENT ENGINE –
CORVAIR 95 LINE

IMPROVED 3-SPEED AND 4-SPEED
TRANSMISSIONS

EXPANDED 5-SPEED TRANSMISSION
LINE-UP – SERIES 60

NEW 23,000 POUND REAR AXLES –
CELTU80

NEW AIR-TORSION SPRING SHIFT –
23,000 POUND 2-SPEED AXLE

NEW TANDEM AXLES – MW80

NEW SELF-ADJUSTING BRAKES –
CKP10, 20

NEW HEAVY-DUTY BRAKES – SERIES 80
WITH 23,000 POUND AXLE

6000-MILE LUBRICATION INTERVALS –
CP10, C20-30

NEW FRONT SPRING REAR HANGER –
CDLMS50-60

NEW WIRING HARNESS INSULATION –
SERIES 50, 60

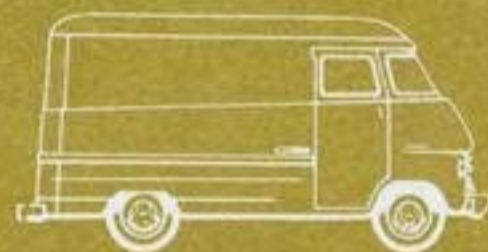
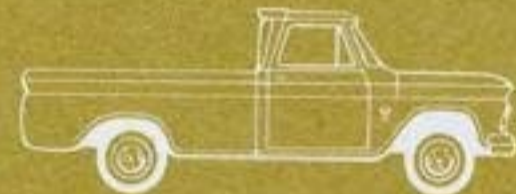
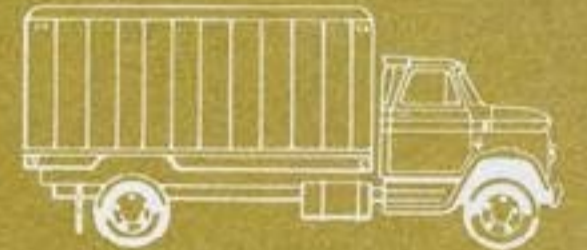
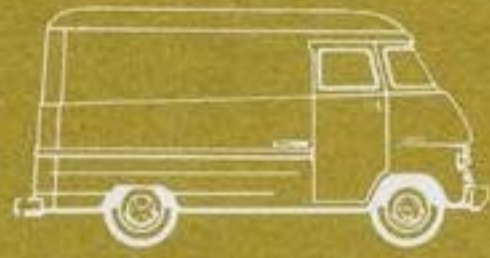

◆ TWO NEW EL CAMINO SEDAN PICKUPS

◆ THREE NEW LCF DIESEL TANDEMS

◆ FOUR NEW FORWARD CONTROL VANS

◆ 193 MODELS, 21 WHEELBASES

model line-up

MODEL LINE-UP

Highlighting the 1964 truck program is an expanded model line-up featuring nine new models. Total model count rises to 193 from 184, while wheelbase count rises to 21 from 19. New model additions are comprised of two sedan pickups, three Low Cab Forward diesel tandems, and four forward control vans.

The new sedan pickups have a wheelbase of 115 inches and a Gross Vehicle Weight rating of 4300 pounds. Two basic models are offered -- the El Camino, Model 53-5480, and the Custom El Camino, Model 55-5680. Differences between the two base models are comprised of exterior trim and interior trim and equipment. Each base model is available with either a 6 or 8-cylinder engine, which determines the number prefix of the model number. Six-cylinder engine models have odd-number prefixes (53 or 55), whereas 8-cylinder engine models have even-number prefixes (54 or 56). A V-emblem on the lower rear portion of the front fenders identifies 8-cylinder engine models.

Styling, body construction, and chassis design of the El Caminos are basically those of the 1964 Chevelle passenger car line. Pertinent details are given in the section of this book entitled "The El Camino."

Entirely new also for 1964 are four forward control vans designated the Step-Van King's. They are Models P2535 and P3535 of 125-inch wheelbase and Models P2635 and P3635 of 137-inch wheelbase. Compared to the carryover forward control vans, the new models feature improved visibility as well as greater cubic capacity.

The 125-inch wheelbase Step-Van King's have a nominal body length of 10 feet; 137-inch wheelbase models have a nominal body length of 12 feet. Interior body height is 72 inches for all four models. Two optional body lengths of 10-1/2 and 12-1/2 feet and an optional interior body height of 76 inches expand body size choice to eight different bodies. Body styling is similar to the square-front design of the carryover Series P10 Step-Van 7's. Chassis components are identical to the carryover Series P20 and P30 models of 125 and 137-inch wheelbase as are Gross Vehicle Weight ratings.

The three new Low Cab Forward diesel tandems -- Model W8303 of 145-inch wheelbase, Model W8503 of 163-inch wheelbase, and Model W8803 of 181-inch wheelbase -- are essentially the same as the 1964 Series E80 models except for an Eaton-Hendrickson tandem rear suspension. The suspension, with a bogie rating of 30,000 pounds, is identical to that used on Series M80 models except for a 5.57 rather than a 7.17-to-1 rear axle ratio. Available optionally is a 34,000 pound bogie with a 6.50-to-1 axle ratio. The 163-inch wheelbase of Model W8503 and the 181-inch wheelbase of Model W8803 are new to the Chevrolet wheelbase line-up. Base GVW is 30,000 pounds, while maximum GVW is 36,000 pounds.

Several changes occur in the 1964 Gross Vehicle Weight ratings, the most significant being the release of an optional 21,000 pound maximum GVW plate for all Series 60 vehicles except cowls and Model L6503. Minimum mandatory equipment for the 21,000 pound GVW rating includes in all cases a 7000-pound capacity front axle with

3500-pound capacity (each) front springs; 8750-pound capacity (each) rear springs also are required for CLT60 models, whereas D60 models require rear springs of 11,500-pound capacity (each); also required for CL60 models only is RPO F03, Heavy-Duty Frame Equipment.

A new GVW rating of 15,000 pounds is released for Series S50 models in addition to the carryover ratings of 10,500 pounds (base); 14,000 pounds; and 16,000 pounds (maximum). Minimum mandatory requirements are the same as those for the 16,000 pound GVW rating. Due to the discontinuation of the 8-22.5-8 tire for Series M80 models, base GVW for these models is changed from 24,000 to 30,000 pounds, using 9-22.5-10 tires.

Other equipment changes for 1964 include the discontinued requirement of 4500-pound capacity (each) front springs on Series T60H and CLT80 models as a mandatory option for the 23,000 pound GVW rating. Also, due to the release of the 5000-pound capacity front axle and 3000-pound capacity (each) front springs as base equipment for Series T60 models, the 7000-pound capacity front axle and 3500-pound capacity (each) front springs, formerly base equipment, are no longer required to obtain the base 15,000 pound, optional 17,000 pound, and optional 19,500 pound GVW ratings.

The 1964 Chevrolet truck model line-up story includes several important model additions made during the 1963 model year -- the Series M60 trailing axle tandem models and the Series T69 tilt-cab models. These are discussed further in the section of this book entitled "Interim 1963 Changes."

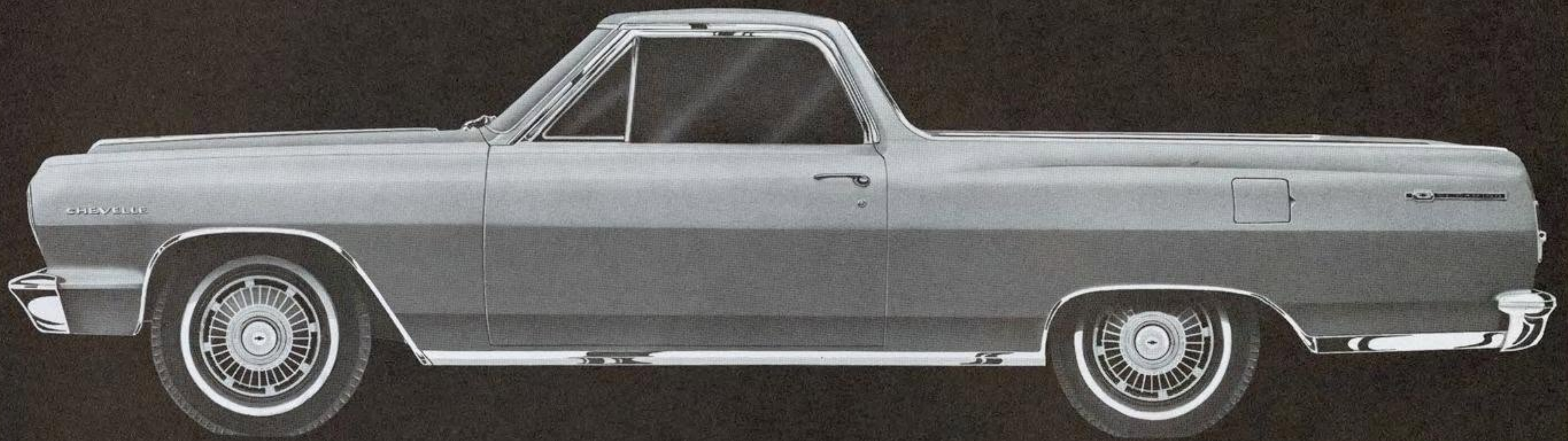

EL CAMINO SEDAN PICKUP MODEL 5580

The high cubic capacity bodies of the regular production Step-Van King's are available in two nominal lengths – 10 feet for Models P25,3535 of 125-inch wheelbase and 12 feet for Models P26,3635 of 137-inch wheelbase. With an interior body height of 72 inches, these body lengths provide a cubic foot capacity of 375 and 480, respectively. Two optional body lengths of 10-1/2 and 12-1/2 feet and an optional interior body height of 76 inches expand total body choice to eight different bodies.

Bodies feature all-steel construction, welded and bolted for maximum strength. The inner surfaces of the sides and roof are sprayed with mastic and lined with one-inch fiber glass pads for sound deadening and insulation against heat and cold. Steel panels line the body interior, providing a smooth surface that is both durable and practical. Corrugated steel is used for the cargo floor. The underside of the body is fully undercoated.

Easy entry and exit are afforded with sliding side doors of double-wall construction. Double rear doors of 38-inch width are standard, while 60-inch and 74-inch wide rear doors are offered as options.

Addition of the Step-Van King regular production and optional bodies to the Chevrolet model line-up along with new optional bodies for carryover Step-Van's (see Body section) affords a choice of 21 different body sizes for Step-Van customers.

NEW STEP-VAN KINGS

MODEL P2535 SHOWN.



Addition of three new tandem axle models to the Chevrolet model line-up expands to nine the number of tandem models available in 1964, affording not only both diesel and gasoline power, but also both conventional and LCF bodies and both conventional and trailing axle tandem suspensions.

Powered by the 6V-53 Detroit Diesel engine, the new models – designated as the W80 Series – are of Low Cab Forward body design with a conventional Eaton-Hendrickson tandem rear suspension rated at 30,000 pounds capacity. Front end sheet metal styling is identical to the carryover Series E80 vehicles.

Three wheelbases are offered: The 145-inch wheelbase of Model W8303; the 163-inch wheelbase of Model W8503; and the 181-inch wheelbase of Model W8803. The latter two wheelbases are new to the Chevrolet wheelbase line-up. Base Gross Vehicle Weight rating is 30,000 pounds; maximum GVW – the only optional rating – is 36,000 pounds. Details of the chassis and power train are given in other sections of this book.

NEW LCF DIESEL TANDEMS

MODEL W8503

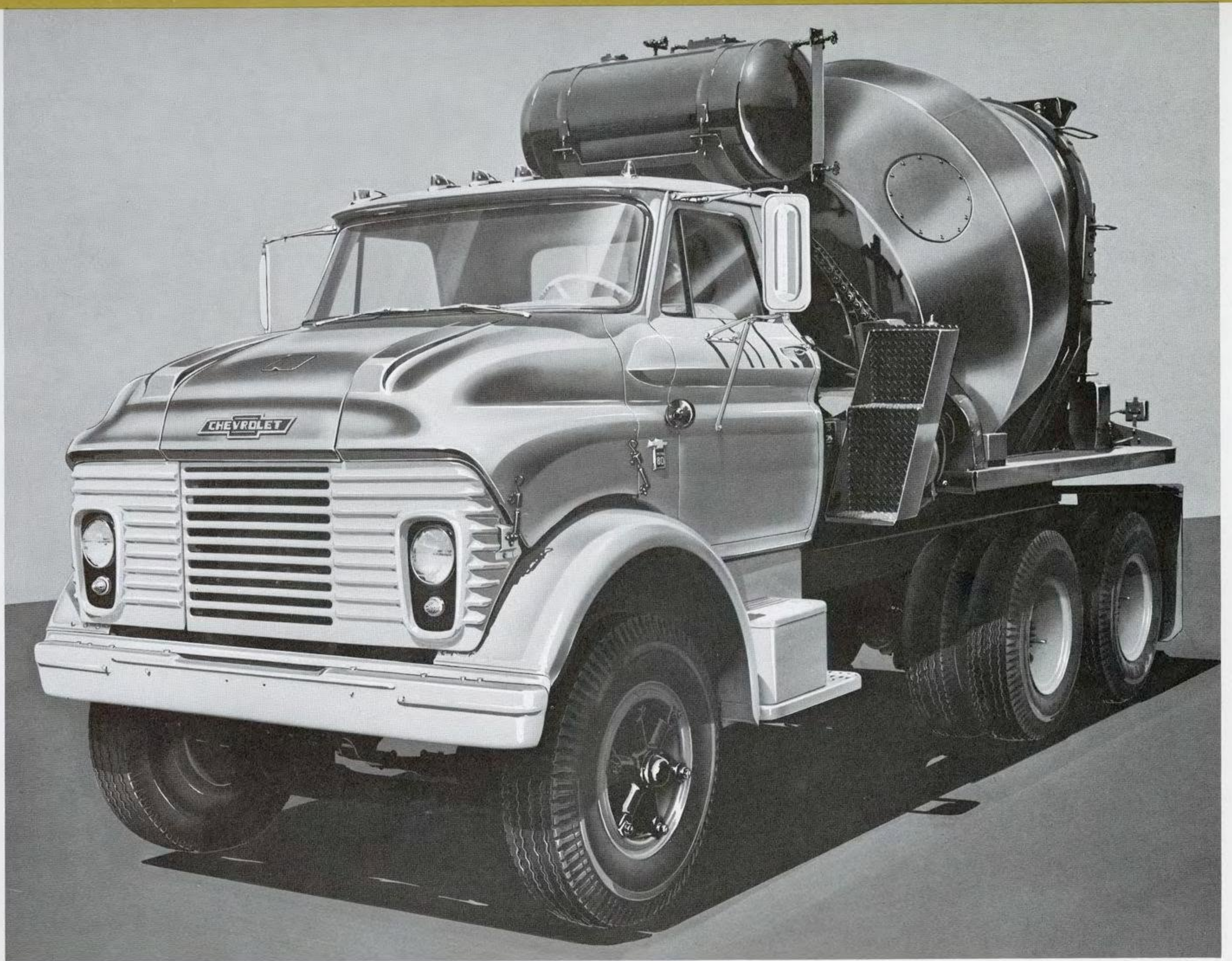

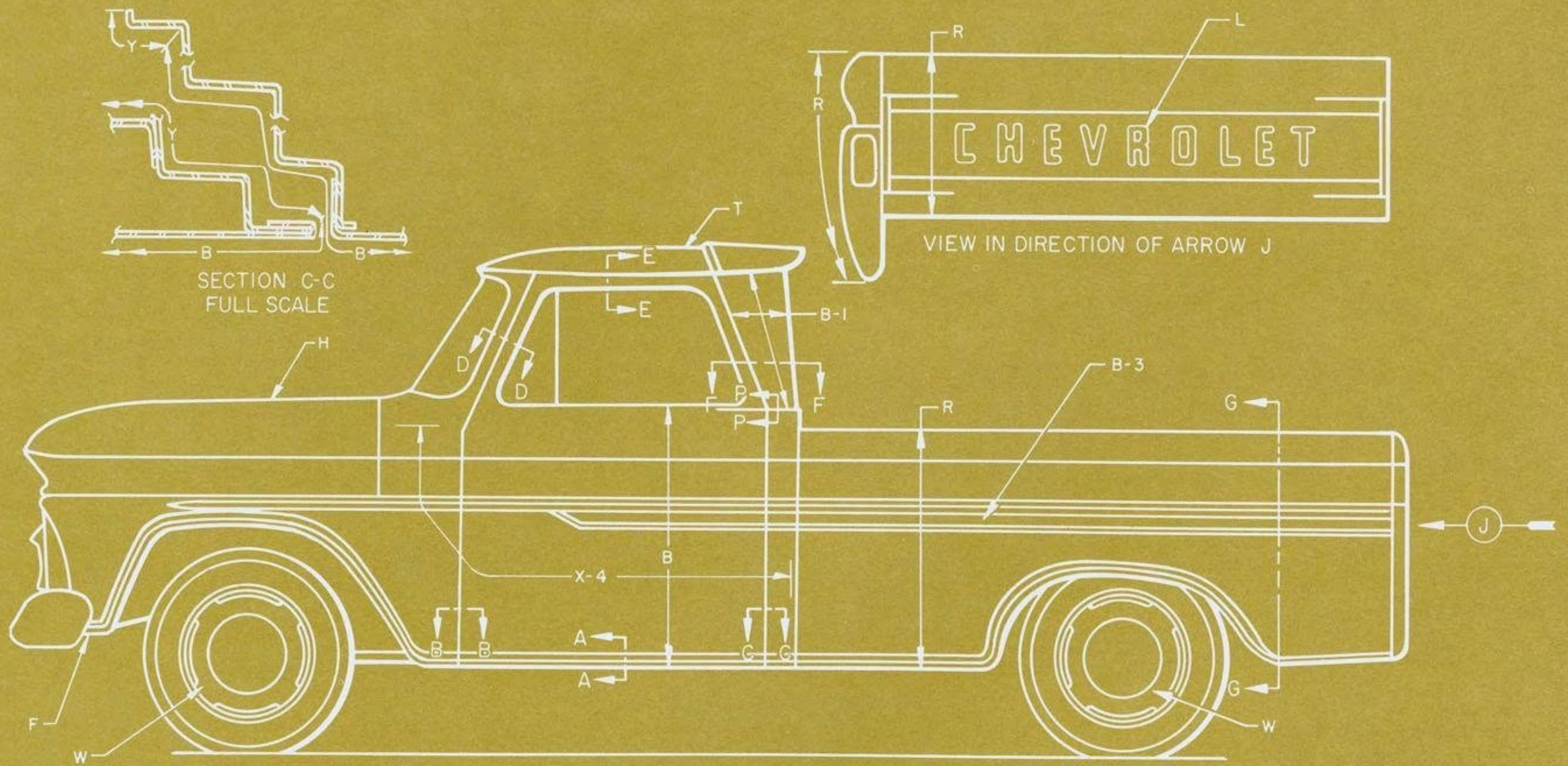

- ◆ NEW SIDE APPEARANCE, CONVENTIONAL LINE
- ◆ NEW RADIATOR GRILLES, HUB CAPS
- ◆ NEW SERIES DESIGNATION PLATES
- ◆ NEW EXTERIOR COLORS
- ◆ NEW INTERIOR TRIM
- ◆ NEW INSTRUMENT PANEL, DOOR INNER PANELS

styling

EXTERIOR STYLING

Model appearance for the conventional line is considerably changed on the exterior as evidenced not only in the revised front door opening for conventional cabs, LCF cabs, and single-unit bodies, but also in newly-styled components such as radiator grilles, hub caps, and series designation plates. The Corvair 95 line exterior is carried forward except for new hub caps.

NEW RADIATOR GRILLE STYLING. Radiator grilles for conventional cabs and single-unit bodies, conventional LCF's and tilt-cabs are new for 1964. One basic grille incorporating single headlights is offered with three variations - one for Series 10-30 models; one for Series 50-80 conventional models; and one for Series 60, 80 tilt-cab models.

Radiator grilles for Series P20, 30 round-front Step-Vans also are new for 1964, the former 3-bar design being supplanted by the 4-bar design used for Series P10 models. This change is necessitated by additional cooling requirements in optional 292 cubic inch engine installations.

Though diesel LCF radiator grilles are unchanged for 1964, front end appearance is modified somewhat with the addition of parking lights with white lenses below the headlights in the side access doors.

NEW HUB CAP STYLING. Corvair 95 models and Series 10-30 models, except those with 4-wheel drive, feature new hub caps with an embossed triple-spinner carrying an embossed Chevrolet trademark at the center. The hub caps are painted off-white except for the trademark background which is painted red. Chrome hub caps again are offered with the Chrome Bumper Equipment option. New accessory wheel trim disks also are offered for Corvair 95 models.

NEW SERIES PLATE STYLING. Excepting Step-Vans and tilt-cabs, all 1964 conventional line models carry new series designation plates. The chrome plates with a red-painted background for the series numerals are mounted approximately in the same location. Plates for diesel models incorporate the word "Diesel." Numerals, the word "Diesel," and the front face of the Chevrolet emblem have a satin rather than a bright chrome finish.

NEW CUSTOM CAB TRIM PLATE. Cab models with the Custom Appearance option are distinguished in 1964 by a new trim plate

for the body upper rear quarter area. The new plates carry straight horizontal embossments filled with black paint and the word "Custom" in black script at the center.

EXTERIOR COLORS. Fourteen exterior colors again are offered in 1964. Six of the colors are new, while the remaining eight are carried forward from 1963.

To clarify color identification, all 1964 colors are identified by their tonal value rather than by a descriptive name. Thus, for example, Balboa Blue (a carryover dark blue) is identified in 1964 as Dark Blue. Listed below are the 1964 colors with their 1963 counterparts.

New colors for 1964 are Light Blue (replaces Brigade Blue); Turquoise (replaces Crystal Turquoise); Light Green (replaces Glenwood Green); Gray Green (replaces Seamist Jade); Gray (replaces Georgian Gray); and Fawn (replaces Desert Beige). Turquoise and Gray Green are metallic colors.

Carryover colors are Dark Blue (formerly Balboa Blue); Dark Green (formerly Woodland Green); Black (formerly Jet Black); Orange (formerly Omaha Orange); Yellow (formerly Yuma Yellow); Red (formerly Cardinal Red); White (formerly Pure White); and Off-White (formerly Cameo White).

Two-tone combinations and method of 2-toning are carried forward from 1963 unchanged. The new Step-Van King models are 2-toned in the same manner as the carryover Series P10 models.

The Fleetside pickup model shown at the right typifies the new look of the 1964 conventional line. Most apparent of the changes, perhaps, is the new front door opening with its forward-slanting windshield pillar. The model shown also exhibits a new radiator grille, new hub caps, a new series designation plate, and a new Custom trim plate for the upper cab rear quarter area.





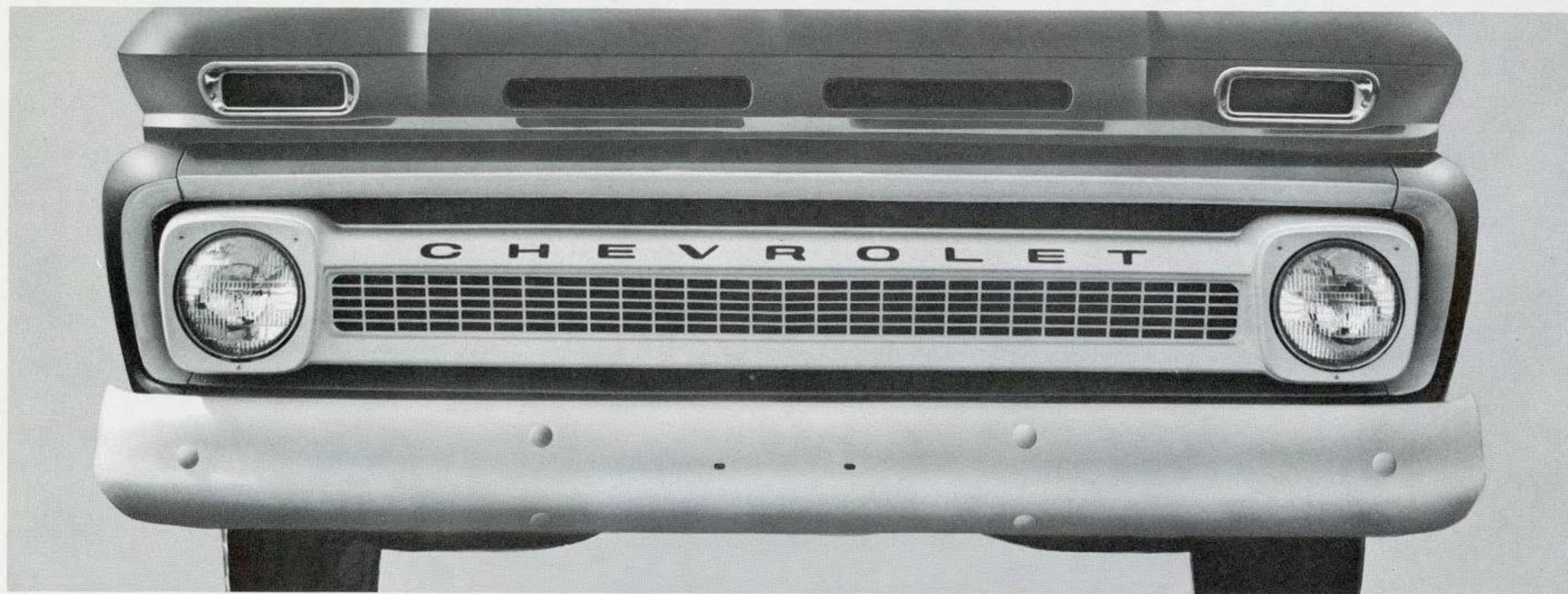

NEW RADIATOR GRILLE DESIGNS

Three variations of a basic radiator grille – all with single headlights – are offered for the 1964 conventional line.

In the Series 10-30 conventional cab and single-unit body applications, shown above, the air intake area is square-pierced for a screen effect. For Series 60, 80 tilt-cab models, shown at the upper right, the air intake screen is eliminated and replaced with a central Chevrolet trademark. The trademark is retained in the Series 50-80 conventional cab and LCF applications, shown at the lower right,

but the Chevrolet lettering surmounts the upper header bar rather than being carried directly on the bar.

All radiator grilles, including headlight doors, are painted Off-White; trademarks are Off-White with a Red field; lettering is Black, except in the Series 50-80 conventional cab and LCF applications where Off-White lettering is used. Custom Appearance Equipment-equipped Series 10-30 models continue to use a silver anodized aluminum radiator grille with Black lettering.

TILT-CAB

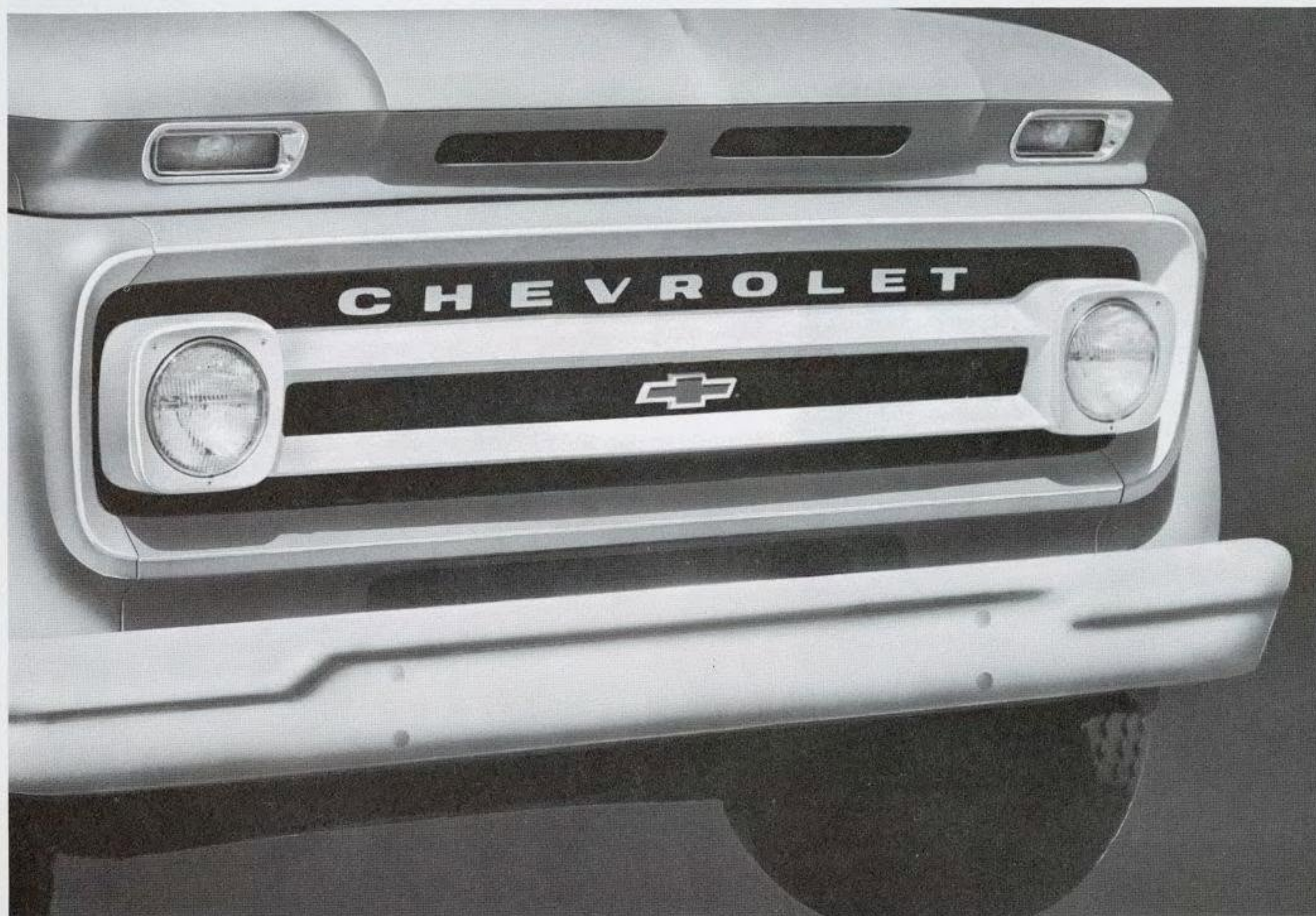

MEDIUM AND HEAVY-DUTY
CONVENTIONAL AND LCF

NEW HUB CAP DESIGN



New triple-spinner styling with a Chevrolet trademark motif imparts a distinctive look to the hub caps used for Series 10-30 models, including Corvair 95's. The hub caps are painted Off-White with a Red background for the trademark. Chrome plating replaces the Off-White areas when the Chrome Bumper Equipment option is specified.

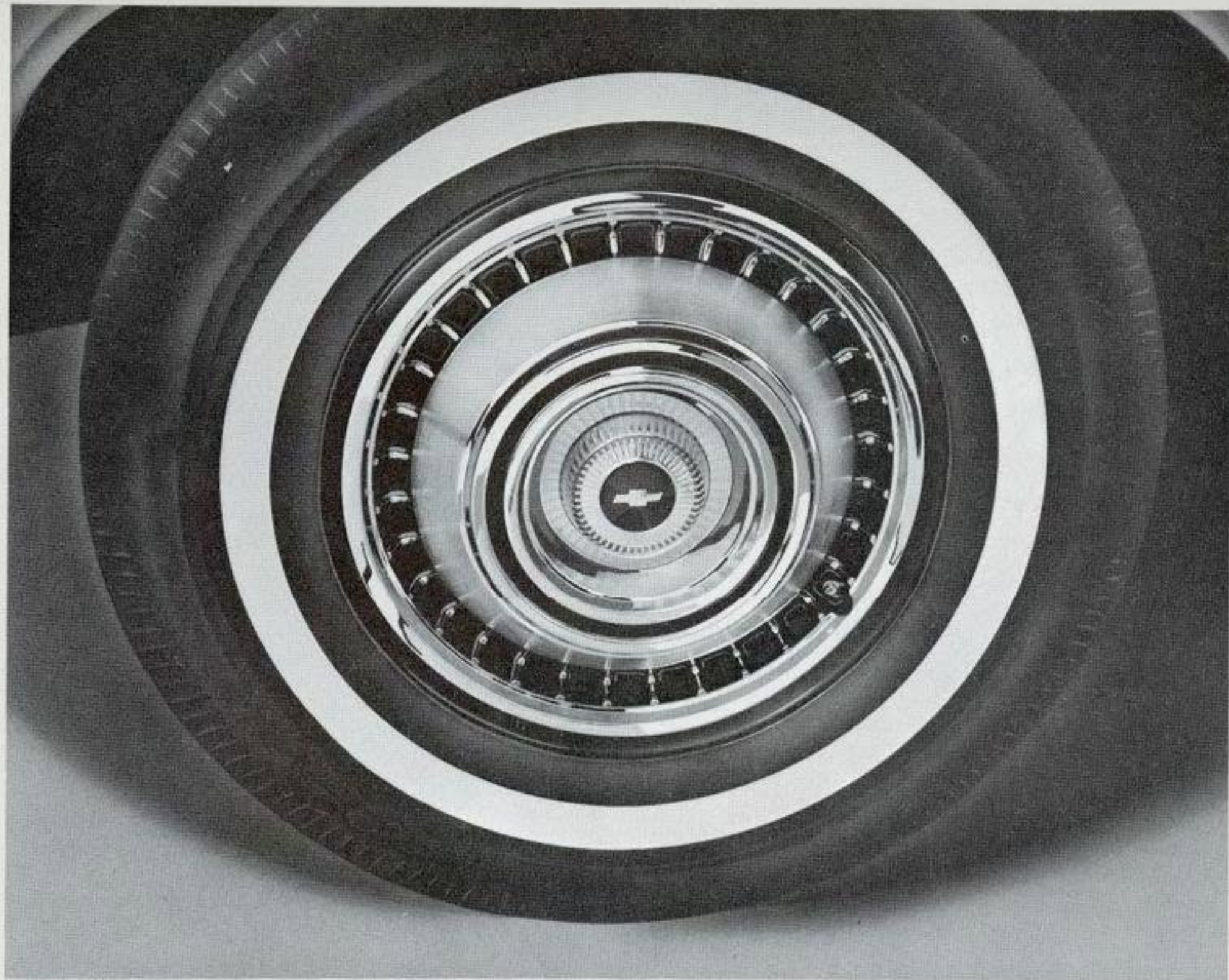

NEW
CORVAIR 95
ACCESSORY
WHEEL TRIM
DISK

New, extra-cost accessory wheel trim disks contribute handsomely to the exterior appearance of Corvair 95 models. Fabricated of polished stainless steel with Black painted decoration, the disks carry a cone-type plastic emblem insert having Black, Silver, and chrome accents.



Large chrome series designation plates of new design with a Red-painted background for the series numerals are featured for all conventional line models except Step-Van's and tilt-cabs. The plates are mounted approximately in the same locations as their predecessors. Numerals and the front face of the Chevrolet trademark have a satin rather than a bright chrome finish.

NEW SERIES DESIGNATION PLATES

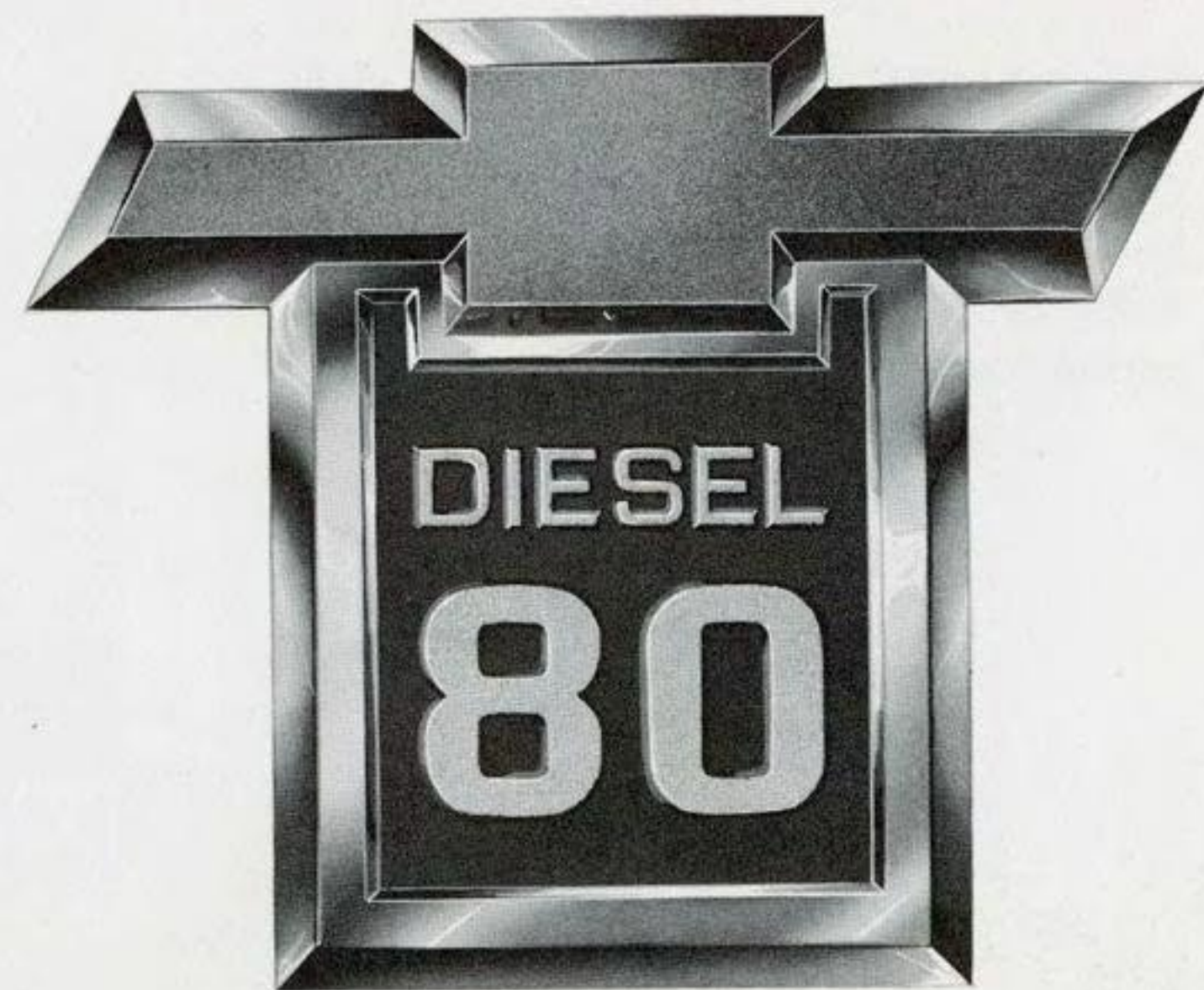

Plates for diesel engine models incorporate the word "Diesel" in a satin chrome finish. Other aspects of the plate remain the same as those for gasoline engine models.



NEW CUSTOM CAB TRIM PLATE

Simply-styled, new body upper rear quarter trim plates distinguish Series 10-30 cab models with the Custom Appearance Equipment option. The polished stainless steel plates carry black paint fill between the embossments and in the depressed script at the center.

INTERIOR STYLING

As an outgrowth of the revised door opening structure, conventional line bodies feature several significant interior changes. New styling is employed not only for the instrument panel and its related components, but also for the front door inner panels. Along with new seat trims, these changes impart a fresh, new appearance to the conventional line interiors. Corvair 95 models, too, feature new seat trims as well as new trim plates for the instrument cluster and dispatch box door.

INSTRUMENT PANEL design for 1964 conventional line models except tilt-cabs, flat face cowls, and Step-Van's is completely new, including the clusters, controls, cover plates, ash tray, and dispatch box door. A dispatch box door trim plate carrying the word "Chevrolet" is provided Series 10-30 models with the Custom Appearance Equipment option. Bright control knob trim also is provided these models.

Instrument panel control knobs are integral with the instrument cluster, and, as a safety precaution, are angle-mounted at the bottom of the cluster to contain them within the limits of the cluster recess in the instrument panel. The cluster recess forms a hood over the cluster, assuring good instrument readability. A honed plastic cluster lens again is used to eliminate reflections.

Both light and heavy-duty type clusters again are offered, with the heavy-duty cluster available optionally for Series 10-30 models. Though newly-styled, control and instrument type for

both clusters is unchanged. Featured for 1964, however, are two direction signal lights and a new highbeam indicator which shows the word "Bright" in red when lighted.

Corvair 95 instrument cluster design is carried forward from 1963 unchanged except the 4-speed transmission shift points are eliminated from the speedometer face and the cluster carries a new anodized aluminum trim plate.

INNER DOOR PANEL. Front door inner panels for all conventional line models except tilt-cabs and Step-Van's are restyled for 1964. The window regulator and lock release handle are carried forward from 1963.

For Series 10-30 models with the Custom Appearance option, the removable upper panel is 2-toned with Off-White.

SEAT TRIM designs for all Corvair 95 models and all conventional line models except Step-Van's, tilt-cabs, and diesel LCF's are completely new. All-vinyl trim again is featured for the regular production seat. The embossed coverings are Medium Fawn, while the facings are Light Fawn.

Custom seats again feature nylon-faced pattern cloth for the coverings and vinyl for the facings and bolsters. The striped coverings are basically Medium Fawn; facing and bolster color (Medium Fawn or Red) is dependent upon exterior color, as it was in 1963. The lower top bolster again is White.

The new look of the conventional line interiors is evidenced immediately upon the opening of the front doors. Door inner panels have a new styling configuration which keynotes the tasteful simplicity of the entire interior.

Illustrated is the special 2-tone paint treatment given door inner panels of Series 10-30 models with the Custom Appearance Equipment option. In this application, the Fawn-colored door is highlighted with Off-White on the removable upper panel.





INTERIOR STYLING

REGULAR PRODUCTION INTERIOR

Other than the new instrument panel and front door inner panel designs, which are applicable to all conventional line models except Step-Van's and tilt-cabs, the most distinguishing feature of the regular production interior is the new seat trim shown on the opposite page in the panel model application.

Both the coverings and facings are Seville leather grain vinyl, affording an all-vinyl trim for easy maintenance and good durability. The Medium Fawn embossed coverings and Light Fawn facings restate the Fawn interior color scheme. Corvair 95 models also feature the new seat trim design.



INTERIOR STYLING



CUSTOM INTERIOR

Shown on the opposite page is the new Custom interior as it applies to a Suburban Carryall model. Both Custom Appearance Equipment and Custom Comfort and Convenience Equipment features are illustrated.

New or restyled Custom Appearance Equipment items – restricted to Series 10-30 models – are the dispatch box door trim plate, bright control knob trim, and 2-tone door panel paint treatment. The special steering wheel with chrome horn ring is carried forward from 1963.

Restyled Custom Comfort and Convenience Equipment items are the cigar lighter and seat trim. The seat coverings are nylon-faced pattern cloth in shades of Medium and Dark Fawn with Red, White, and Gold accents. Seville leather grain vinyl facings and bolsters complete the new seat trim. Except for the lower backrest bolster, which remains White in all cases, facing and bolster color is dependent upon exterior color, with Red used for White, Off-White, Red, and Gray exteriors and Medium Fawn used for all other exterior colors.

INTERIOR STYLING

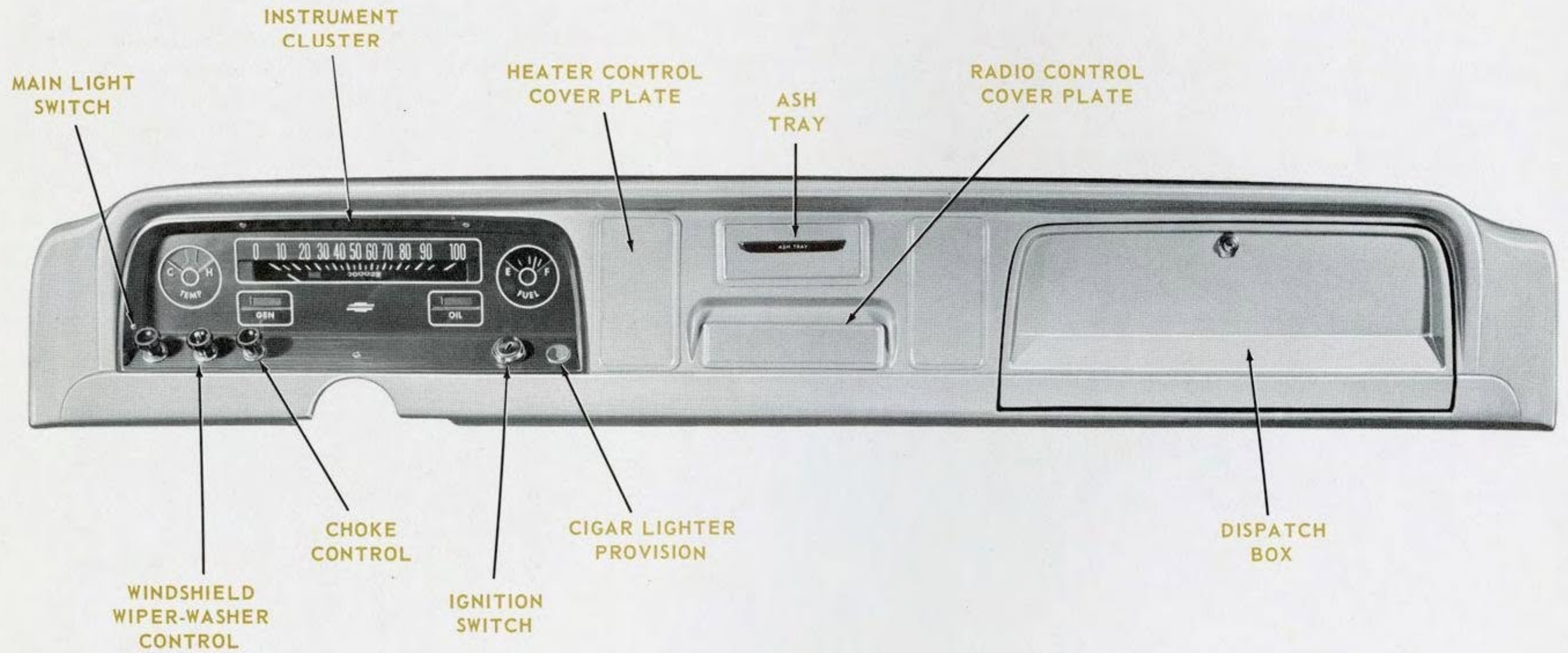

INSTRUMENT PANEL DESIGN

Excepting tilt-cabs, flat face cowl, and Step-Van's, conventional line models feature a handsome, new instrument panel painted Fawn to match the interior color. Illustrated is the regular production panel with a light-duty instrument cluster.

Both light and heavy-duty clusters again are offered, with the heavy-duty cluster – shown below – available optionally for Series 10-30 models. Instrument type for both clusters is unchanged, the principal difference between the two clusters being the use of warning lights rather than gauges for the light-duty cluster. Innovations in the 1964 cluster designs are the incorporation of the instrument panel controls with the cluster assemblies, the use of left and right

hand direction signal indicators, and a new high-beam indicator showing the word "Bright" in red when lighted. Good instrument readability is assured with the recessed cluster design and the use of a non-reflective cluster lens. Cluster faces and gauge dials are Charcoal with Light-Green markings, contributing further to good instrument readability. Cluster bezels are painted Charcoal.

Distinguishing Series 10-30 models with the Custom Appearance Equipment option is a trim plate for the dispatch box door and bright trim for the black plastic control knobs. A cigar lighter with bright trim is provided all models with the Custom Comfort and Convenience Equipment option.

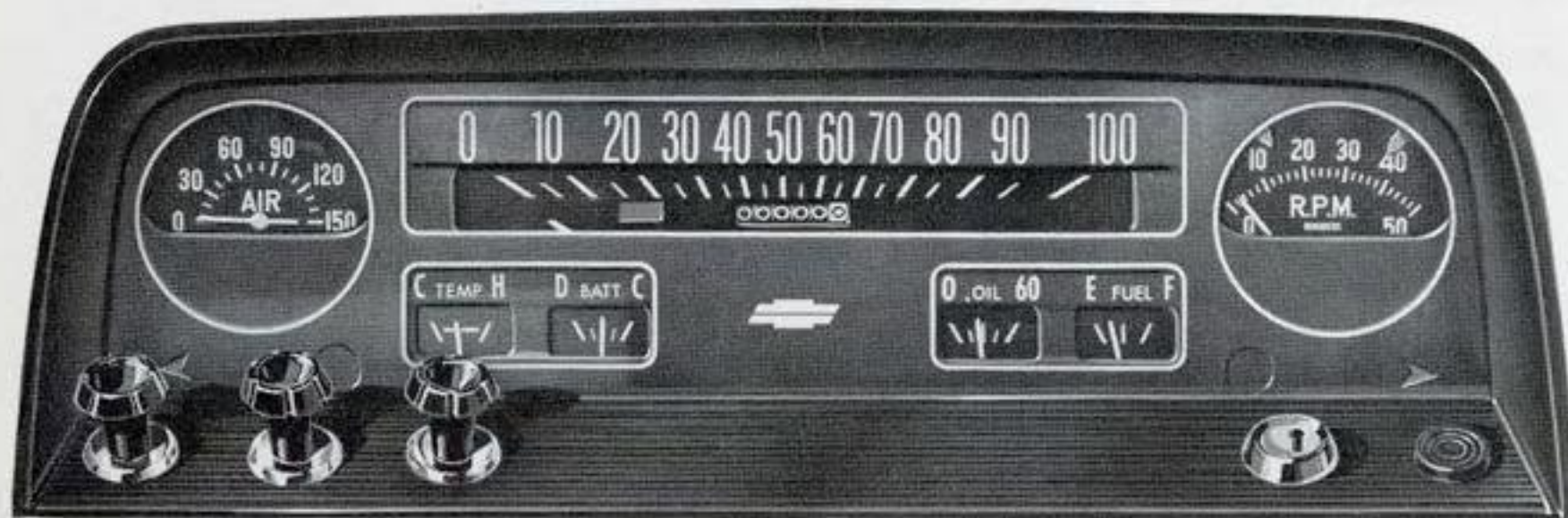

Illustrated is the new heavy-duty instrument cluster released as standard equipment for Series 50-80 models and as an option for Series 10-30 models. In this design, gauges rather than warning lights are used to indicate engine temperature, battery charging, and oil pressure. Provisions are made for an air brake pressure gauge and a tachometer, shown installed. The unit also incorporates provisions for a tandem axle lock-out warning light as well as an overspeed warning light.

CUSTOM DETAILS

Custom details highlight the instrument panels of both conventional and Corvair 95 line models, contributing further to the new interior appearance of the 1964 trucks.



Bright trim decorates the new-design instrument panel control knobs of conventional line Series 10-30 models with the Custom Appearance Equipment option. The main body of the control knobs is black plastic. Control knob design and trim are utilized for the cigar lighter provided in the Custom Comfort and Convenience Equipment option.

New for 1964 is the dispatch box door trim plate provided with the Custom Appearance Equipment option. The plate, fabricated of plastic, is painted a flat Charcoal; White paint delineates the raised Chevrolet lettering.

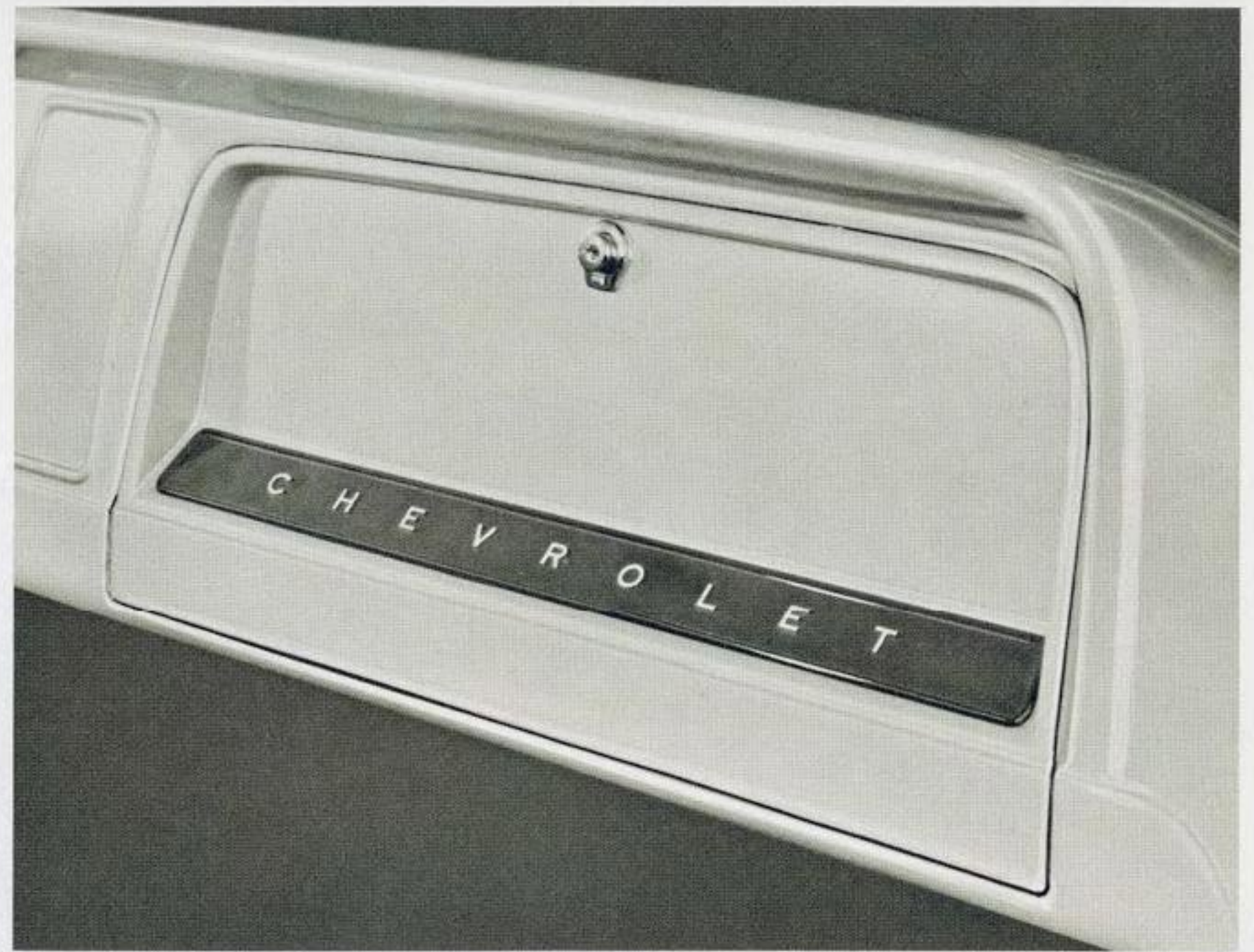

The Custom Equipment option for Corvair 95 models provides a silver anodized aluminum trim plate for the dispatch box door. The plate matches the trim plate on the instrument cluster.

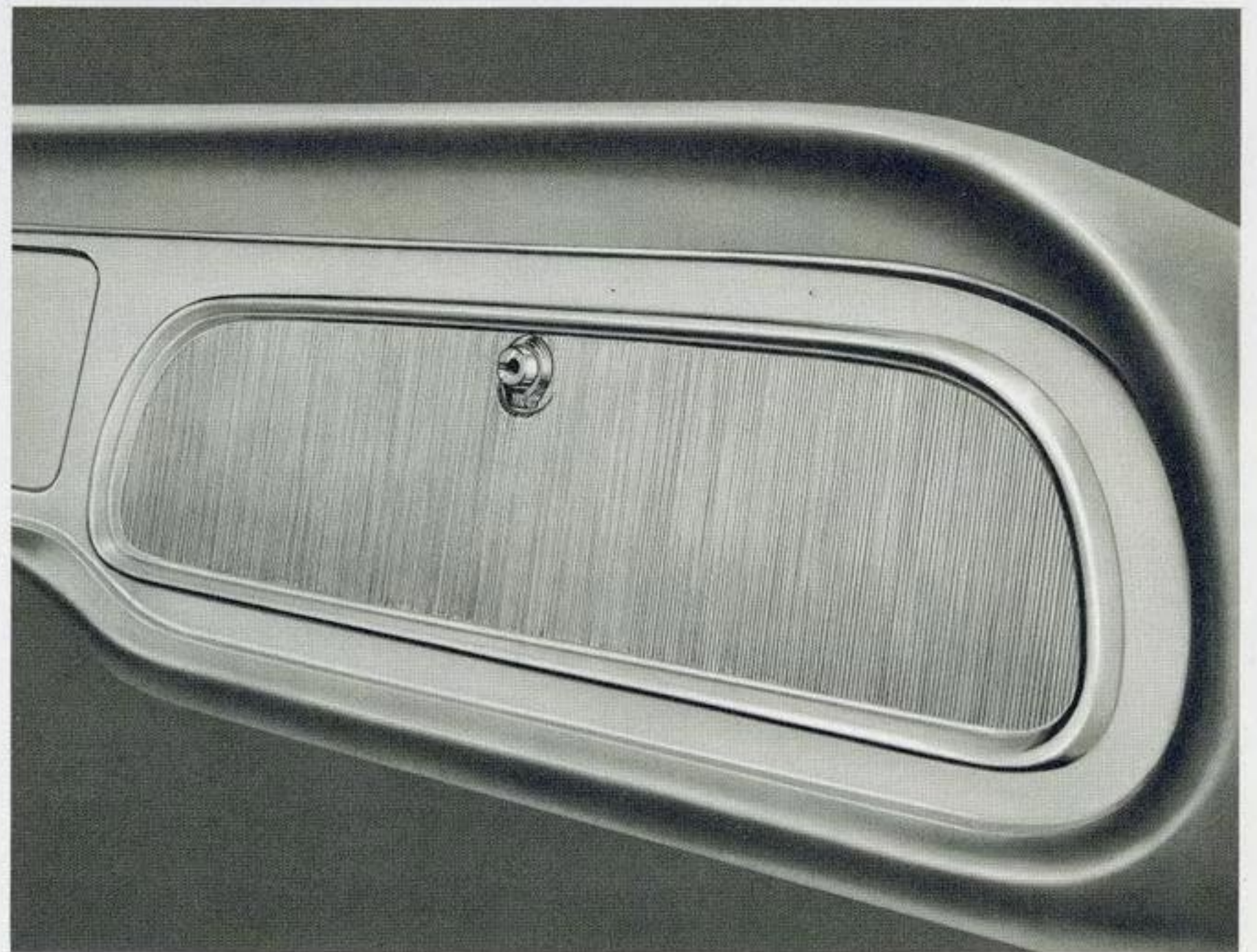

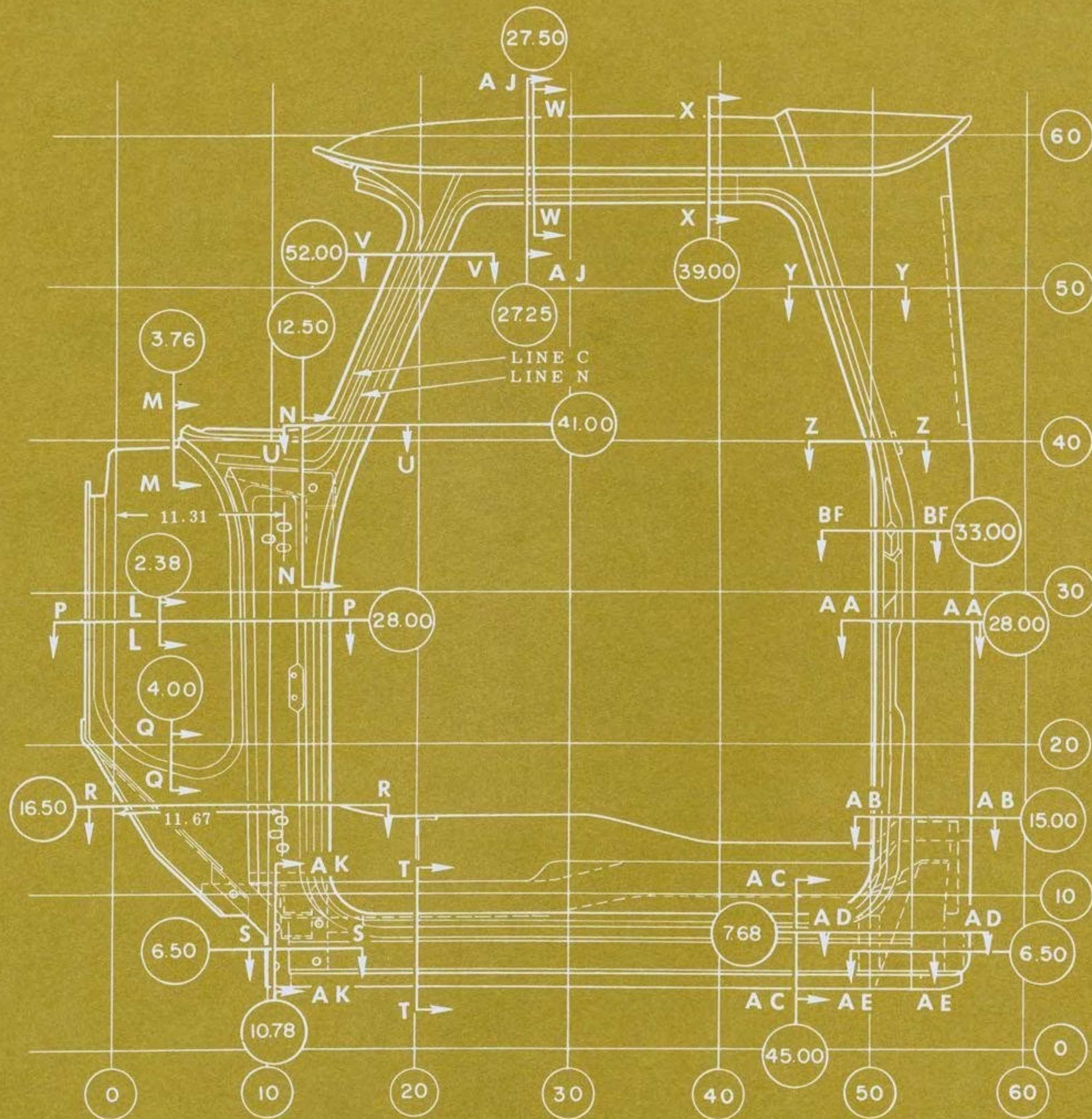

- ◆ REVISED DOOR OPENING
- ◆ IMPROVED INSULATION
- ◆ NEW FOAM SEAT CUSHION
- ◆ IMPROVED VENTILATION
- ◆ NEW ROTARY DOOR LOCKS
- ◆ OTHER SIGNIFICANT IMPROVEMENTS

body

BODY

Conventional line bodies for 1964 feature many new improvements, the most significant being a new front door opening structure which eliminates the former hinge pillar dog-leg for improved driver compartment entrance and egress. Other new body features for 1964 include improved front door locks, improved interior ventilation, improved inside fuel tank mounting, improved windshield retention, more durable regular production seat cushion construction, lower transmission tunnel for Series C10, 20 models; improved front body mounts for most Series CK10 models; and new sound deadening and insulation materials.

Corvair 95 body structures, though generally carried forward from 1963, feature several noteworthy improvements including a new engine access door with recessed license plate mounting and lighting and new underbody splash shielding.

REVISED DOOR OPENING. In eliminating the former dog-leg in the front door opening to assure unobstructed entry and exit, the essential change is concentrated in the area of the hinge pillar. The front doors and the windshield structure, of course, also are affected.

Single-unit construction is employed for the new hinge pillars, replacing the former 2-unit construction for increased pillar strength. An additional gain in pillar strength is afforded with the use of 0.0598 inch gauge metal for the full length of the pillars. Previously, metal gauge of the pillars varied between the upper and lower sections from 0.0359 inch to 0.0598 inch, respectively. These gains in hinge pillar strength provide not only stiffer windshield and front door openings, but also a torsionally more rigid overall body structure.

An outgrowth of the new hinge pillar design is an increase in flange height where the outer pillars are joined to the inner pillars in the windshield opening area. These along with similar increases in flange size at the top and bottom of the windshield opening provide a larger lip for more secure anchoring of the windshield weatherstrip, improving windshield glass retention even under extreme body beaming.

Another outgrowth of the new hinge pillar design is afforded with the incorporation of a gutter on the upper portion of the pillar and the addition of holes in the roof panel gutter just ahead of the hinge pillar. Formerly, holes in the roof panel gutter at the rear afforded the only means of water drainage.

Because of the new front door opening structure, conventional cab and single-unit body windshield and front door glass visibility

areas are revised. Windshield visibility area decreases 148.1 square inches. Side window visibility area increases 70.9 square inches for each window, while ventipane visibility area decreases 2.18 square inches for each ventipane.

NEW SOUND DEADENING AND INSULATION MATERIALS in both regular production and optional Custom Comfort applications are employed for all conventional line body types except Step-Van's and tilt-cabs.

Considerable gains in the reduction of interior compartment noise level and temperature extremes are achieved with the use of a new floor panel insulator under the floor mat, an improved dash panel insulator, and sprayed mastic for the front door outer panels. The floor insulator is comprised of an 0.31-inch thick mastic pad bonded to an 0.25-inch thick polyethylene foam pad. Cemented in place, the insulator covers the entire front compartment floor panel, including the toe area of the dash and toe panel. Transmission access covers also are insulated. The dash panel insulator consists of a woven cotton fiber pad 0.75-inch thick bonded to a hardboard face panel; the new pad replaces the former 0.50-inch thick fiber glass pad. Door insulation consists of five pounds of mastic deadener sprayed over the entire inner surface of each front door outer panel.

Added to the optional Custom Comfort and Convenience package for C-K-L-M models is an 0.50-inch thick woven cotton fiber pad for the underside of the cowl plenum chamber. Additionally, the perforated-type dash panel insulator is no longer used in the Custom Comfort package because of the new and improved regular production insulator, and cab models are no longer equipped with asphalt-impregnated pads for the body rear panel.

Interior compartment comfort also is improved with the increased heater efficiency achieved with the hardboard fuel tank insulator included with factory installations of the Deluxe accessory heater; the hardboard insulator also helps to reduce interior compartment noise level.

NEW SEAT CUSHION CONSTRUCTION. Regular production seat assemblies for both the conventional and Corvair 95 lines feature new, more durable construction for the cushion. The former polyurethane foam pad, cotton batting, and burlap-wire spring cover are replaced with one pad of molded polyurethane foam bonded to burlap. Durability is achieved through the simplification of the padding itself and the subsequent elimination of production

variance inherent in multi-unit assembly. Seat cushion pad thickness is 1.75 inches.

The change in seat cushion construction also is applicable to Custom seats for Suburban Carryall and Corvair 95 models. In these applications, trim material and the addition of a 3/4-inch polyurethane foam pad to the backrest assembly comprise the only differences between the regular production and Custom seats. Custom seat construction for conventional line cabs remains unchanged.

NEW LOCK PILLAR AND LOCK DESIGNS. Conventional line bodies feature a new lock pillar design wherein the former guide for the lock alignment wedge on the door is eliminated. No wedge guide is needed in the 1964 pillar design since the method of aligning the lock with the lock striker is achieved through a new door lock having the alignment wedge integral with the lock striker.

The new front door locks, which replace the former cam-type locks, are of the rotary-gear type, and feature improved locking ability for greater safety, along with faster lock action for decreased door closing effort. When the door is closed, the lock rotor cover extends beyond the striker plate both at the top and at the bottom, doubling contact area when stressed for more positive door retention. Faster lock action is inherent in the new design since the lock rotor simply rotates into engagement with the striker teeth as the door is closed, resulting in decreased door closing effort. In the previous design, lock action was not as fast because of the greater distance traveled before the cam-type lock bolt engaged the striker.

In actual operation, the lock rotor contacts the striker and rotates into engagement with the striker teeth. A spring-loaded nylon wedge at the top of the striker opening assures positive engagement of the rotor with the striker by bearing against the top of the rotor cover. If the door is only partially closed, the first tooth on the striker acts as a safety catch since a spring-loaded lever engages the lock rotor, locking the rotor to the striker tooth. Another tooth on the rotor is engaged when the door is fully closed.

IMPROVED INTERIOR VENTILATION is achieved for 1964 conventional line bodies through the use of deflectors on the cowl side air inlet valves for the direction of additional air to the floor panel. Detents are provided on the air inlet valve

handle guides to indicate when the valves are in the full-open position.

LOWER TRANSMISSION TUNNEL. A full-formed, or one-piece, dash and floor panel is released for Series C10, 20 models with the regular production 3-speed transmission or optional Power-glide transmission, reducing transmission floor tunnel height for increased foot room. The new dash and floor panel construction for the above models eliminates the former separate transmission access cover, dash and toe panel, and floor panel.

IMPROVED FRONT BODY MOUNTS. Softer ride, reduced noise, and increased durability are afforded through a redesign of the front body mount upper cushion for 1964 Series CK14-1503,04,34 and C1402,12 models. The essential change in design is a reduction in load rate of from 1000 to 750 pounds; cushion diameter also is reduced and upper and lower plates are now of the overhanging type. Lower cushion design of the front body mount is unchanged.

NEW FUEL TANK MOUNTING. Fuel tank durability is improved through a new mounting system for conventional line inside-mounted fuel tanks. In the new system, small brackets are welded to the cab rear panel near the top of the fuel tank, providing a higher point for securing the retaining straps at the rear. Front retention of the straps remains unchanged. This method of securing the fuel tank permits the retaining straps to pass only over the top and front of the fuel tank, alleviating stresses on the tank.

NEW STEP-VAN KING FEATURES. Bodies for the new P25, 3535 and P26, 3635 models feature all-steel construction, welded and bolted for maximum strength. Nominal body lengths of 10 and 12 feet are offered with 10-1/2 and 12-1/2 foot bodies available as regular production options. Two interior body heights are offered - the regular production 72-inch height and an optional 76-inch height. Accordingly, eight different size bodies are available.

The inner surfaces of the sides and roof are sprayed with mastic and lined with one-inch fiber glass pads for sound deadening and insulation against heat and cold. Steel panels line the body interior, providing a smooth surface that is both durable and practical. The body is fully undercoated.

BODY

Corrugated steel of 18-gauge is used for the cargo floor. A smooth floor of 11-gauge steel is available as a regular production option. Wheelhousings are rectangular for simplicity and safety in loading. An optional plywood partition with a right hand sliding section can be installed to close off the driver's compartment from the load space. A dome light for the rear compartment also is available as a regular production option.

The engine housing and its cover are double-wall constructed and lined with one-inch of fiber glass insulation. Rubber periphery seals at the top and bottom of the housing prevent entry of engine fumes. Simple snap fasteners permit quick removal of the housing for complete engine access. Convenient access doors simplify servicing the radiator, brake master cylinder, fuel tank, and battery.

Easy entry and exit is afforded with sliding side doors of double-wall construction. The front portion of the left hand door glass is movable; the right hand door glass is stationary, but movable glass is available as a regular production option. The left hand door is equipped with an outside handle and inside lock, while the right hand door has both inside and outside locking handles.

Double rear doors of 38-inch width are standard. Full-length hinges assure easy door action, while double-wall construction affords sturdiness. The left hand door has an inside latch at the top of the finger-pull type; the right hand door utilizes a latch which engages both at the top and the bottom and is operated with an inside opening handle and an outside key-locking handle. Both doors are equipped with glass. Sixty-inch wide rear doors of identical construction are available optionally. Also available optionally is a special rear end assembly with a 74-inch door opening width and four doors with full-length hinges which open outward and wrap around the body. The two center doors are equipped with glass. The 74-inch door opening width also is available with two doors having strap-type hinges. These doors also have glass.

Red vinyl coverings with black leather-grain are used to trim the cushion and backrest of the adjustable driver's seat. The seat can be adjusted fore and aft and up and down. For unobstructed access through the driver's door, the seat can be folded forward out of the way. An identical passenger seat is available as a regular production option.

Two-speed electric windshield wipers with 16-inch blades are provided as standard equipment. The windshield is of laminated

safety plate glass; other body glass is laminated safety sheet. Outside mirror type and location for both left and right hand mirrors is identical to Series P10 Step-Van's.

Body options not mentioned above are comprised of the following items: spare tire carrier; foam rubber padding for driver's seat; front and rear direction signal lamps; clearance lamps; heater and defroster; body revisions for dual rear wheel installations on P30 models; 7-1/2 inch, fixed-arm, right hand outside rear view mirror; 4 by 16-inch left and right hand outside rear view mirrors; fender extension for dual rear wheels; body in prime; marker lights; cluster bar lights; traffic hazard warning switch; tinted windshield glass; windshield washer. All body options for the new Step-Van King models are ordered under RPO E32.

STEP-VAN BODY CHANGES. Model P1345 - the Step-Van 7 - is carried forward from 1963 without change except for a new outside mirror placement to improve rearward visibility. Formerly mounted at the windshield header, the production mirror is now located forward on the front body side panel. Optional right hand mirror location also is changed from the windshield header to the top surface of the body front sheet metal.

Optional body equipment also is carried forward, but option availability is expanded to include 10 new items. Most significant of the new options are the 69-inch inside height and additional 12-inch body length; with the standard 7-foot nominal body length and 64-3/4 inch inside height, these new options provide a choice of four different body sizes.

Other new body options consist of the following: tinted windshield glass; passenger seat identical to driver's seat; cluster bar lights; marker lights; traffic hazard warning switch; sliding window for right hand front door; 4 x 16-inch left and right hand outside rear view mirrors.

Models P23,25,2645 and P33,35,3645 also are carried forward from 1963 without change, except for a new radiator grille design and several additions and deletions to the optional body equipment line-up.

For 1964, the 3-bar radiator grille design is replaced with the 4-bar design used for Series P10 models, affording improved cooling for optional 292 cubic inch engine installations. A new lower grille filler panel is used with the new radiator grille.

Most significant of the new body options are the new 72 and 76-inch inside heights with the 72-inch inside height option

including a vertical rear end and 65-inch rear door height. With the standard nominal body lengths of 8, 10, or 12-feet and the standard inside height of 68-1/2 inches, the new inside height options provide a choice of nine different body sizes.

Other new body options are comprised of the following: marker lights; cluster bar lights; traffic hazard warning switch; tinted windshield glass; sliding window for right hand front door; 4x16-inch left and right hand outside rear view mirrors; and windshield washer.

Options deleted for 1964 consist of the following: 38-inch wide solid rear doors; metal inserts in place of rear door glass; shutter-type louvers in place of rear door glass; left and right hand bakery-type side doors; right hand bakery-type door with sealed standard left hand door; theatre-type passenger seat; power roof ventilators, and extra tail lamp.

AIR INLET GRILLE SHUT-OFF DOOR. To ensure more effective front compartment heating with the Deluxe heater and defroster, a door is provided in the plenum chamber of all 1964 Corvair 95 models for preventing the flow of cold air through the air inlet.

The door, fabricated of polypropylene plastic, is attached to the body front panel directly behind the body air inlet grille. Self-hinging at the bottom, the door is actuated by a 2-position, spring-loaded handle located under the instrument panel at the direct center.

ENGINE ACCESS DOOR. The engine access door in the rear body sheet metal of all Corvair 95 models is redesigned to provide a recessed license plate mounting with overhead illumination, preventing damage to both the license plate and lamps. The license plate recess in the reinforced fiber glass door is offset to the left of the door vertical centerline. The release lever and hinges, though of the same basic type, also are redesigned.

UNDERBODY SPLASH SHIELD. The front end underbody of all 1964 Corvair 95 models carries a removable sheet metal shield which protects the clutch, brake, and accelerator controls from mud and water splash, preventing freeze-up of these components under severe cold weather conditions.

BODY

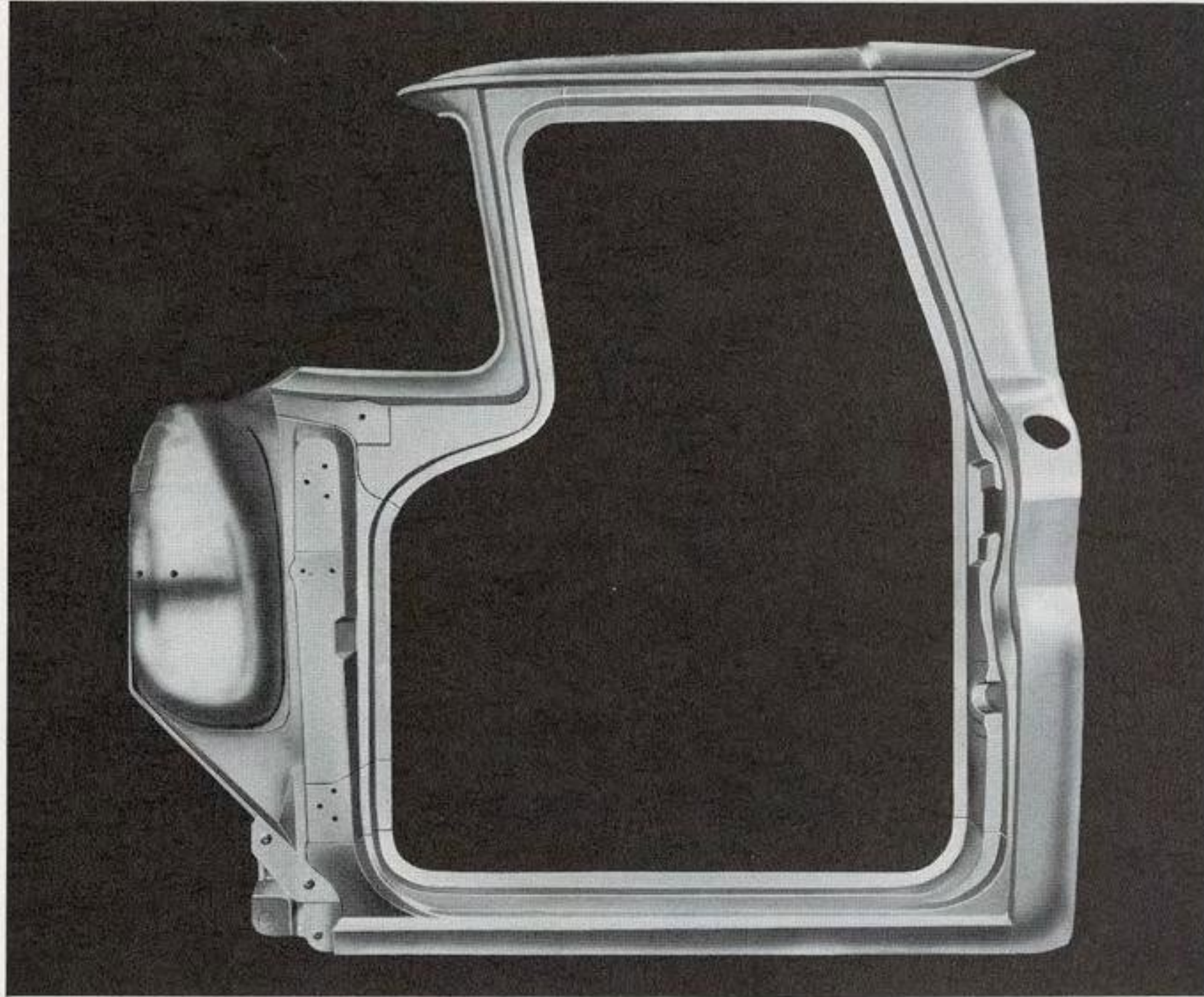

1963

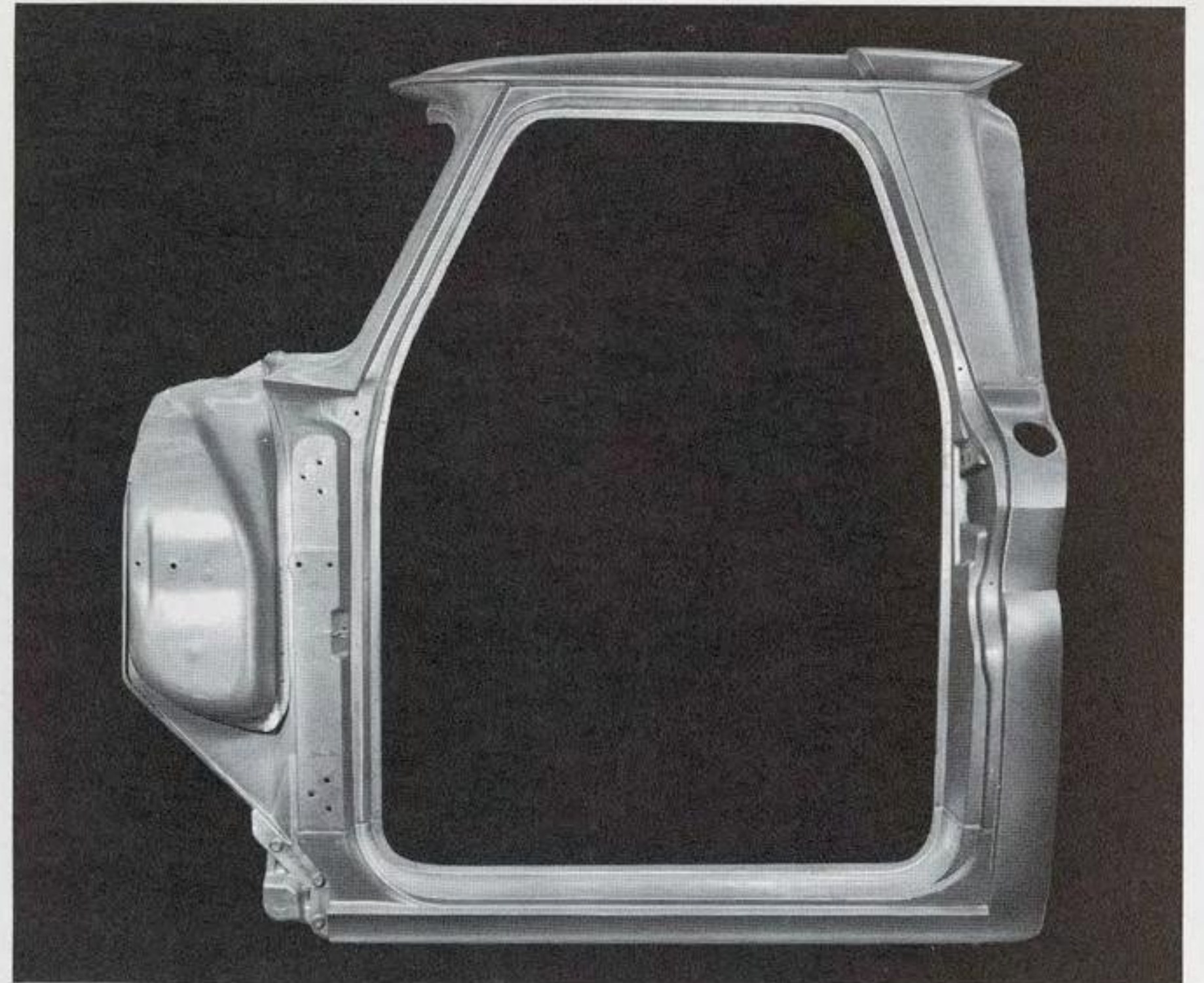

1964

As illustrated at the left, the 1964 conventional cab body structure contains no hinge pillar dog-leg above the belt line, affording an unobstructed front door opening for improved entry and exit.

Attendant benefits derived from the revision to the hinge pillars include increased torsional rigidity of the overall body structure through single-unit pillar construction and constant-gauge metal; improved water drainage from the roof through the incorporation of a gutter on the upper portion of the pillar; and increased windshield opening flange height for more secure anchoring of the windshield weatherstrip.

REVISED DOOR OPENING STRUCTURE

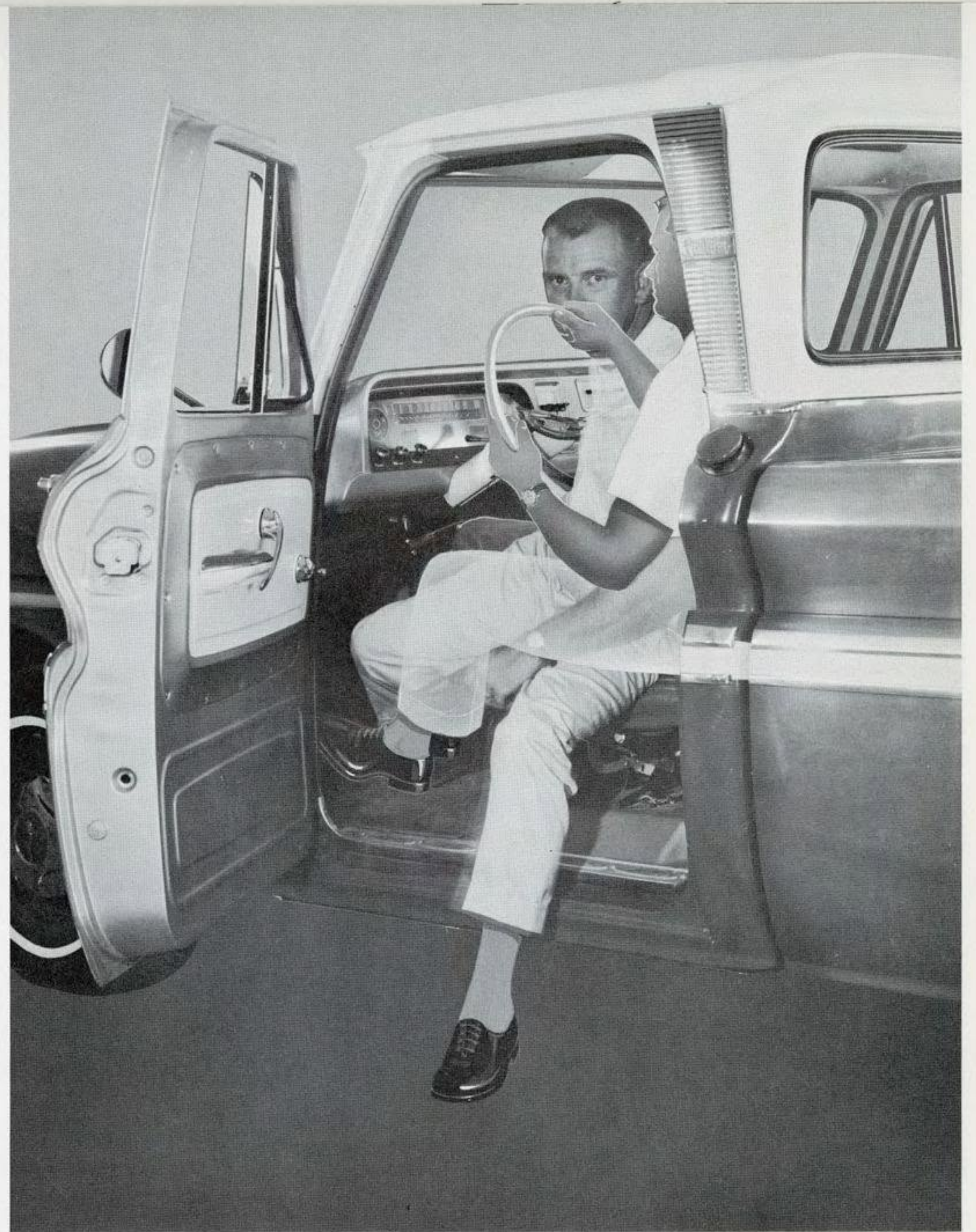

NEW ROTARY GEAR DOOR LOCKS

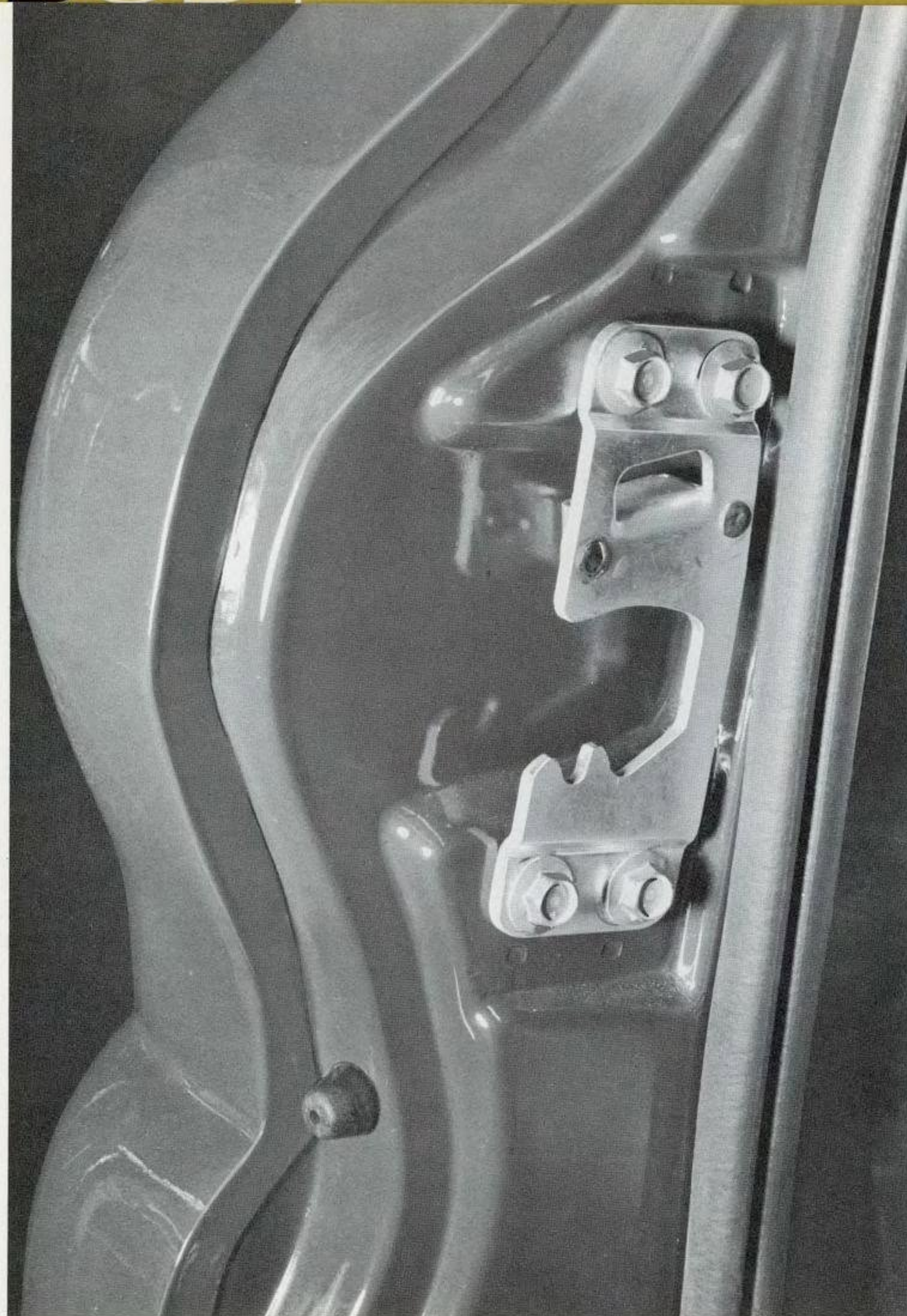

Improved locking ability for greater safety along with faster lock action for decreased door closing effort are features of the new cam-type locks which replace the former rotary-gear type on the conventional line.

In the door-closed position, the lock rotor cover (above) extends beyond the striker plate (left) both at the top and bottom, doubling contact area for more positive door retention. A spring-loaded wedge at the top of the striker bears against the rotor cover to assure positive lock engagement.

As an outgrowth of the new lock striker design with its integral alignment wedge (See description on opposite page.), lock pillars for the conventional line no longer incorporate a lock alignment wedge guide. Alignment previously was achieved through the dovetailing of a rubber wedge on the door with a guide in the lock pillar.

1964

REVISED
LOCK PILLAR

1963

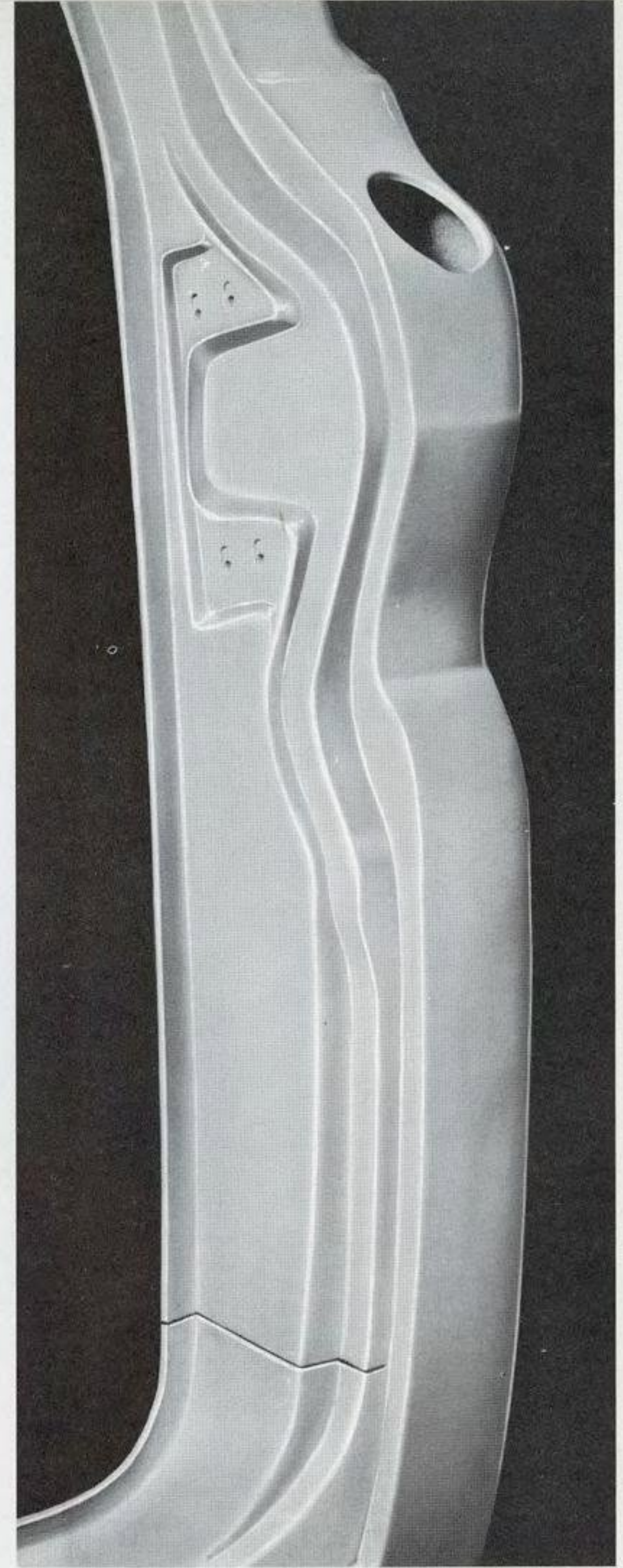

BODY

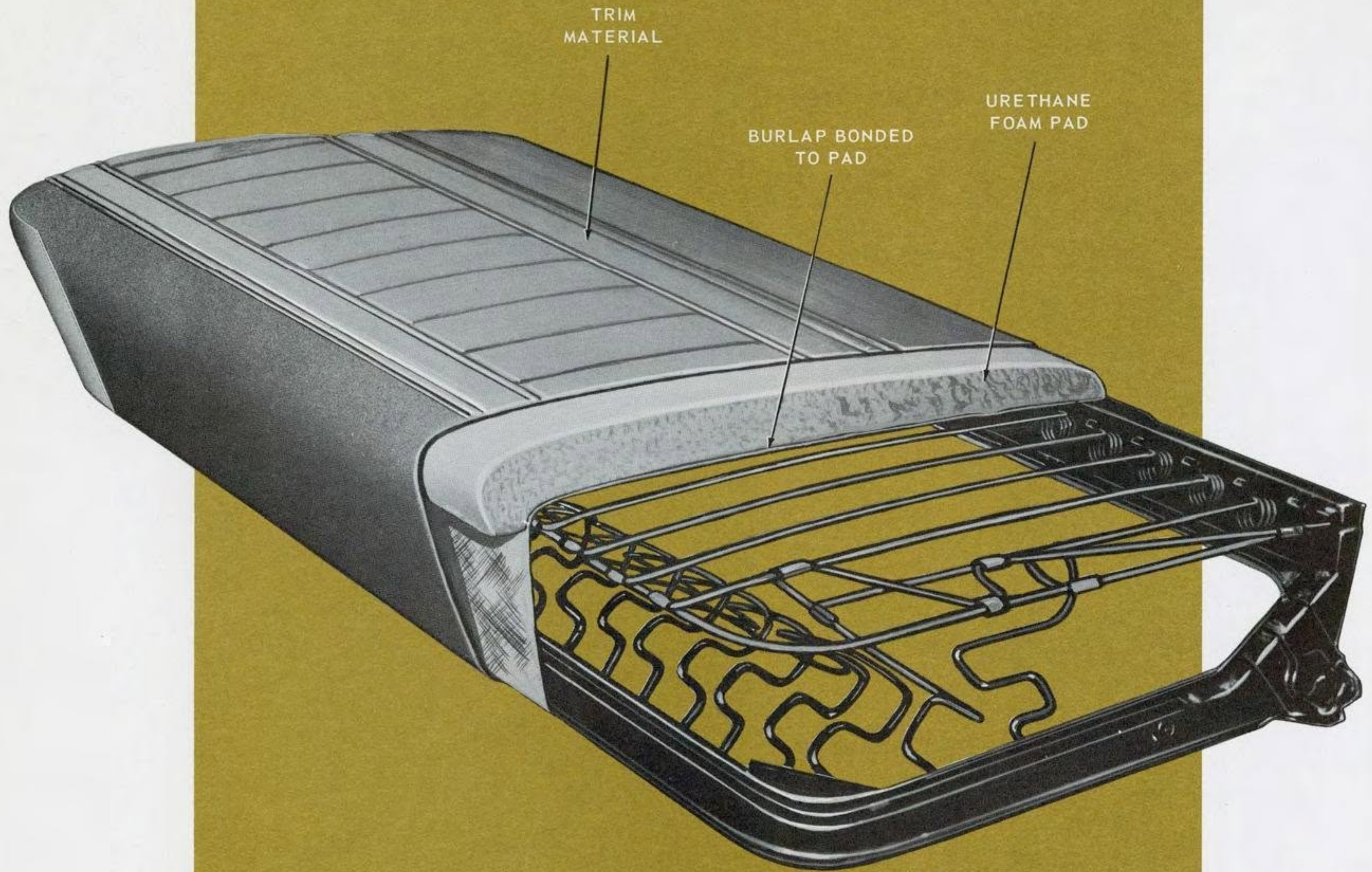

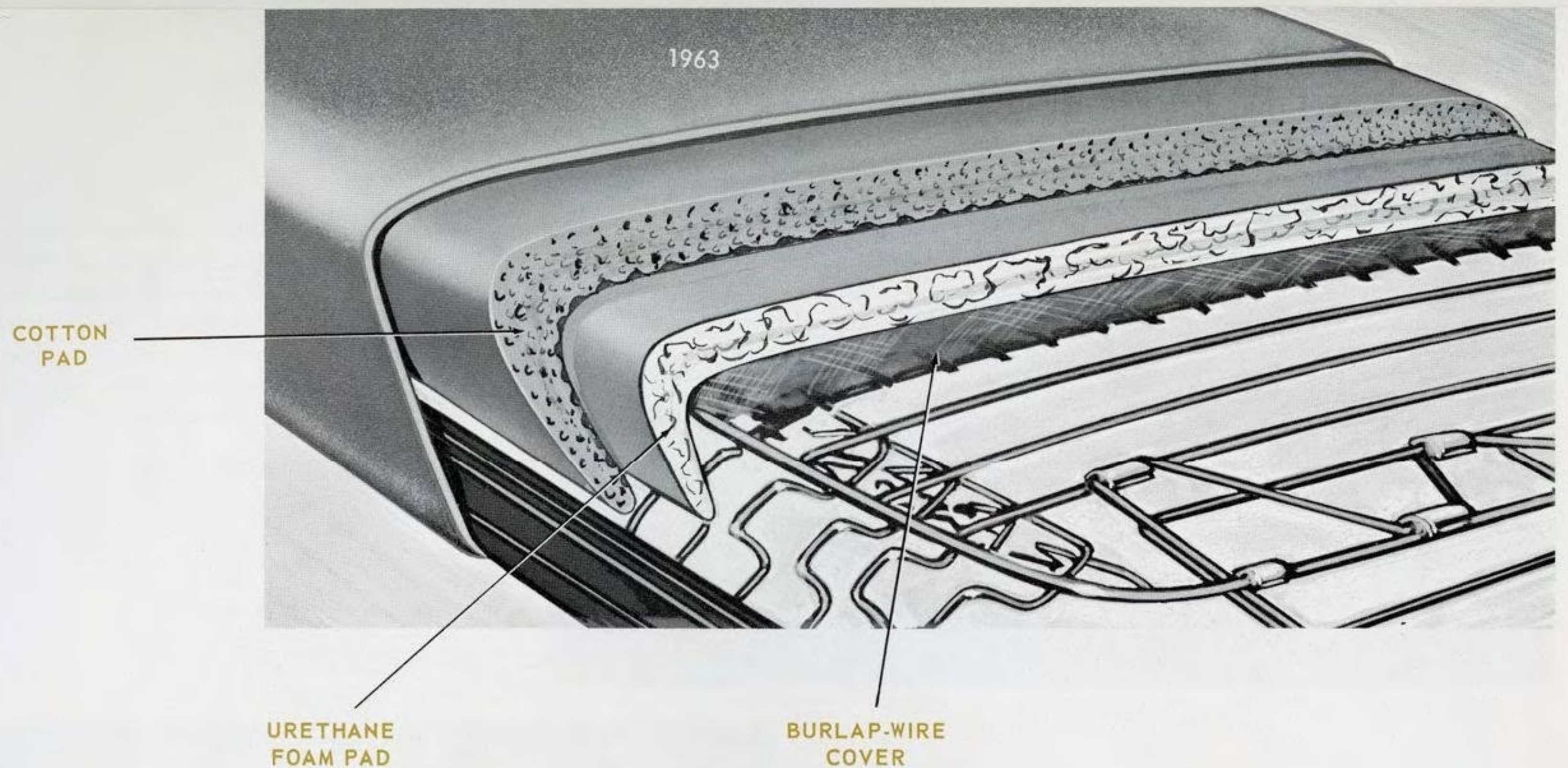

NEW SEAT CUSHION CONSTRUCTION

Seat cushion assemblies for both the conventional and Corvair 95 lines feature new, more durable construction. Both regular production and Custom seat cushions incorporate the new feature, except the full-foam seat cushion options for conventional line cabs.

In the new construction, the former multi-unit padding is replaced with a single, 1.75-inch thick pad of molded polyurethane bonded to burlap. Durability is derived in the new construction not only through the simplicity of the padding, but also through the elimination of production variance inherent in multi-unit assembly.

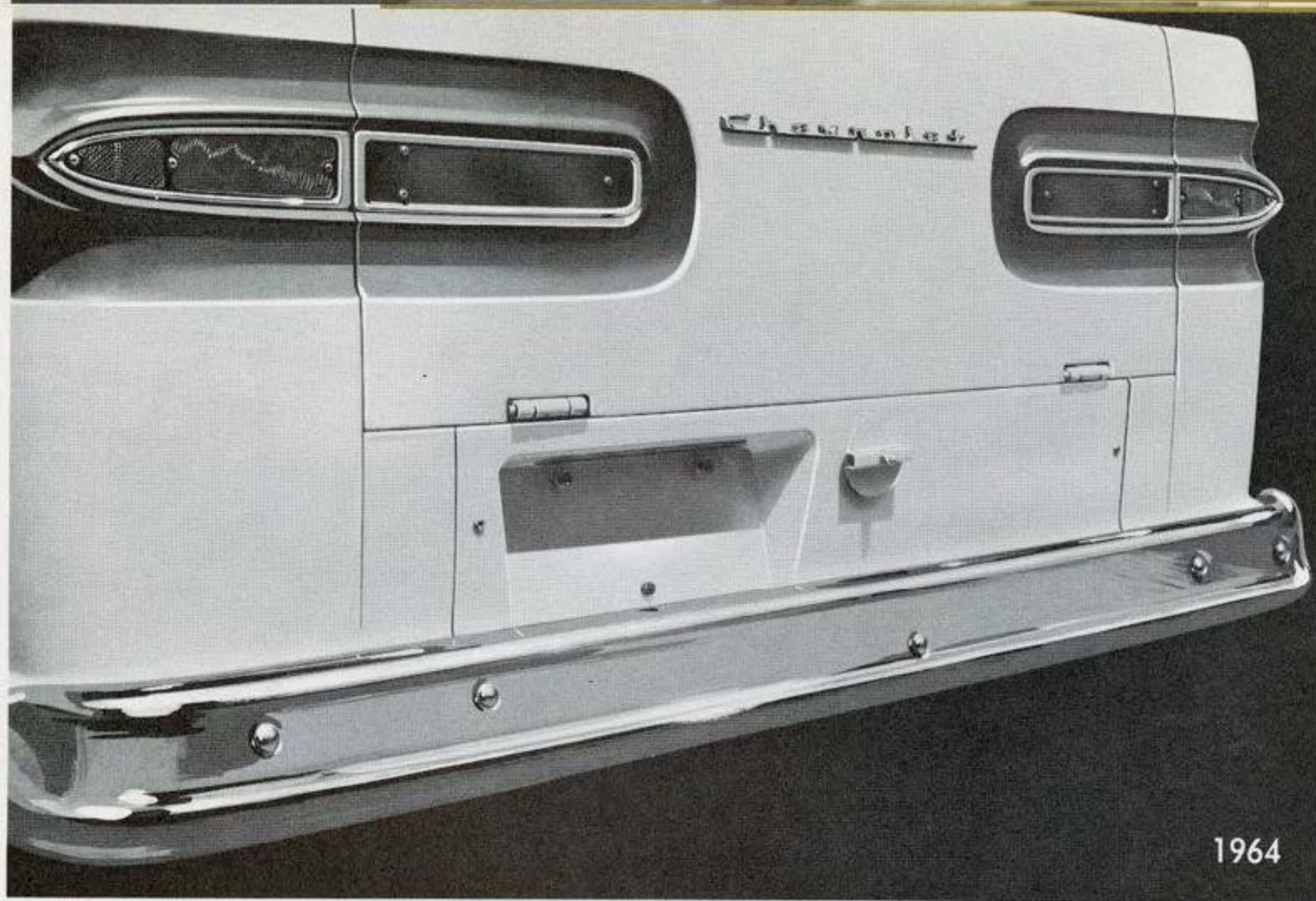

1964

Illustrated at the left is the new Corvair 95 engine access door of reinforced fiber glass designed with a license plate recess and integral overhead illumination for protection to the license plate and lamps. The door release lever also is new and is easier to operate.

The former engine access door for Corvair 95 models – illustrated at the right – utilized exterior-mounted license plate and lamps which were vulnerable to damage.



1963

CORVAIR 95 CHANGES

◆ ENGINE ACCESS DOOR

◆ AIR INLET SHUT-OFF

◆ UNDERBODY SPLASH SHIELD

Noteworthy improvements for 1964 contribute significantly to the quality concept of the basic Corvair 95 body design.

Most important of these improvements, perhaps, is the new engine access door (described on the opposite page) which affords damage protection to the license plate and its illuminating lamps.

An air inlet grille shut-off door, another new feature, ensures more effective front compartment heating by precluding the escape of cold air from the plenum chamber under air pressure build-up. Attached to the body front panel directly behind the air inlet grille, the self-hinging door of polypropylene plastic is actuated by a spring-loaded lever under the instrument panel.

Continuing the program of increased underbody weather protection introduced in mid-season 1962 with the release of a shielded manual transmission linkage system, additional protection is afforded with new front underbody sheet metal shielding for the clutch, brake, and accelerator linkage systems.

BODY EQUIPMENT

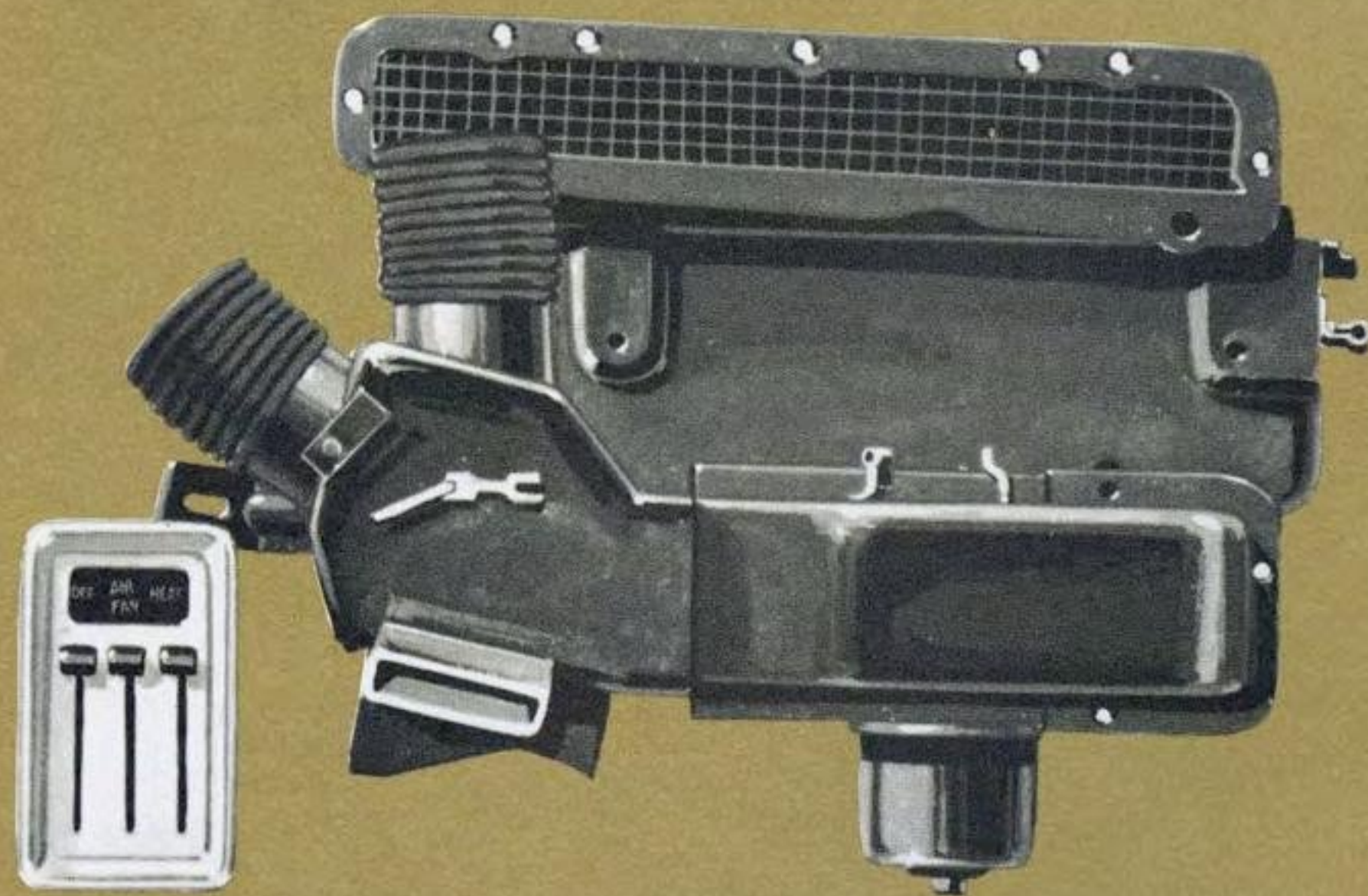

DELUXE HEATER AND DEFROSTER

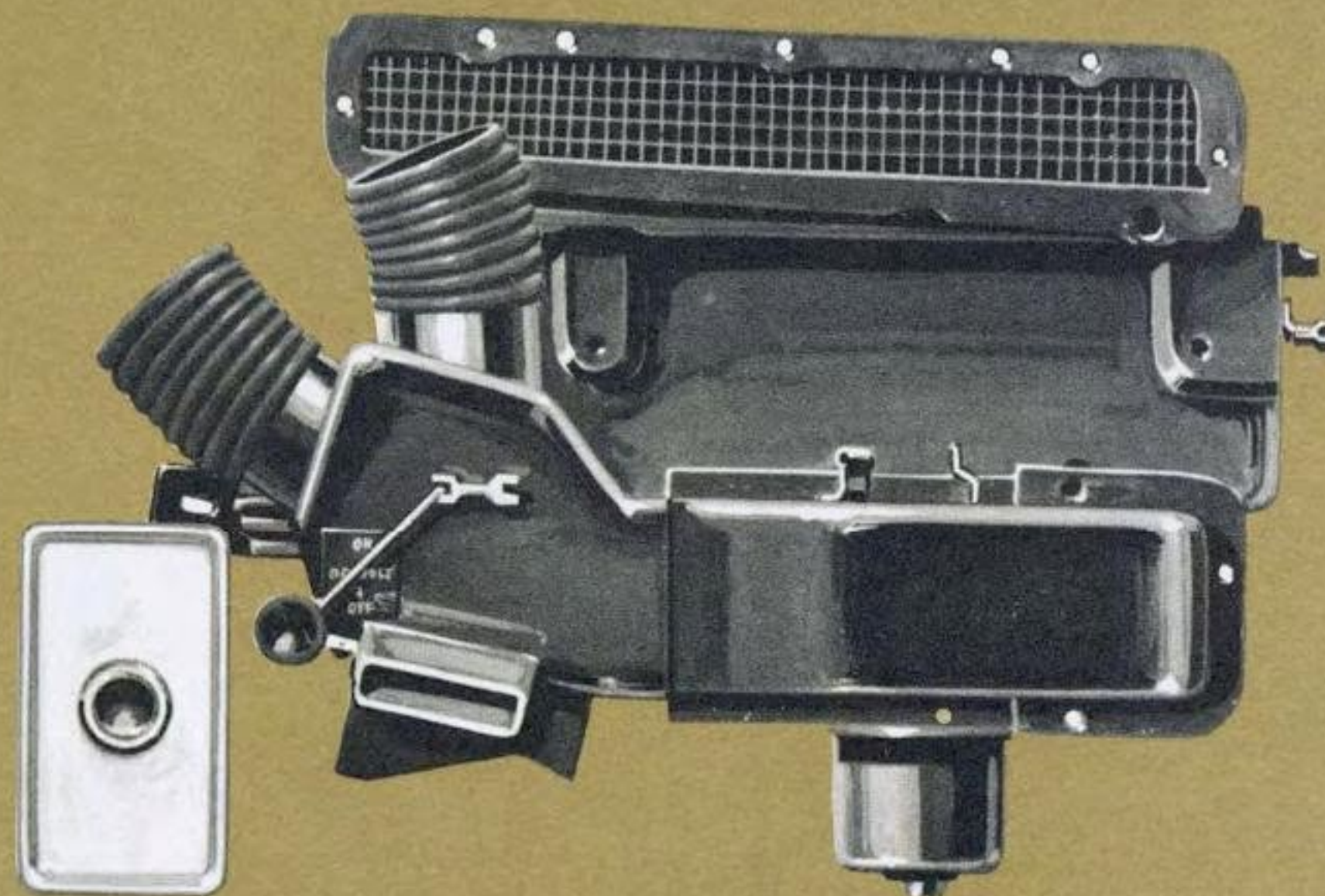

THRIFT-AIR HEATER AND DEFROSTER

NEW ACCESSORY HEATERS

DELUXE HEATER AND DEFROSTER. Rapid temperature control, more effective windshield defogging and defrosting, and easier-operating controls are features of the new Deluxe accessory hot water heater and defroster for 1964 conventional line trucks.

The new heater employs mixed air to control outlet air temperature. In this design, heater core temperature is constant, and the temperature of the outlet air is dependent upon the amount of outside air which is permitted to pass through or around the heater core. Rapid control of outlet air temperature thus is assured since core temperature and, subsequently, outlet air temperature is not limited by a thermostatic water valve as in the previous design. Though completely new, the heater and

blower assembly and distributor assembly are similar in appearance to the replaced components and are located in the same positions.

Controls for the new heater are simplified, making them easier to operate. Simplification is achieved by combining the FAN and AIR controls, thereby employing only three controls levers (DEF, AIR-FAN, HEAT) rather than four. An attendant benefit derived from combining the FAN and AIR controls is that the air duct is automatically opened as the lever is depressed downwards to activate the 3-position fan switch, eliminating the possibility of not having air to heat. Control operation also is abetted through a 2-to-1 lever ratio, replacing the former 1-to-1



Jet-type defroster outlets at either side of the radio speaker grille in the instrument panel crown direct air more efficiently to the windshield than the former slot-type outlets, improving defrost time and pattern.

ratio. In addition, control identification is more positive through the use of an illuminated window carrying the control designations. Control levers are illuminated by window light passing through slots in the bottom of the bezel surrounding the window. Formerly, general illumination and marked levers were employed.

Windshield defrosting and defogging with the new-design heater is vastly improved through two jet-type defroster outlets in the instrument panel crown which direct air to the windshield with more force than the former slot-type outlets, in addition to directing the air at eye level for a more efficient defrost pattern.

Included with factory installations of the Deluxe heater and defroster is a paperboard insulator for the fuel tank which prevents cooling of the heated air through contact with the large expanse of the metal fuel tank, thus assuring full heater effectiveness.

The new accessory unit is available for all conventional line trucks except flat-face cowls, tilt-cabs, Step-Vans, and Series D60 models. Deluxe heaters for tilt-cabs and Step-Vans are carried forward from 1963; no heater is offered for flat-face cowls; Series D60 models utilize the 1963 Deluxe heater and blower assembly in combination with the 1964 Deluxe heater distributor assembly and the new design controls.

THRIFT-AIR HEATER AND DEFROSTER. Replacing the accessory recirculating heater and defroster is a new accessory unit designated the Thrift-Air heater and defroster which is available for all 1964 conventional line trucks except flat-face cowls, tilt-cabs, Step-Vans, and Series D60 models. The new unit, similar in design to the 1964 Deluxe hot water unit, utilizes outside air for heating rather than recirculated inside air, providing fresh air for a higher level of interior comfort along with more efficient windshield defrosting and defogging.

All components of the Thrift-Air heater and defroster are basically the same as those of the Deluxe unit except controls. Both the blower motor and air duct valve are operated with a single control mounted on the instrument panel to the right of the instrument cluster. The control bezel is labelled AIR PULL (at the top) and FAN (at the bottom). Pulling the control knob within the limits of its travel positions the air duct valve in the distributor assembly, while turning the control knob clockwise selects either of three blower motor speeds - Low, Medium, or High. Temperature control is accomplished by regulating the fan speed and positioning the air duct valve. The defroster valve is operated with a lever located directly on the heater distributor assembly.

BODY EQUIPMENT

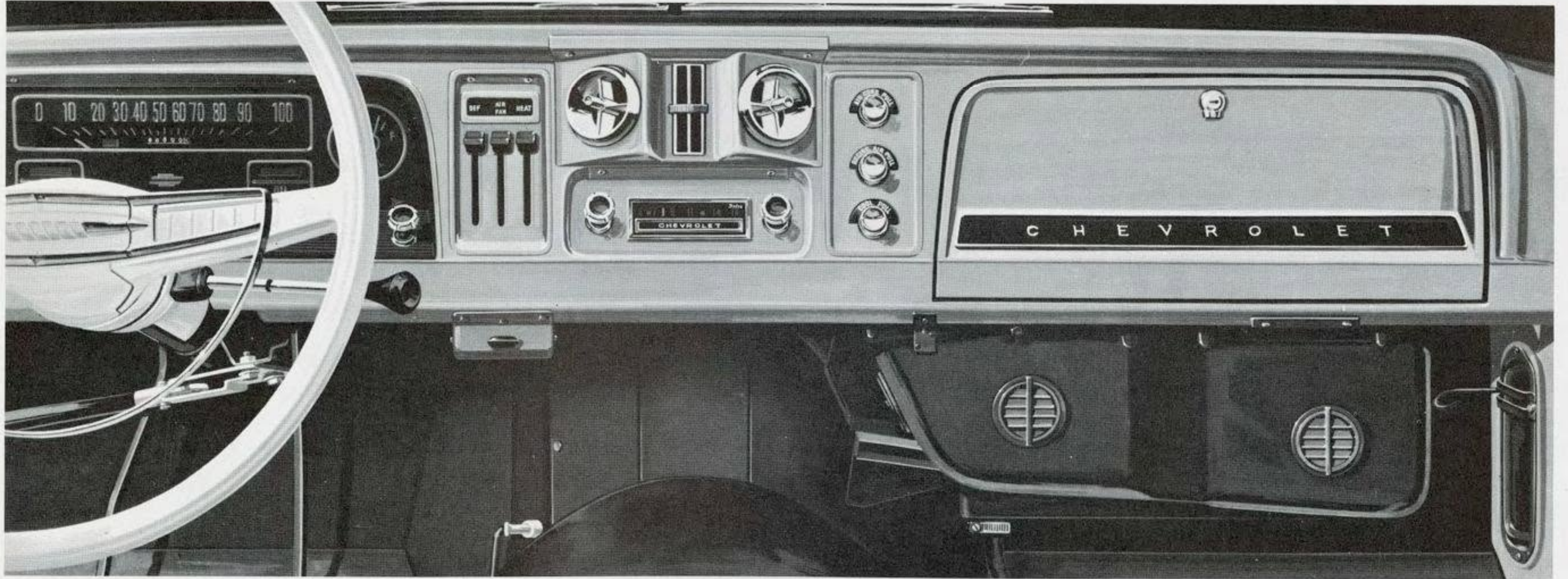

NEW ACCESSORY AIR CONDITIONING

A new air conditioning system, which replaces the former Cool-Pak unit, is released for 1964 conventional line trucks. Featuring improved cool air distribution, uniform installation for all model types, and extended model applicability, the new unit is designated the Custom Air Conditioner. The system, used in conjunction with a heater and defroster assembly, operates on full outside air, recirculated inside air, or a mixture of both. Performance of the new system is comparable to the former Cool-Pak unit with a moisture removal rate of up to 1-1/4 gallons per hour and a cooling capacity equal to 2800 pounds of ice per day. Additionally, air is recirculated more than once per minute, and air quality is high when outside air is utilized.

The new air conditioning system is available for all conventional line body types except tilt-cabs, flat face cowls, and Step-Van's. Previously, air conditioning was not released for conventional cab diesel models.

One of the most important advantages of the new air conditioning system is the improved cool air distribution achieved with three unitized outlets located centrally on the instrument panel front face in addition to three circular outlets on the evaporator case. The instrument panel outlet assembly consists of two adjustable ball-type outlets on either side of a central adjustable barrel-type outlet, permitting a high degree of flexibility in directing the flow of cool air at the instrument panel level. The assembly is mounted at the normal location of the regular production ash tray; another ash tray is provided in the air conditioning package for attachment to the instrument panel lower lip. The circular outlets on the evaporator case are equipped with directional vanes and may be rotated 360 degrees for additional cooling at any point from floor to face level.

Evaporator cases are compactly installed under the instrument panel on the right hand side, affording the advantage of only one installation for all transmission types with the attendant benefit of adequate foot room for all passengers.

Controls for the air conditioning system are identical for installations with the Deluxe and Thrift-Air heaters, except that, in the case of the latter, a TEMPERATURE PULL knob is added

to the heater control panel to operate an air shut-off door in the blower assembly which is not provided with the heater package. This knob is operated only when heating. Basic air conditioning controls, in addition to heater controls which also are utilized, consist of three pull-type knobs on the panel opposite the heater controls. The pull-type knobs are labelled: AIR COND PULL, RECIRC AIR PULL, and COOL PULL. These controls permit the system to be adapted to a wide range of atmospheric conditions.

As an illustration of maximum performance of the air conditioning system with a Deluxe heater, the following operational procedure is instituted:

1. The AIR-FAN lever on the heater control panel is depressed to the end of its travel, activating the heater blower switch to the HIGH position and opening the air shut-off door in the blower.
2. The AIR COND PULL knob is pulled to the full-out position, opening fully the air diverter valve in the evaporator case to direct air flow to the air conditioning outlets.
3. The RECIRC AIR PULL knob is pulled to the full-out position, positioning a door in the heater assembly to close off outside air.
4. The COOL PULL knob is pulled to the full-out position, setting a Ranco valve control lever at its coldest position, and simultaneously activating the compressor electrical circuit.

Except for the AIR COND PULL knob, the settings of each of the above controls can be varied to temper outlet air to suit individual requirements. Maximum quietness also is achieved by pushing-in the RECIRC AIR PULL knob, permitting the system to run on outside air.

Control operation is identical for installations with the Thrift-Air heater, except that the introduction of outside air and the selection of blower speed are accomplished, respectively, by pulling the AIR PULL knob and turning the FAN switch on the heater control panel.

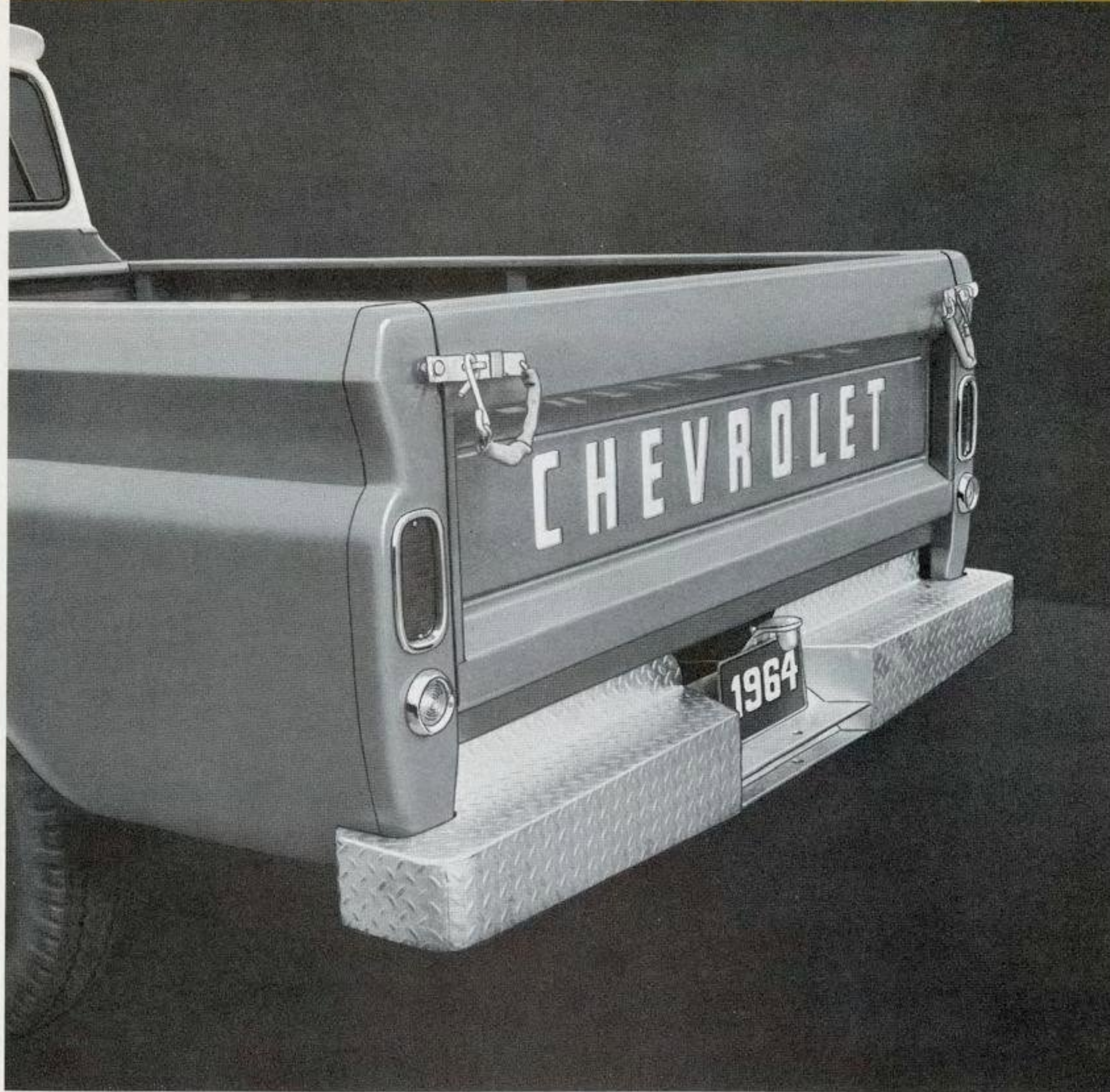

New rear step-bumpers with trailer hitch provisions are offered as new options and accessories for 1964 CK10, 20 Fleetside and Stepside pickups. Illustrated is the unit for Fleetside pickups; the Stepside pickup unit is essentially the same. Both are painted Silver.

The sturdy step-bumper, which ties into the frame side rails, affords ease of loading and unloading over the closed tailgate. Raised embossments assure a good foothold. Two holes in the reinforced central section permit attachment of standard trailer hitches.

NEW REAR STEP-BUMPER

RPO B98 - SIDE TRIM MOLDING
EQUIPMENT (Fleetside Pickups)

Bright body and pickup box moldings
Off-White paint treatment between upper
and lower moldings when body color is
not Off-White or White

RPO V37 - CHROME BUMPER
EQUIPMENT (CKR10 - 30 SERIES)

Chrome front and rear bumpers wherever
applicable
Chrome hub caps, except for K models and
R models with accessory wheel trim disks

RPO Z60 - CUSTOM EQUIPMENT
(R10 SERIES)

Bright windshield reveal moldings
Rear door or tailgate ornamental inserts
Cigar lighter
Left hand armrest
Anodized aluminum trim plate for dispatch
box door (*)
Nylon-faced pattern cloth and vinyl seat
trim (*)
Right hand sunshade
Two-tone steering wheel
Two-tone front door inner panels
Engine air outlet grille
Foam padding for seat backrest

RPO Z61 - CUSTOM APPEARANCE
EQUIPMENT (CK10-30 SERIES)

Silver anodized aluminum radiator grille
assembly (*)
Bright windshield reveal moldings
Bright cab upper rear quarter trim plates (*)
Bright single-unit body side moldings,
except Model C3605
Steering wheel with chrome horn ring
Bright trim for instrument panel control
knobs (*)
Two-tone front door inner panels (*) and
Suburban sidewalls
"Chevrolet" trim plate for dispatch box
door (*)

RPO Z62 - CUSTOM COMFORT
AND CONVENIENCE EQUIPMENT
(CKLM10 - 80 SERIES)

Left hand armrest
Right hand sunshade
Right hand front door key lock
Cigar lighter
Undercoating on front compartment area
Woven cotton fiber pad for underside of
cowl (*)
Nylon-faced pattern cloth and vinyl seat
trim, except panels and M80 models
with auxiliary transmissions (*)
Full-foam seat cushion and foam padding
for backrest, except single-unit bodies
and M80 models with auxiliary trans-
missions
Foam padding for seat backrest - Suburbans

(*) - New or revised.

- ◆ NEW 164 CU. IN. 6-CYLINDER ENGINE -
CORVAIR 95 LINE
- ◆ NEW AND EXTENDED TRANSMISSION
AVAILABILITY
- ◆ NEW 34,000-POUND BOGIE OPTION -
MW80 TANDEMS
- ◆ NEW 23,000-POUND AXLE OPTIONS -
CELTU80
- ◆ OTHER IMPORTANT POWER TRAIN
REFINEMENTS

power train

POWER TRAIN

The various components which comprise the power train line-up for both the conventional and Corvair 95 lines feature numerous improvements and refinements to promote greater durability, serviceability, and performance. Among the modifications to the conventional line engines are new manifold heat valves, sealed starter motors, and improved exhaust systems. The displacement of the Corvair 95 engine is enlarged to 164 cubic inches for a substantial improvement in performance characteristics. Both the manual and automatic transmissions have undergone refinements, and new designs and revisions highlight the expanded rear axle line-up for 1964.

CORVAIR 95 ENGINE. A substantial displacement increase to 164 from 145 cubic inches is achieved by lengthening the piston stroke from 2.60 to 2.94 inches. The base engine with an 8.25-to-1 compression ratio produces 95 horsepower at 3600 RPM and 154 pound-feet of torque at 2400 RPM in comparison to 80 horsepower and 128 pound-feet of torque for its 1963 counterpart. An optional high performance version of the 1964 design features a 9.25-to-1 compression ratio, 110 gross horsepower at 4400 RPM, and a gross torque output of 160 pound-feet at 2800 RPM. The increased performance is the result of a higher lift camshaft, recalibrated carburetors, and the higher compression ratio. Fuel requirements remain the same for the base engine (regular gas) while the high performance engine necessitates the use of premium fuel.

Overall engine durability is extended with larger component size and improved material content. Crankshaft material is changed from carbon to alloy steel, while premium aluminum replaces copper-lead alloy for main and connecting rod bearings. Silichrome steel inlet valves, specially heat-treated, minimize corrosion and valve burning. Connecting rod I-sections are increased in size for greater column strength to accept the larger piston loads. Reduced piston compression height and narrower piston rings compensate for the increased crank throw. Combustion chambers are designed to maintain efficiency and approximately the same compression ratio.

Carburetor recalibration with increased throttle bore sizes and larger venturi openings provide satisfactory fuel delivery without necessitating manifold changes. The continued use of stellite-faced exhaust valves, improved exhaust valve rotators, and cast-iron, chrome-plated compression rings complement the larger and stronger 1964 engine components as outlined above.

Die-cast magnesium replaces fabricated steel as blower assembly material for higher blower burst strength and reduced weight. The latter feature provides the secondary advantage of extending belt and bearing life. Cooling vanes are reduced in number from 16 to 11 but, through an increase in vane pitch, the volume of cooling air supplied is not affected. A higher cooling capacity 12-plate oil cooler design replaces the 5-plate unit previously used. Oil-wetted paper air cleaner elements replace permanent polyurethane type units for easier servicing, better filtration, and greater dirt capacity.

Higher electrical loads can be handled by a new 35-ampere generator, replacing the 30-ampere unit as base equipment. In addition, generator flexing and vibration are reduced for Powerglide transmission equipped models through a new solid-type mounting. The generator is now mounted to the bracket with a retaining bolt, lockwasher, and nut, eliminating the rubber bushing and sleeve formerly used.

New accelerator linkage provides a more positive return to idle and improved pedal "feel." The pull-back spring mounting location is changed so that the spring is attached to a tab at the upper engine shield rather than at the left hand air cleaner support. In addition, a new plastic housing for the pedal rod pivot produces smoother pedal operation. The accelerator pedal also is new, being of polypropylene plastic for lighter weight and better wear characteristics.

A new "bent-finger" type clutch, wherein the pressure applied to the driven disk is somewhat in proportion to the speed, results in greater capacity and increased durability. Integral clutch fingers project from the inside diameter of the conical-shaped Belleville washer design at a substantial angle to the plane of the clutch assembly. As the assembly revolves, centrifugal force tends to increase this angle by pulling the fingers away from the hub, thereby applying greater pressure to the pressure plate. Clutch capacity is increased with no increase in pedal effort and boosters or heavy over-center springs are not required, as in the case of a coil spring design. Clutch durability is further increased by a built-in cooling provision. Radial projections on the pressure plate act as cooling fins. As the clutch rotates, these projections help force air through cast-in cooling slots around the outer edge. Greater pressure plate strength is achieved by the use of pearlitic malleable iron which has considerably more tensile strength than the formerly used ordinary cast iron. A lighter flywheel with a stepped-face is provided to accommodate the new clutch.

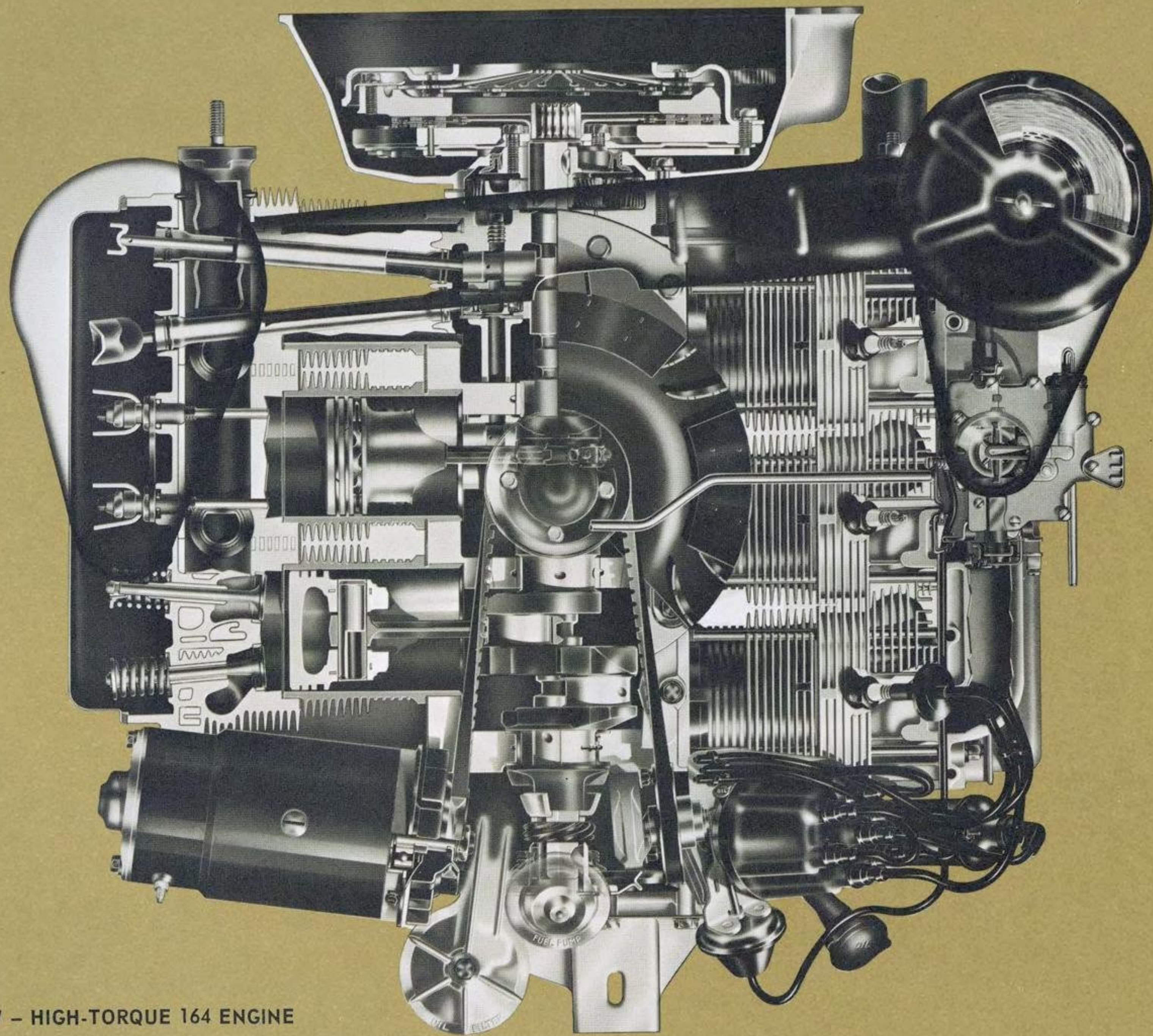

PLAN VIEW - HIGH-TORQUE 164 ENGINE

HIGH-TORQUE 164 ENGINE PERFORMANCE

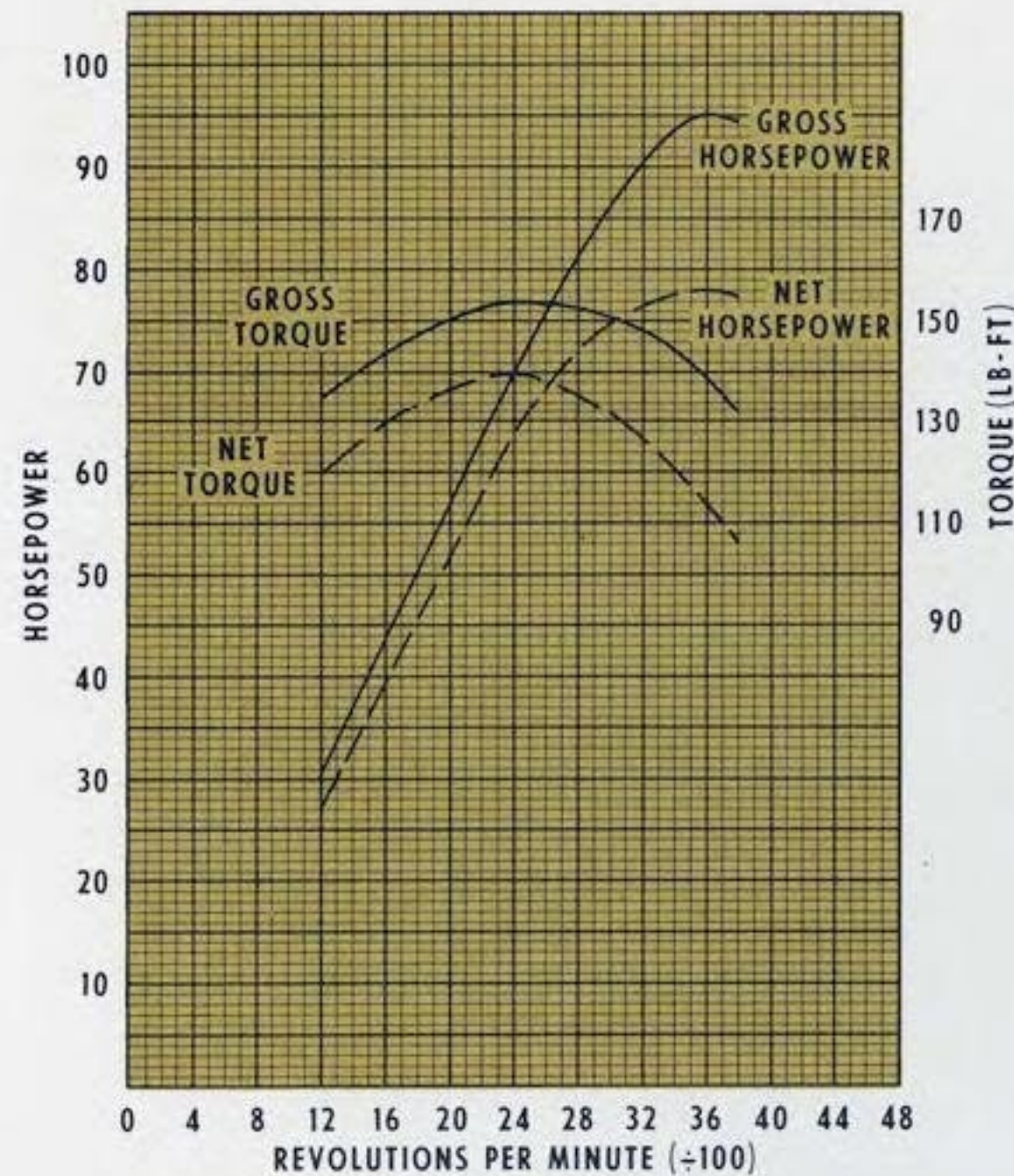

WITH REGULAR CAMSHAFT

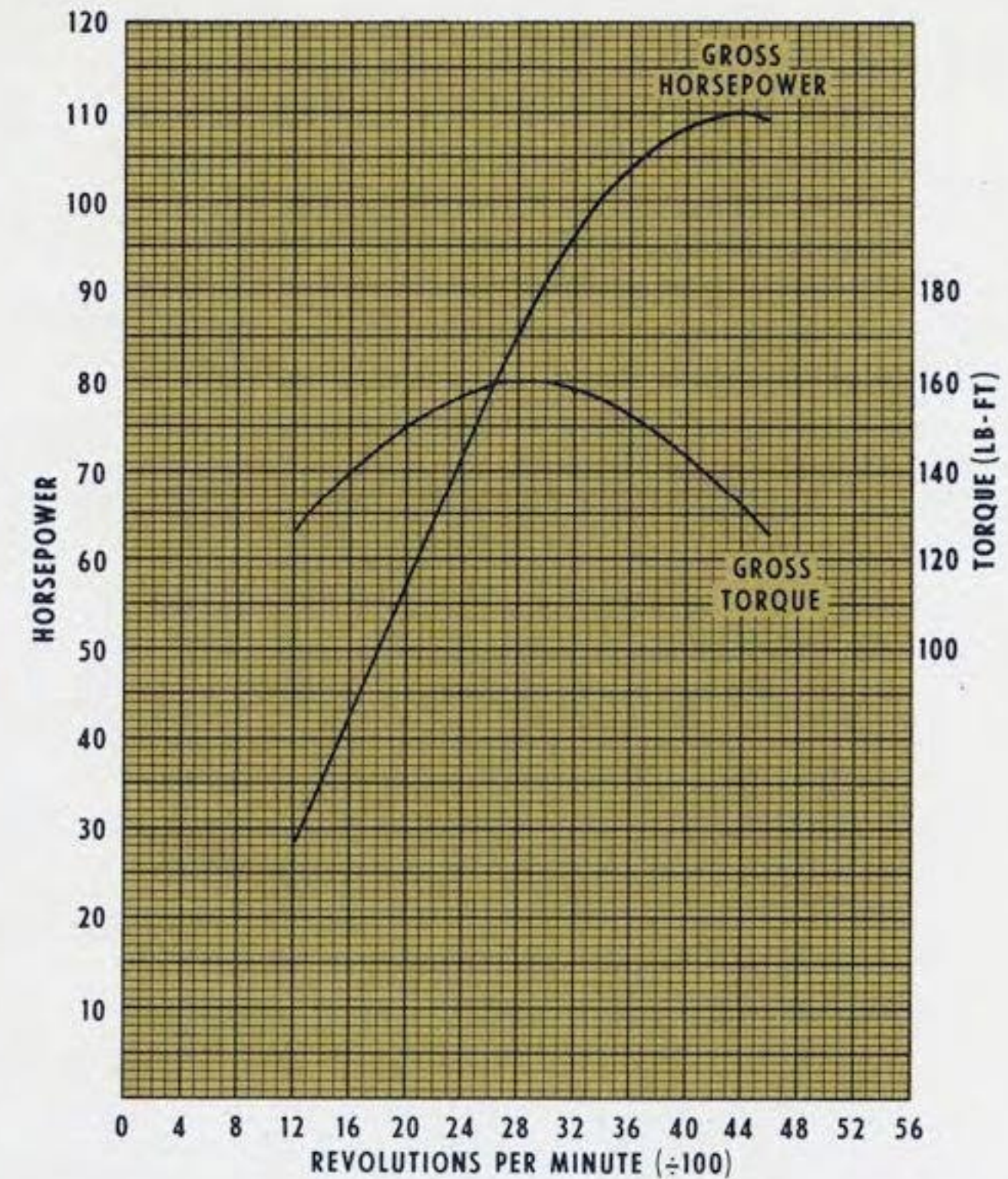

WITH SPECIAL CAMSHAFT

L-6 ENGINES. All in-line 6-cylinder engines incorporate a new stainless steel exhaust manifold heat valve, shaft, and bushing. Stainless steel, a high heat-resistant material, minimizes the possibility of exhaust manifold heat valve sticking and resultant improper engine warm-up, carburetor icing, and fuel vaporization problems. In addition, Series P20 and P30 models feature a new water-jacketed carburetor adapter, heated by water from the engine cylinder block, to minimize carburetor icing.

The 292 L-6 engine features a higher lift camshaft for improved volumetric efficiency and greater engine power. Also, changed ramp and lobe contours improve cam durability, produce higher engine speeds, and reduce valve "bounce" and noise. Optional applications of the 292 engine for Series CLS50 models

also include a larger, more durable 12-inch coil spring clutch, replacing the 11-inch diaphragm unit previously used. Heater performance is improved in all applications of the 292 power plant through the substitution of a 180-degree thermostat in place of the 170-degree thermostat employed in 1963.

V-8 ENGINES. For 1964, the Delcotron generator mounting face for the 283 and 327 V-8 engines is cast integrally with the left hand exhaust manifold. Mounting of the generator closer to the engine reduces vibrational tendencies, promoting durability.

A more effective warm-up of the 327 V-8 engine is achieved with an improved water pump external by-pass system. The thermostat housing-to-pump inlet hose diameter is increased

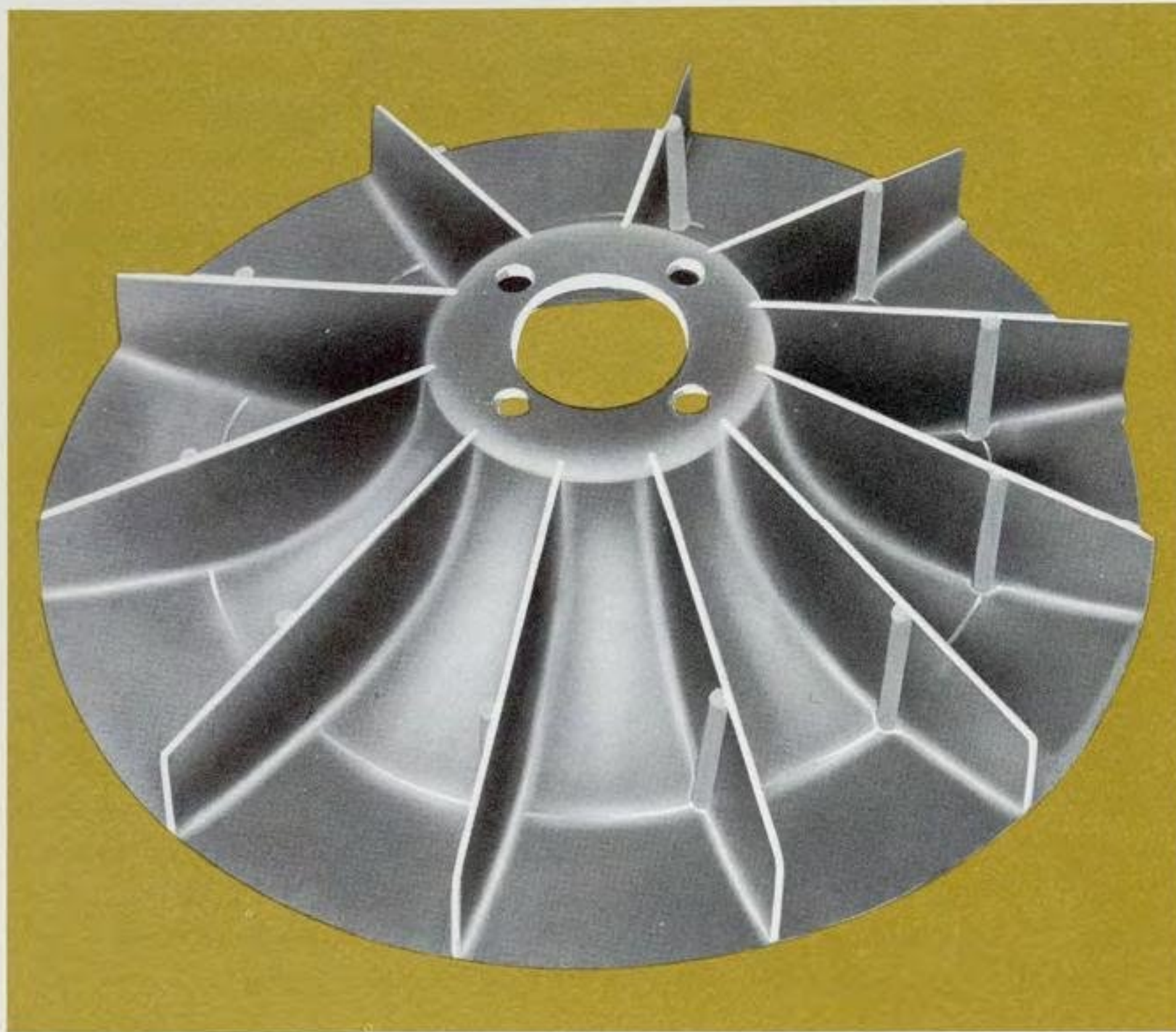

A new, lightweight die-cast magnesium blower replaces the fabricated steel-type blower on Corvair 95 engines. Increased blower burst strength, plus longer blower bearing and belt life, are features of the new design.

from 3/4-inch to 1-inch allowing a more effective coolant circulation through the engine when the thermostat is closed and thereby minimizing the possibility of hot-spot formation. A new, later-opening, 180-degree thermostat is less restrictive to water flow and contributes to improved heater performance.

The 327 V-8 engine life is further improved through better oil filtration provided by a 2-quart capacity oil filter which replaces the 1-quart filter previously used. The 2-quart unit was formerly available as a Regular Production Option.

The High-Torque 348 (4-barrel carburetor) and High-Torque 409 engines plus the diesel power plants are unchanged for 1964. Availability of the High-Torque 348 Special (2-barrel carburetor) is extended, however, to include all Series 60 models except D60.

OTHER ENGINE FEATURES. Exhaust system improvements are incorporated throughout the model line-up. Corvair 95 vehicles utilize a new, larger, oval-shaped muffler with aluminized heads to improve sound deadening and resistance to corrosion. Exhaust pipes are increased in thickness from 14 to 12-gauge for conventional line Series 10-30 vehicles. Mufflers used on Series 50-80 models now incorporate aluminized steel passage tubes and expansion chamber baffles.

All 1964 Chevrolet trucks feature revised fuel tank filler tubes and caps which conform to new SAE standards. Both the locking tangs of the cap and the openings on the filler tube cap retainer are designed to eliminate the possibility of non-vented caps being used in place of the standard vented cap.

Improved fuel filtering is achieved on all 230, 283, and 292 cubic inch engine applications through an optional frame-mounted, in-line fuel filter. The paper element filter augments the standard sintered bronze filter in the carburetor fuel inlet line and the wire mesh fuel tank filter.

Air cleaner efficiency is increased for 230, 283, and 292 cubic inch engine installations in Series CLMST 50-60 models through a new oil-wetted paper element replacing the polyurethane type element previously used. Advantages of the new disposable-type element include better filtration, easier servicing, and greater capacity. In addition, the one-quart oil bath air cleaner option again will be offered for 1964.

All Series 50 and 60 cellular-type radiator applications are replaced by new units of tube-and-center construction for increased durability.

New sealed starter motor drive assemblies for all gasoline engine applications prevent contamination of the over-running clutch by road dust, engine oil, or moisture. In addition, a new heavy-duty starting motor is available optionally for all Step-Van models. The new heavy-duty unit incorporates such features as improved brush life; tangent wick oilers; 24-volt solenoid contact discs; sealed clutches; and a solenoid boot at the mounting flange.

The 52-ampere Delcotron generator, RPO K82, is cancelled and replaced by a new 55-ampere unit, RPO K77. The new generator provides additional capacity for severe usage where high current demands exist at engine idle conditions.

The radiator shutter equipment option is revised for Series CM80 model applications. These models now must be equipped with either air-hydraulic or full-air brake systems before the shutters may be ordered.

TRANSMISSIONS. 1964 transmission improvements include extended availability plus design refinements to both manual and automatic units.

Extension length is reduced approximately three inches for both the 3-speed and Powerglide transmissions. This reduction, applicable to C1405-06-16, C15, and C25 models, results in improved extension bushing durability.

Availability of both the standard ratio and close-ratio Spicer 3000 Series transmissions is extended to include Series CLS60 models equipped with optional 8-cylinder engines. Greater customer selectivity as to ratio and design results from the expanded line-up which previously consisted of only the Clark

version of standard 5-speed and close-ratio 5-speed units.

A new Spicer Series 7041 4-speed auxiliary transmission is released for optional use on the new W80 models. Although similar in design to the Spicer Series 6041 available for M80 models, the new transmission differs as to ratios and durability. Increased-size components throughout the gearcase provide the greater capacity to accommodate the higher operating torques of the 6V-53 diesel engine. Ratios of the new unit are: First, 2.31; Second, 1.21; Third (direct), 1.00; and Fourth (overdrive), 0.83.

The Powermatic automatic transmission incorporates refinements for improved performance and greater durability. A longer TV valve stroke reduces sensitivity to adjustment. This feature, coupled with new transmission linkage, results in easier maintenance and improved shift point accuracy. Teflon material, used for all piston seals, improves sealing quality. Higher grade steel is used for all pinion gears and the sun gear is redesigned for more even contact under load. Sintered bronze clutchplates, fully interchangeable through the various ranges, are more durable and less susceptible to seizure.

Durability and quietness of operation are increased for both 3-speed and 4-speed Corvair 95 transmissions through several design refinements. Both transmissions have an 0.060 inch larger input shaft diameter for increased torque capacity.

Reverse gear ratio for the 3-speed transmission is changed from 3.96 to 3.50. The other ratios (1st, 3.50; 2nd, 1.99; and 3rd, 1.00) remain unchanged. Noise level is reduced through the use of new gears which have greater pitch angles and higher helix angles.

Improved synchronization is achieved in the Corvair 95 4-speed transmission by replacing the radial needle bearing between the 2nd and 3rd speed gears with a shoulder in the mainshaft at this location. The shoulder takes the thrust from the second speed gear, giving an improved shift feel. An increase in the number of reverse idler gear teeth from 14 to 17 contributes to quieter operation. Transmission shifting reliability is improved by eliminating the roll pins formerly pressed into the 1-2 and 3-4 shift fork shaft assemblies. The pins are now an integral part of the shaft and thus cannot work themselves loose and out of position.

DRIVELINE. Driveline configuration is revised for C1405-06-16, C15, and C25 models equipped with 3-speed or Powerglide transmissions. A 2-piece propeller shaft design replaces the one-piece version used previously. Vehicles equipped with the 4-speed

transmission already have 2-piece drivelines. Advantages of this design include reduced driveline noise and vibration, a shorter transmission extension, and service-free universal joints. These permanently-sealed units, also used for 1964 Corvair 95 models, are similar in design to those used on passenger cars, and require no periodic service under normal operating conditions. A tapered projection of the new bearing housing fits into the rubber U-shape of the spring-loaded, steel-backed seal which is press-fitted on the trunnion shoulder. Skewing is minimized through the use of a nylon ring between the roller bearings and the base of the trunnion boss.

REAR AXLES. The brake flange plate attachment to the axle housing tube is improved in durability for Series 10 Salisbury-type rear axles. Formerly, the outer axle housing tube ends were joined to the brake flange plate through the use of rolled serrations. In the new design, a rectangular steel rim is welded to the outer tube ends. The rim is then piloted and bolted to the brake flange plate.

Series 10 rear axles are further improved with new differential side gears which are machined by an improved process (Reva-Cycle) and are of new nickel-alloy steel material. Utilization of the new machining process offers the advantage of greater accuracy and therefore better quality control, and allows the usage of increased tooth sections. Addition of thrust washers behind the side gears eliminates the possibility of the side gears wearing into the differential case.

A new ratio of 4.57-to-1 replaces the previously used 5.14 ratio as base equipment for Series P20 Step-Van models. Other axle details, including capacity, are unchanged with the only available option, the "NoSPIN" differential, also utilizing the new ratio. Availability of the optional 5.83-to-1 ratio for Series P30 trucks is cancelled for 1964.

Series 20, 30, and 50 truck rear axles incorporate a new front pinion bearing design. Revised thrust angles of 35 degrees forward and 20 degrees rearward are convergent on the inner race and reduce the effect of misalignment at the straddle end, thus eliminating spalling and extending bearing life.

Synthetic rubber replaces leather as the pinion oil seal material for all Chevrolet-built 15,000 pound and 17,000 pound rear axles. Synthetic rubber, as compared to leather, is less susceptible to shrinkage and is less affected by temperature variations. Usage of the Chevrolet 17,000 pound 2-speed rear axle is restricted to

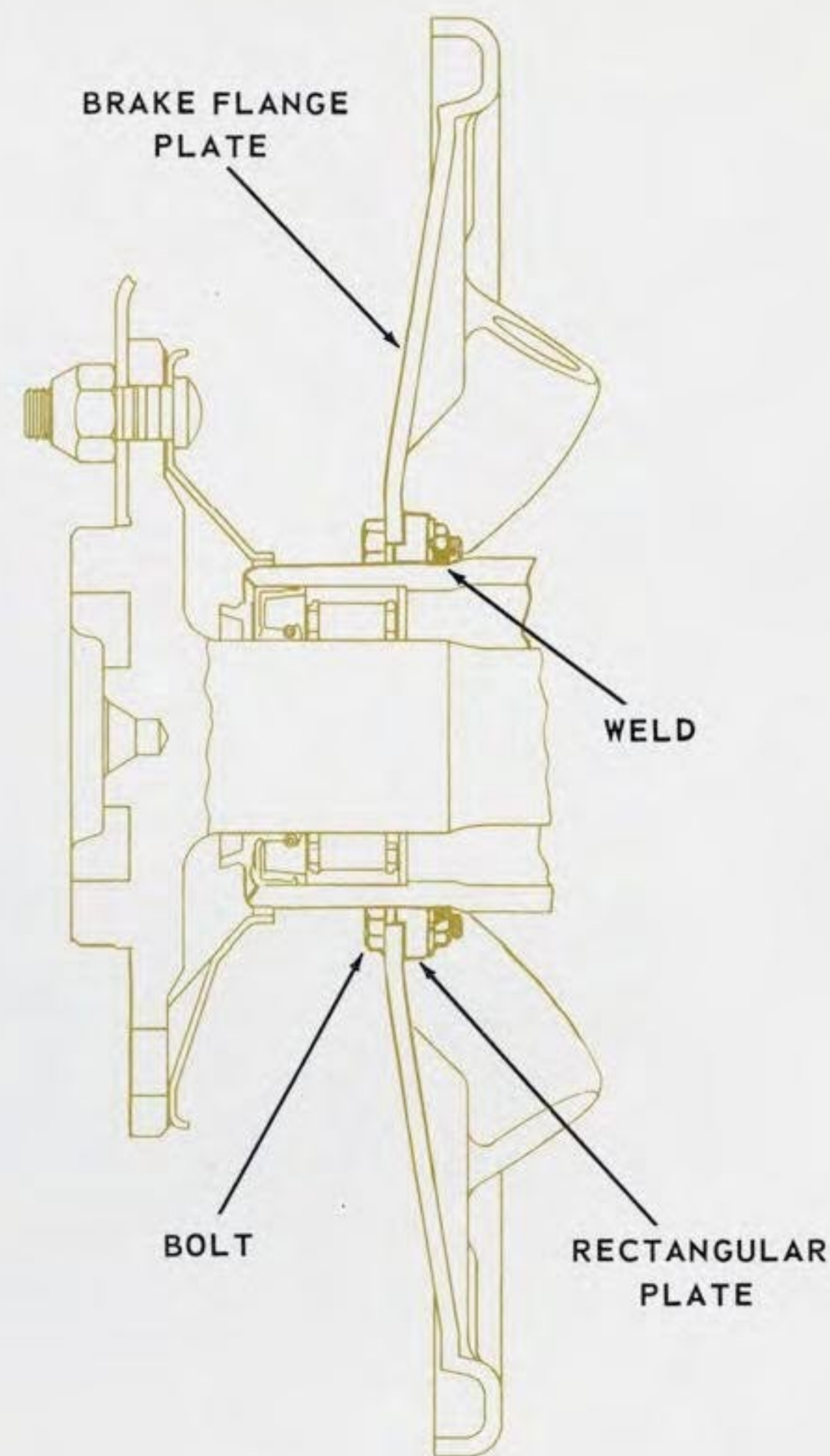

Series 10 Salisbury-type rear axle durability is improved through a new axle housing tube-brake flange plate attachment design. A rectangular steel rim, welded to each tube at the outer end, is piloted and bolted to the brake flange plate, providing a more positive attachment than that with the rolled serrations previously used.

the 292 L-6 engine for Series CLT60-60H models. The Eaton 17,000 pound 2-speed design will continue to be available, however, for use with the V-8 engines.

A new ratio of 4.87/6.65-to-1 is available optionally for EU80 models. Identical in all other respects to the base equipment 18,500 pound 2-speed rear axle, the numerically lower ratio is designed to give improved fuel economy while maintaining satisfactory performance.

Tandem rear axle availability is increased for 1964 with diesel applications and new higher capacity options. Two Eaton single-speed rear axles are combined for a bogie rating of 30,000 pounds on the new W80 models. Similar in design to those used on the M80 tandems, the axles differ only in gear ratio which is 5.57-to-1 for the W80, as compared to 7.17-to-1 for the M80.

In addition, two heavy-duty Eaton single-speed axles in combination with the RT320 Hendrickson suspension result in a new 34,000 pound bogie option for MW80 tandem models. Axle design is similar to that used in the base tandem suspensions utilizing an inter-axle differential to divide the driving power equally between the two units. Overall axle construction, however, is heavier throughout, with component size and strength being equal to that of the Eaton 18,500 pound single-speed rear axle. Axle ratios for the new tandem options are 7.17-to-1 for M80 models and 6.50-to-1 for W80 models.

Maximum available rear axle capacity for Chevrolet trucks is increased from 18,500 to 23,000 pounds for 1964. Available optionally for Series CELTU80 models in both single and air-shift 2-speed versions, the new Eaton-built axles have ratios of

6.67-to-1 (single-speed) or 6.71/9.14-to-1 (2-speed) for gasoline engine trucks and 5.43-to-1 (single-speed) or 5.43/7.39-to-1 (2-speed) for diesel-powered vehicles. Overall design of the 23,000 pound axles is similar to that of the 18,500 pound Eaton axles. Increased diameter axle shaft, drive gear, and pinion shaft; larger axle housing section and drive gear face width; plus greater capacity outer pinion, pilot, left-right hand differential, and inner-outer wheel bearings are typical of the component changes made to obtain the 23,000 pound rating.

Axle shifting between high and low range for the 23,000 pound 2-speed rear axles is accomplished by an air-torsion spring shift system. This differs from the electric type arrangement used on Eaton 18,500 pound 2-speed axles in the method of actually accomplishing the shift. In the all-electric system, an electric motor is used to wind the spring which provides the eventual force required to move the shift fork and change the axle range. An air-actuated push rod provides this force in the air-shift system. The system consists essentially of an air chamber and a torsion spring drive assembly. Movement of the selector knob electrically activates the solenoid valve which opens or closes an air passage and permits air pressure to be applied or released from the air-shift unit diaphragm which in turn winds or unwinds the shifting spring to accomplish the eventual shift.

Corvair 95 models utilize a new, numerically-lower standard rear axle ratio of 3.55-to-1, replacing the previously used 3.89-to-1 ratio and contributing to overall improved vehicle fuel economy. Vehicles equipped with the Positraction option also utilize the 3.55-to-1 ratio with no other ratios being available.

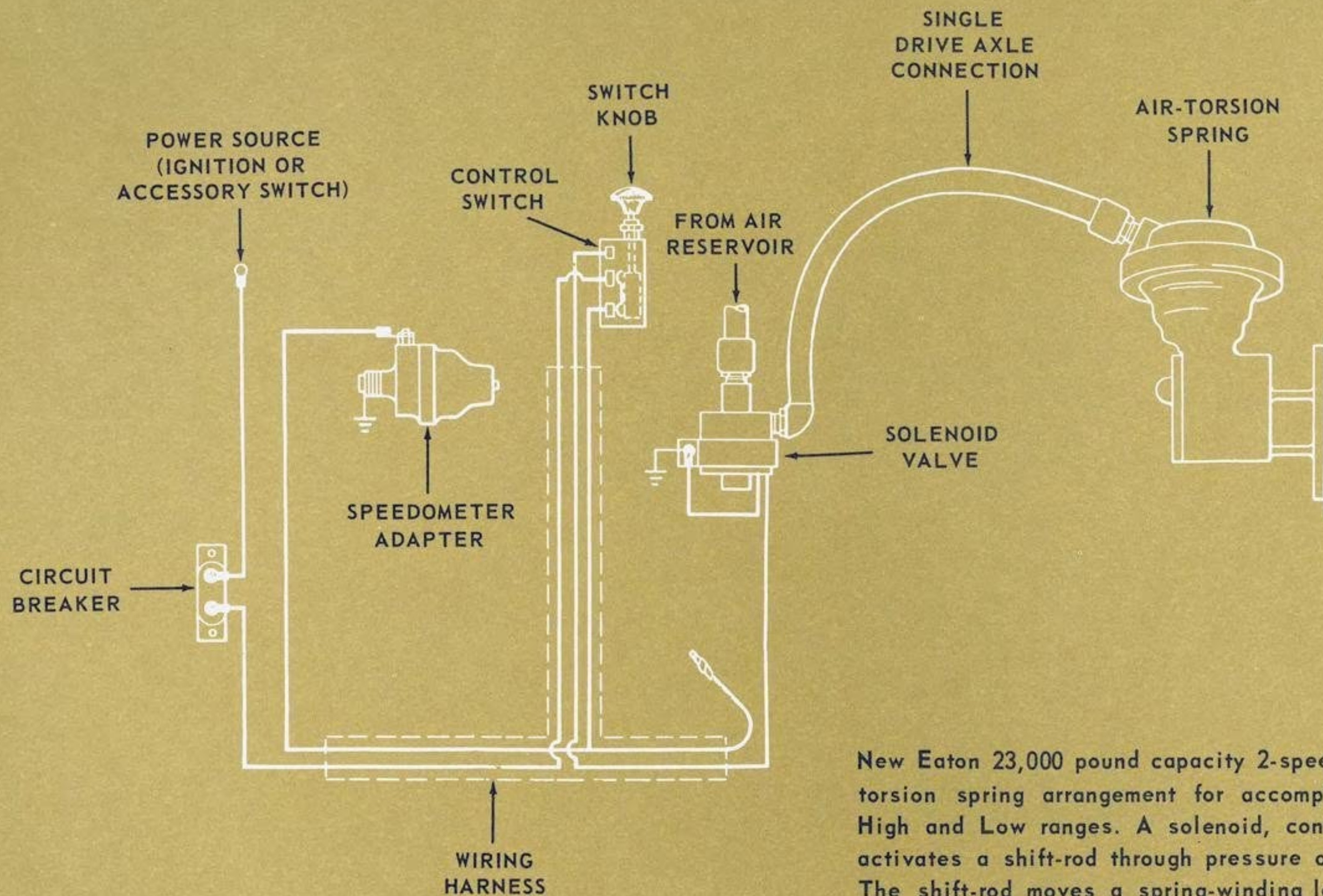

New Eaton 23,000 pound capacity 2-speed rear axles feature an air-torsion spring arrangement for accomplishing the shifts between High and Low ranges. A solenoid, controlled by a selector knob, activates a shift-rod through pressure on the shift unit diaphragm. The shift-rod moves a spring-winding lever which either winds or unwinds the torsion spring, depending on the range desired. The shift itself is accomplished when the spring is released through throttle opening or closing, or by de-clutching.

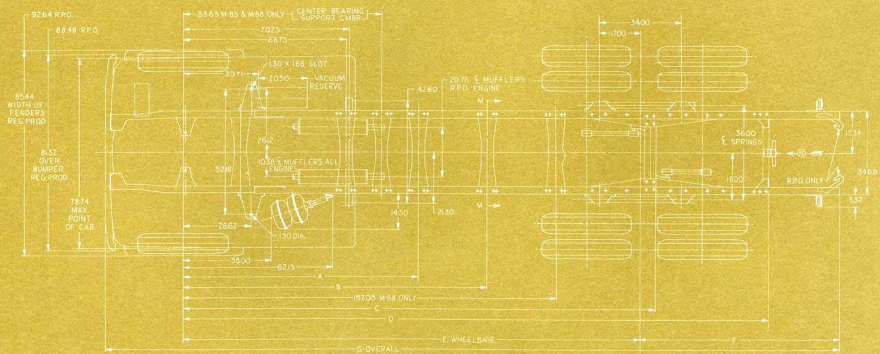

- ◆ SELF-ADJUSTING BRAKES - CKP10, 20
- ◆ 6000-MILE LUBRICATION - CP10, C20-30
- ◆ IMPROVED FRONT SPRING MOUNTING -
CLS50, CDLS60
- ◆ STOPMASTER REAR BRAKES -
23,000 LB. AXLE OPTIONS
- ◆ HEAVY-DUTY WIRING - SERIES 50, 60
- ◆ OTHER SIGNIFICANT IMPROVEMENTS

chassis

CHASSIS

The 1964 Chevrolet truck chassis, while basically unchanged from the 1963 model year, is substantially improved for greater durability and reduced maintenance requirements. The latter is evidenced in light-duty models through the extended availability of self-adjusting brakes and by a new 6000-mile lubrication interval. Other light-duty chassis refinements include improved rear shock absorbers for Series P20 and 30 models; a new front suspension stabilizer bar option for Series C10, 20, and 30 models; duo-servo front brakes on 4-wheel drive vehicles; and improved sealing of brake master cylinders.

Medium and heavy-duty chassis improvements include rubber-insulated front spring rear hangers on Series CLS50 and CDLS60 vehicles; a new front suspension rating for Series T60 models; larger diameter steering tie-rod tubes for all Series 50, 60, and 80 trucks; better air brake assembly camshaft and chamber sealing; new 15x7 Stopmaster brakes on the 23,000 pound capacity rear axles; an improved parking brake for the New Process 5-speed transmission; larger base tires for Series M80 tandem models; and the extended applicability of heavy-duty wiring harnesses to all Series 50,60 models shortly after the start of 1964 production.

FRONT SUSPENSION. CP10, C20, and C30 front suspensions are designed for the 6000-mile lubrication interval. Although basic component designs remain unchanged, special lubricants and new positive seals provide more durable, maintenance-free operation.

Neoprene rubber boot seals replace the wiping type seals previously used on the spherical joints. The upper portion of the boot seal is secured to the stud by a metal retaining ring while the lower portion seals against a nylon wear ring press-fitted to the stud. A large flow area incorporated in the new design prevents seal ballooning caused by high-pressure grease guns. Lubricant escapes through a series of openings in the molded-in nylon stiffener ring located at the base of the seal. Additionally, lower joint stud retainers are coined to provide better mating surfaces and thereby minimize spherical joint free-play in the unloaded position.

Control arm pivot shaft bushings on Series CP10, C20, and C30 models are now equipped with neoprene rubber multi-lip seals. Lubricant circulates on the inner edge of the new seal through several small peripheral lips that grip the shaft and the bushing, effectively sealing out water and other foreign materials.

Front suspension stabilizer bar equipment, standard for Series P10 models, is available on the C10, 20, and 30 models as an RPO except when these units are equipped with optional power steering, 8-19.5 tires, or dual rear wheels. The stabilizer RPO is designed for use with camper bodies or high center of gravity load applications on light-duty trucks.

New front spring rear hangers are featured on 2-1/2 inch wide spring installations for all Series 50,60 models except T60. The full-floating action of the new rubber-insulated spring hanger increases cam durability and improves front end ride. Held in place by the spring leaf ends, the new hanger cam is easily removed for replacement or maintenance and can be reversed to extend the spring ends-to-cam metal contact area wear life. In addition to the greater durability and improved ride characteristics, the new rubber-insulated hanger also provides quieter spring action.

New front suspension availability for Series T60 and T60H models, makes these comparable with other Series 60 trucks. Base equipment for T60 vehicles is a 5000 pound front axle combined with 3000 pound (each) front springs. T60H models continue to use the 7000 pound I-beam axle, but with 3500 pound (each) front springs. The 4500 pound (each) front springs are no longer mandatory for T60H models, but are still available as a free option.

Front springs of 4,500 pound capacity (each), while no longer mandatory on Series CLT80 models for either the 22,000 or 25,000 pound GVW ratings, are still available as a free option.

STEERING. Design refinements to Series C10, 20, and 30 steering systems reduce the total number of lubrication points while increasing the maintenance interval for the remaining areas to 6000 miles. Idler and pitman arm connections are now sealed units requiring no periodic maintenance. Compact, rubber-isolated type seals not only exclude dirt and water, but also provide the important functions of transmitting steering forces and cushioning road shocks.

Tie-rod ends, while basically unchanged for 1964, achieve the 6000-mile lubrication interval through the use of a special lubricant in combination with sliding-type rubber seals.

Tie-rod tube diameters are increased on all Series 50, 60, and 80 trucks for both standard and RPO steering applications. The larger, more durable tie-rod tube protects against buckling at the center portion of the tube.

REAR SUSPENSION. Series P20 and P30 models feature malleable cast iron rear shock absorber brackets which replace the stamped steel brackets used previously. The new cast bracket results in improved bracket-to-frame load distribution, eliminating the need for the bracket-frame reinforcements formerly used. Also, shock absorber extended length is increased 1/2-inch for both the base and optional shock absorber applications. The extended length, also applicable to C38 models, improves ride and guards against suspension bottoming in the jounce condition.

BRAKES. Brake improvements for 1964 are concentrated in the areas of reduced maintenance and increased reliability. Refinements are apparent throughout the model line-up in both the hydraulic and air braking systems.

Self-adjusting brakes at all four wheel locations are provided as base equipment for Series CKP10 and 20 trucks. The linkage-type adjusting mechanism, similar to that introduced in 1963 for Corvaire 95 vehicles, eliminates the need for periodic manual maintenance and assures more consistent pedal response.

Actuated automatically during reverse stops, the mechanism functions only when the brakes need adjustment. Mounted on the secondary shoe, the self-adjusting unit is attached at one end to the anchor pin by a heavy wire link while, at the other end, a pawl contacts the adjusting screw star-wheel.

The mechanism is activated by shoe movement which occurs during reverse stops. If the lining wear is sufficient to cause a predetermined amount of movement, the pawl turns the adjusting screw star-wheel, thus spreading the brake shoes apart as in manual brake adjustments.

Duo-servo type brakes replace non-servo (Lockheed) brakes on the front driving axles of all 4-wheel drive vehicles, resulting in better effectiveness, smoother operation, and improved reserve. Formerly, duo-servo brakes were provided only at the rear wheels.

Better sealing and greater standardization are achieved through a new master cylinder design common to both passenger car and light-duty trucks. Inclusion of a diaphragm type seal inside the reservoir cover and usage of a spring-clip cover retainer both contribute to better system sealing. Application of the new master cylinder design includes the light-duty truck power brake cylinder option, J70, in which the master cylinder is integral with the power unit.

Reliability of the hydraulic brake system is improved by new

piping and wheel cylinder connections for Series 50 and 60 models. The brake lines are now seated directly in the wheel cylinders, eliminating the swivel-type fittings formerly used and therefore minimizing the possibility of poor connections occurring at these points during installation of the piping system.

Addition of synthetic rubber type seals at both ends of the front brake assembly camshaft and chamber bracket increases component reliability for air brake equipped models. One seal located at the slack adjuster keeps water out of the bracket while another similar type seal at the cam inhibits grease entry.

Air-actuated, Rockwell-Standard, 15 x 7-inch Stopmaster brakes are used with 23,000 pound rear axle options for Series 80 models. Brake lining area, per assembly, for the Stopmaster brake is 220 square inches. Durability and performance features of the Stopmaster design include: Tapered linings which are 3/4-inch thick at the maximum point, providing more lining thickness at the point of greatest wear for longer lining life; balanced shoe action, whereby both shoes do equal work, resulting in increased drum life and reduced bearing stress; cool operating temperatures, reducing fade while extending drum and lining life; heavy-duty backing plates of rigid, cast-spider construction, providing good durability; completely sealed actuating units for minimum maintenance.

The Stopmaster unit employs the wedge principle as the method of brake actuation. Air pressure in the chamber moves the diaphragm plate assembly, causing downward motion of the actuating rod. The rod, wedge-shaped at the plunger end, moves between two rollers, causing uniform pressure of each roller upon anchor plungers. Four anchor plungers, actuated by two wedge assemblies, contact the two brake shoes, one at each shoe end, resulting in the uniform braking action.

Mandatory in 1964 with the new, optional 34,000 pound heavy-duty tandem suspensions for Series MW80 models are 15 x 7 full air brakes.

A design refinement of the New Process 5-speed transmission parking brake results in reduced maintenance and longer component life. Improved drum positioning is achieved through a new bar type anchor support design which not only maintains the drum location but inhibits the loosening of the rear bearing retainer bolts.

WHEELS and TIRES. Base tire size for Series M80 models is increased from 8-22.5-8PR to 9-22.5-10PR, making the

CHASSIS

Series 80 tandem vehicles compatible with other Series 80 models in this respect. RPO S08 (7.50-20-10PR rayon tires) and RPO S10 (7.50-20-10PR nylon tires), used with 20x6-inch cast wheels, are no longer available for Series M80 models.

Other tire changes for 1964 include new, larger highway rayon 11.00-20-12PR tube type or 12-22.5-12PR tubeless tires in combination with 20x7.5 or 22.5x8.25 cast wheels available for optional use only when 23,000 pound rear axles are specified on Series 80 models. Additionally, optional 11-22.5-12PR tubeless tires in combination with 22.5x7.50 cast wheels are required for Series MW80 models with the new, optional 34,000 pound heavy-duty tandem suspensions.

ELECTRICAL SYSTEM. Applicability of the special wiring harnesses introduced in 1963 as standard equipment for Series D60 and all Series 80 models and as a mandatory option for Series 60H models is extended to include shortly after the start of 1964 production on a regular production basis Series 50 models and the remainder of the Series 60 models, including the 60H models. Components affected are the main wiring harness, instrument cluster harness, front extension harness, and engine wiring harness. Individual leads in these harnesses not protected by fuses feature a special synthetic rubber insulation rather than vinyl insulation. If a short circuit or overload occurs in any of these leads, the heat generated is localized by the non-melting insulation, protecting the surrounding wires.

Additionally, as an extension of the 24-month or 24,000-mile warranty program, headlights and miniature lights for all models, including Corvair 95's, feature improved durability with increased filament size.

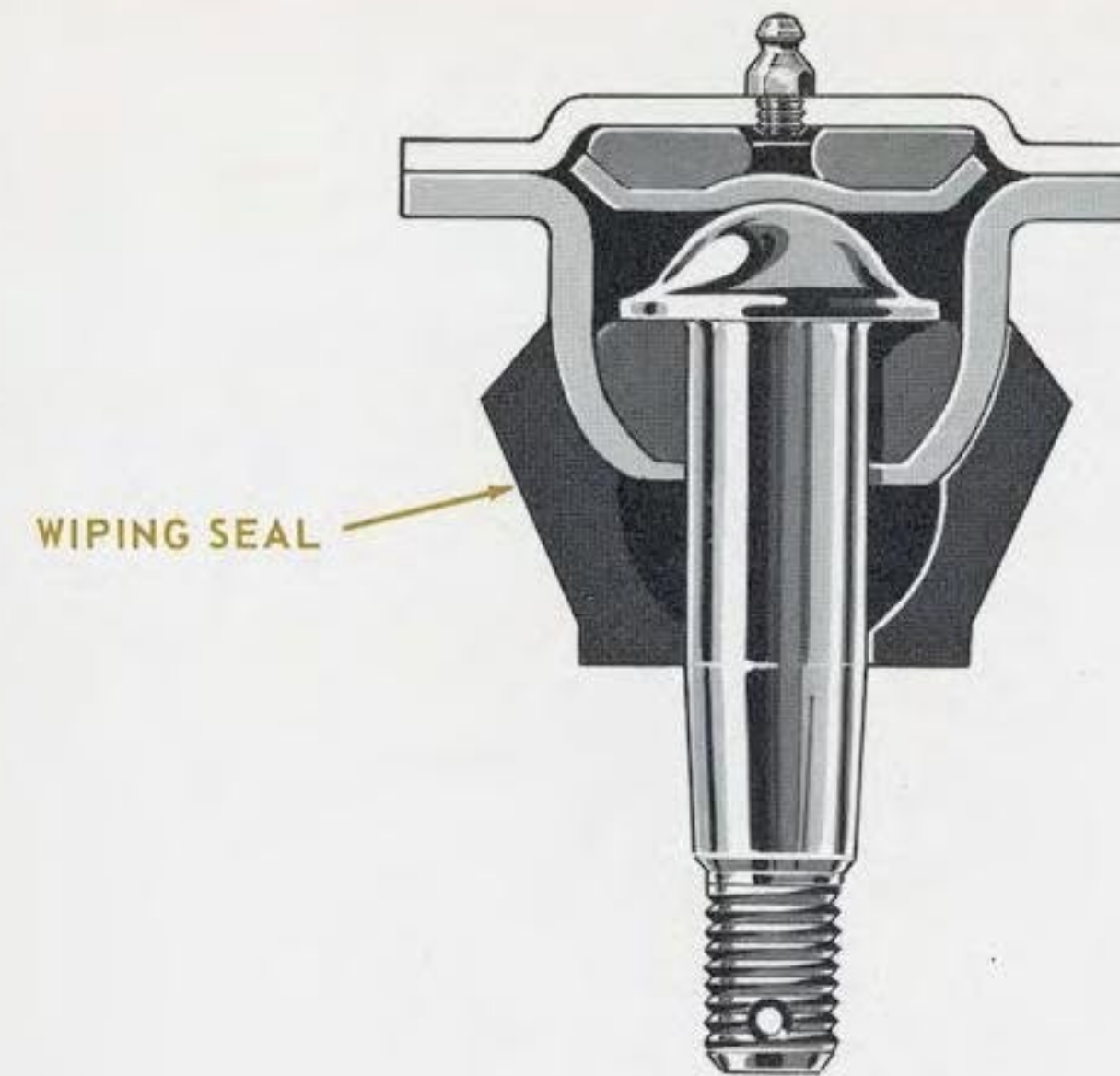

1963 SPHERICAL JOINT

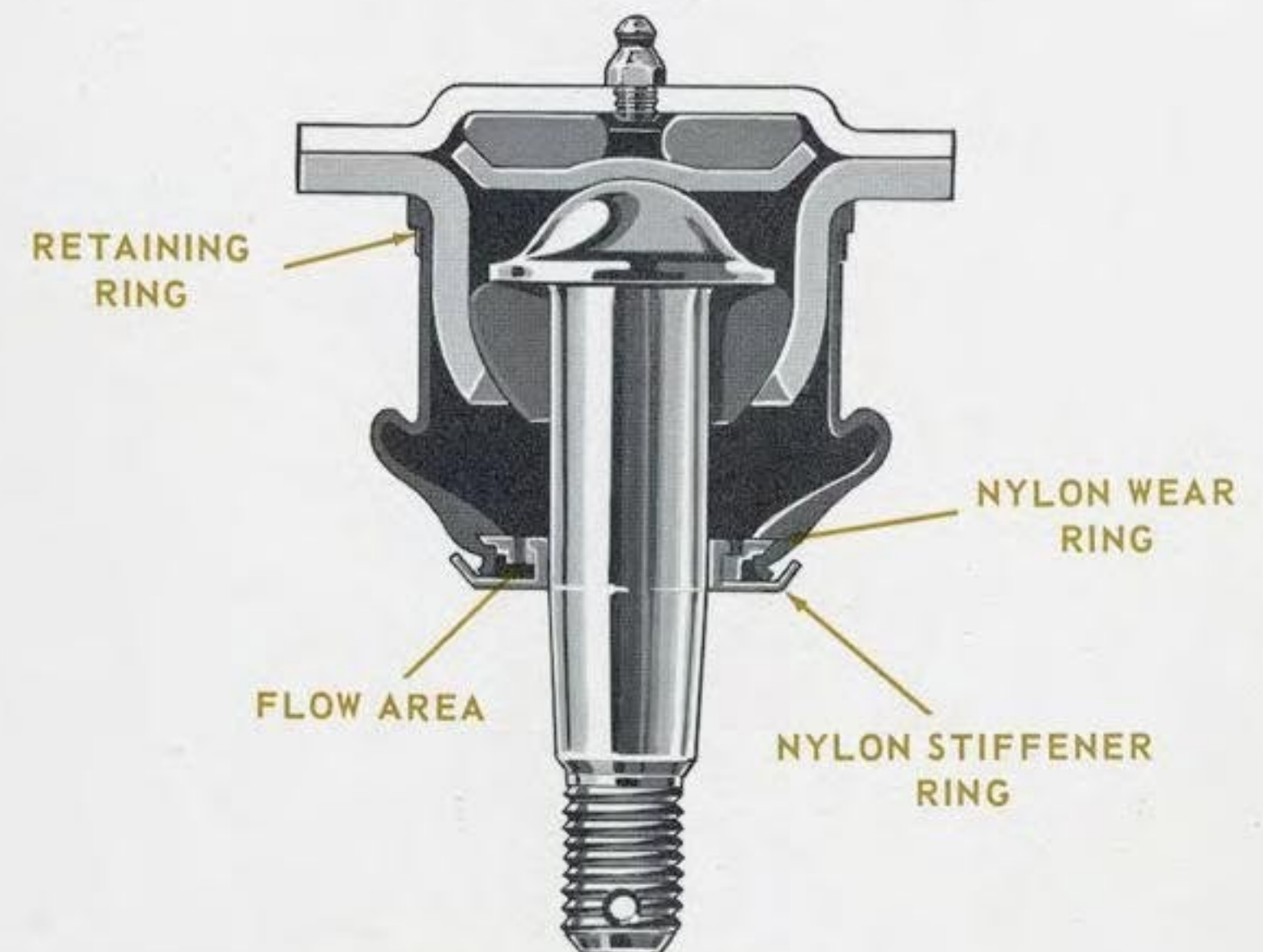

1964 SPHERICAL JOINT

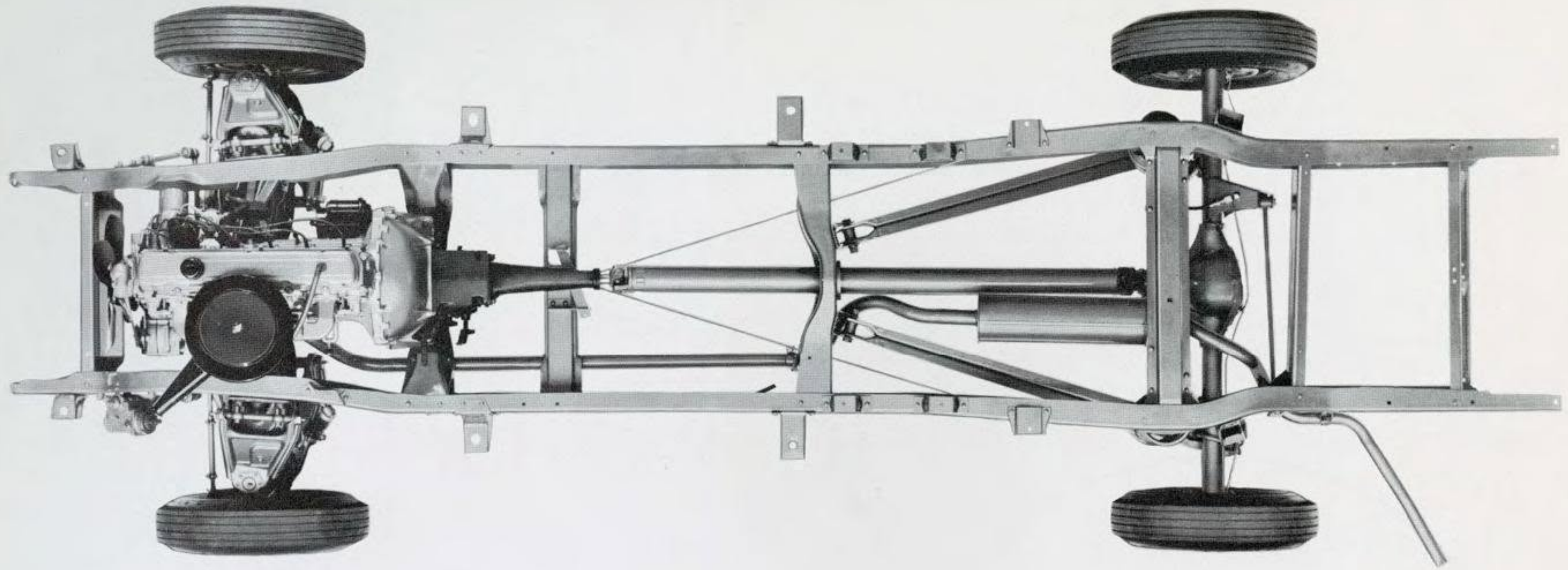

6000-MILE CHASSIS LUBRICATION

Under normal operating conditions, Series CP10, C20, and C30 trucks need only be lubricated each 6000 miles. Design refinements, plus the application of new seals and improved lubricants, result in the extended lubrication interval. Additionally, certain areas are permanently-sealed and therefore service-free. These include steering system idler arm-to-relay rod connections and pitman arm-to-relay rod ball studs, plus some universal joint applications.

Advantages of the longer lubrication interval are reduced vehicle downtime, lower maintenance costs, and improved component life. The latter is achieved inherently because of the lessened chance of omitted or improper maintenance.

New positive-type seals combined with long-life lubricants promote better sealing and contaminant exclusion at the critical chassis areas. Multi-lip type pivot shaft bushing seals and neoprene rubber

boot-type spherical joint seals contribute to longer-lasting front suspension lubrication.

The 6000-mile spherical joint seal design (shown at the left) replaces the wiping type seal previously used. Secured to the stud by a retaining ring at the upper location, and by a press-fitted nylon wear ring at the lower attaching point, the neoprene seal incorporates a large flow area to reduce seal ballooning. Openings in the nylon stiffener ring allow discharge when fresh or excessive lubricant is applied.

Certain chassis areas require no change in achieving the 6000-mile interval. These include fluid check-points (engine, transmission, rear axle, steering gear, engine distributor oiler, and brake main cylinder) as well as low wear areas such as leaf-spring front and rear hangers.

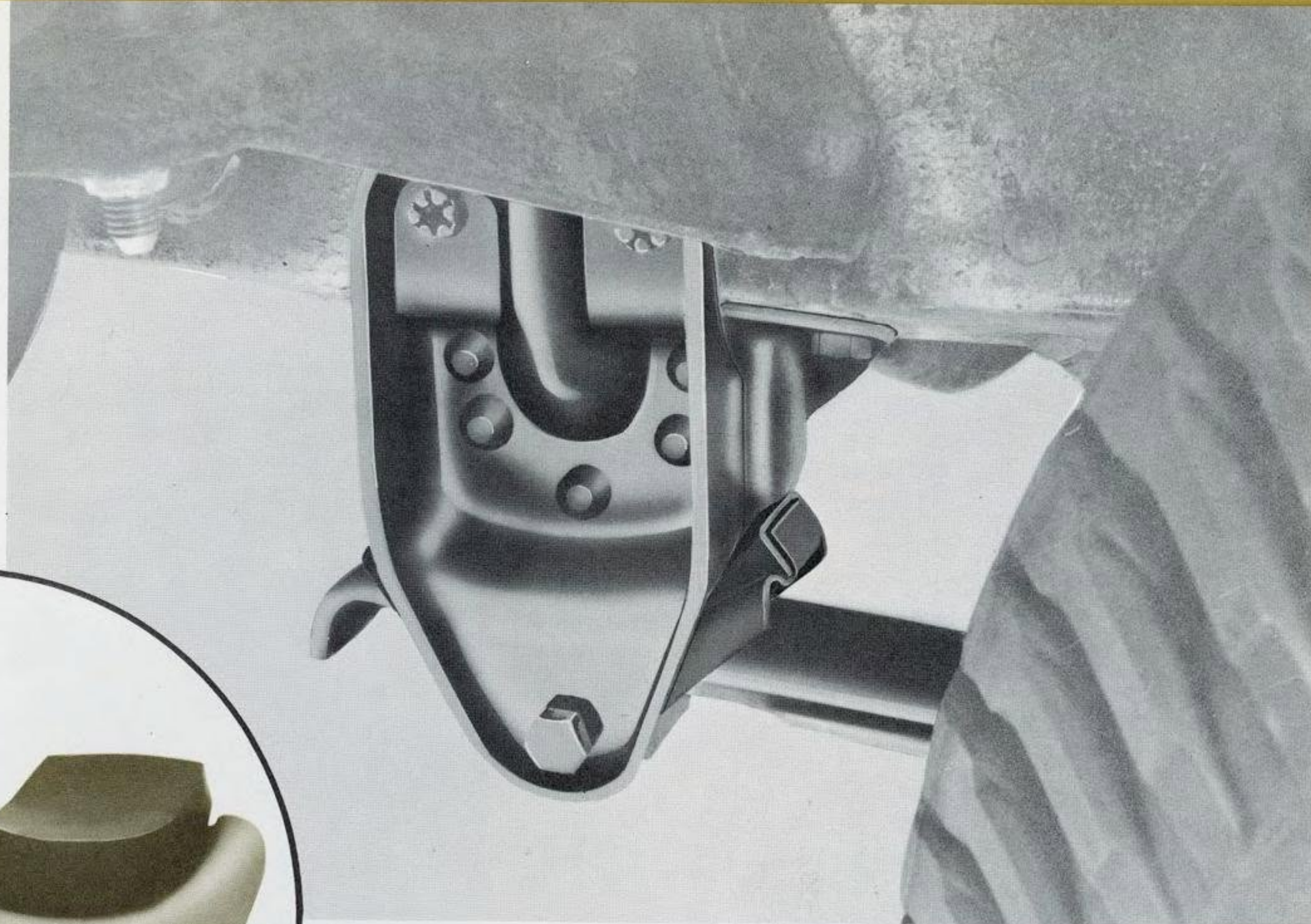

A new front spring rear hanger cam design is used for medium-duty truck 2-1/2 inch wide spring installations. The new cam is full-floating for improved ride characteristics; rubber-insulated for quieter operation; reversible for longer life; and removable for easy maintenance.

IMPROVED SPRING MOUNTING

BRAKE FEATURES

Reduced maintenance and improved pedal response are achieved for Series CKP10 and 20 trucks through self-adjusting brakes at all four wheel locations. A linkage system, comprised essentially of a wire link and stamped pawl, is permanently secured at the anchor pin and is mounted on the brake secondary shoe. Actuated during reverse stoppage and only when adjustment is required, the pawl end automatically turns the adjusting screw star-wheel.

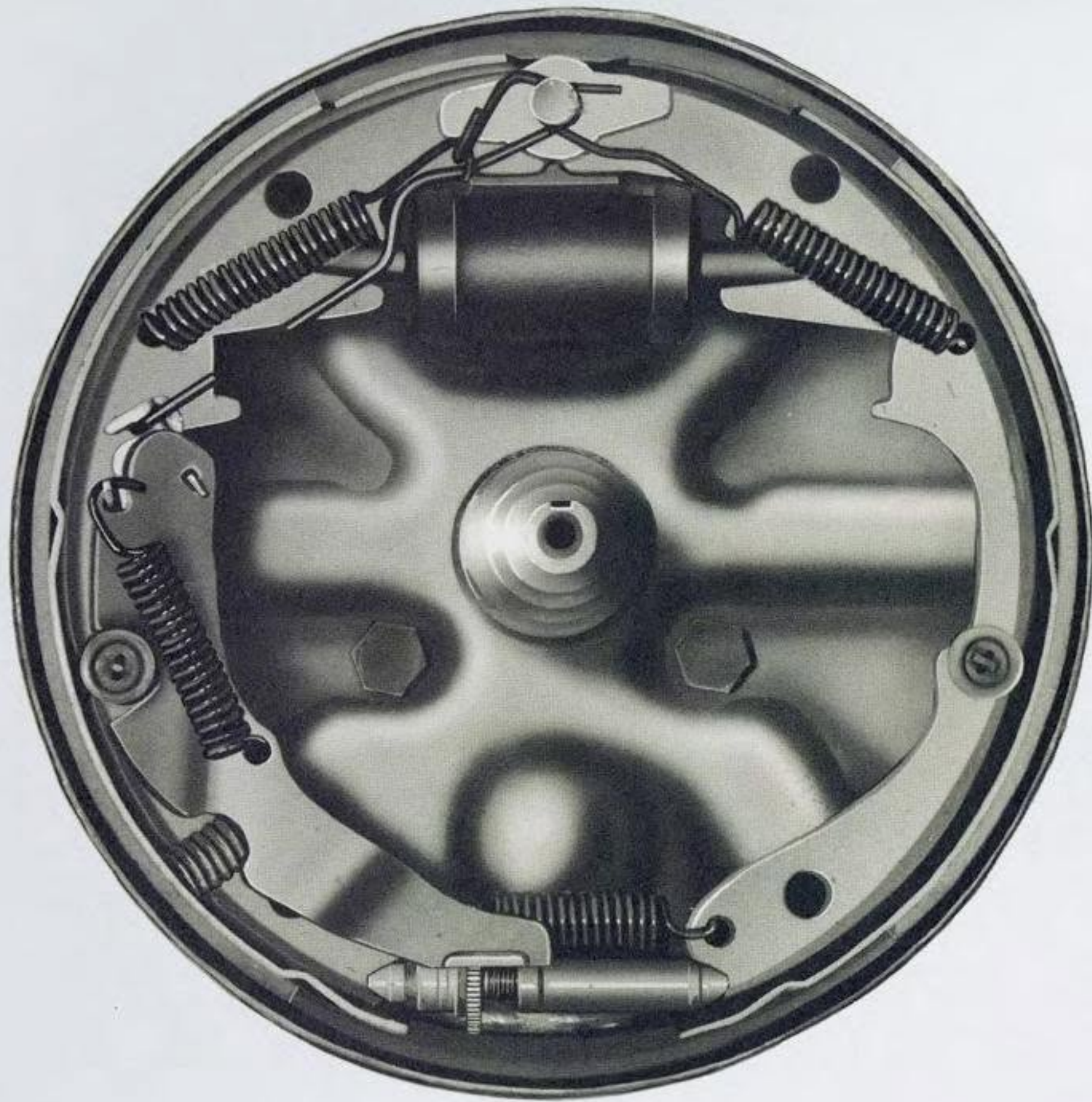

Rockwell-Standard 15x7-inch Stopmaster wedge-actuated, floating-shoe type brakes are provided at the rear wheel locations as part of the 23,000 pound rear axle option for Series 80 models. Balanced shoe action results when the air chamber wedge (shown at the right), forced down by the diaphragm plate assembly, spreads two rollers apart, each roller causing uniform plunger movement against its respective shoe end. Other advantages of the Stopmaster design include long lining life, cool operating temperatures, completely sealed actuating units, and durable backing plates.

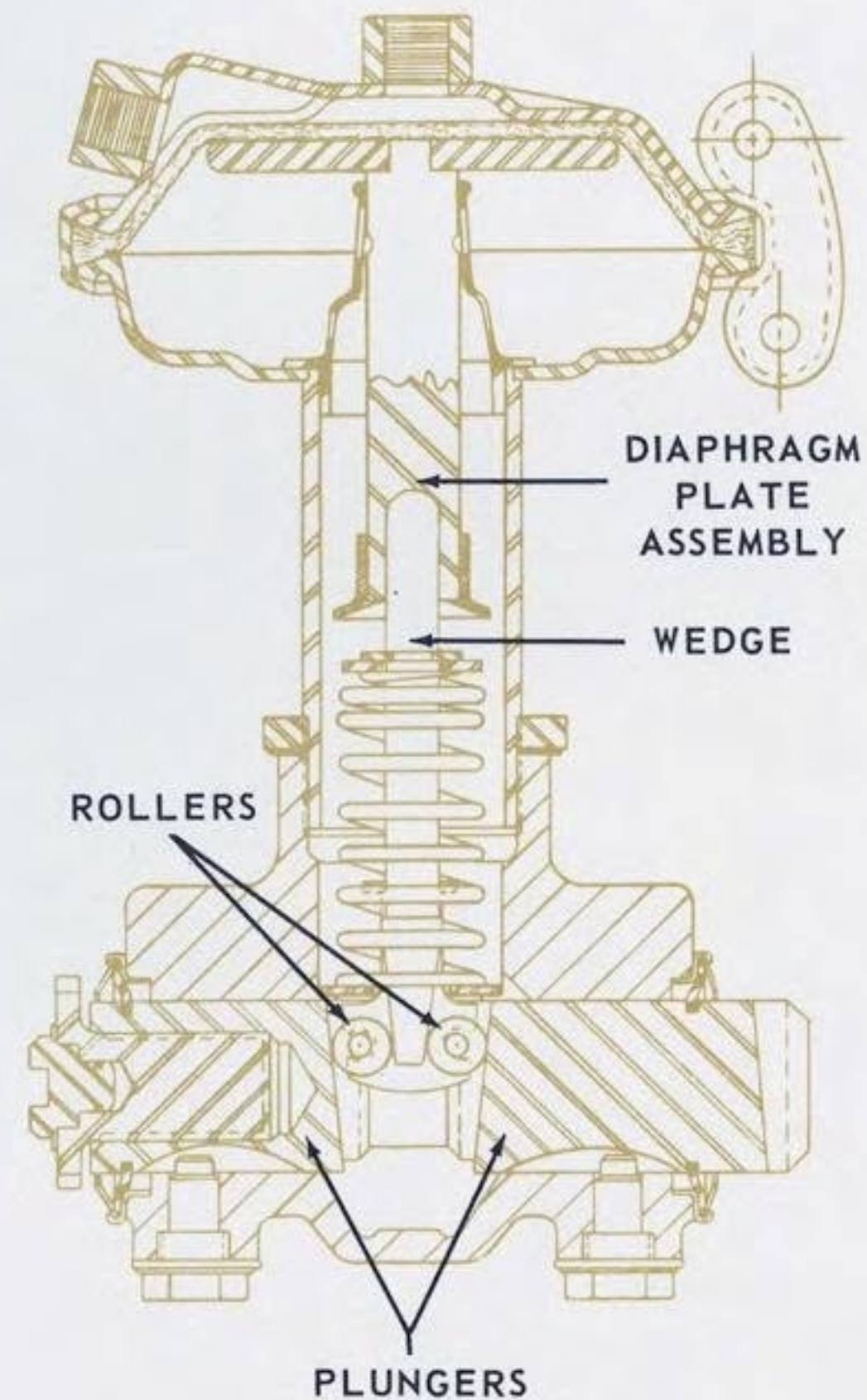

- ◆ TWO SERIES, TWO BASIC MODELS
- ◆ SCULPTURED PASSENGER CAR STYLING
- ◆ ALL-STEEL BODY
- ◆ FULL-COIL SPRING SUSPENSION
- ◆ CHOICE OF 14 POWER TEAMS

the el camino

SEDAN PICKUP

EL CAMINO STYLING



MODEL 5380

The sleek styling of the El Camino body lines are highlighted in the front view with a vehicle-wide radiator grille of silver anodized aluminum and bright moldings around the grille opening.

Raised embossments add interest to the hood expanse, and the central wind-split is capped with a bright molding on Model 55-5680. Bright windshield reveal moldings and a chrome bumper with integral parking lights complete the front view.

The sleek styling line is continued with curved side window glass and sculptured body metal enhanced with brightwork such as the ventipane and post and rocker panel molding. Chrome hub caps are regular production equipment.

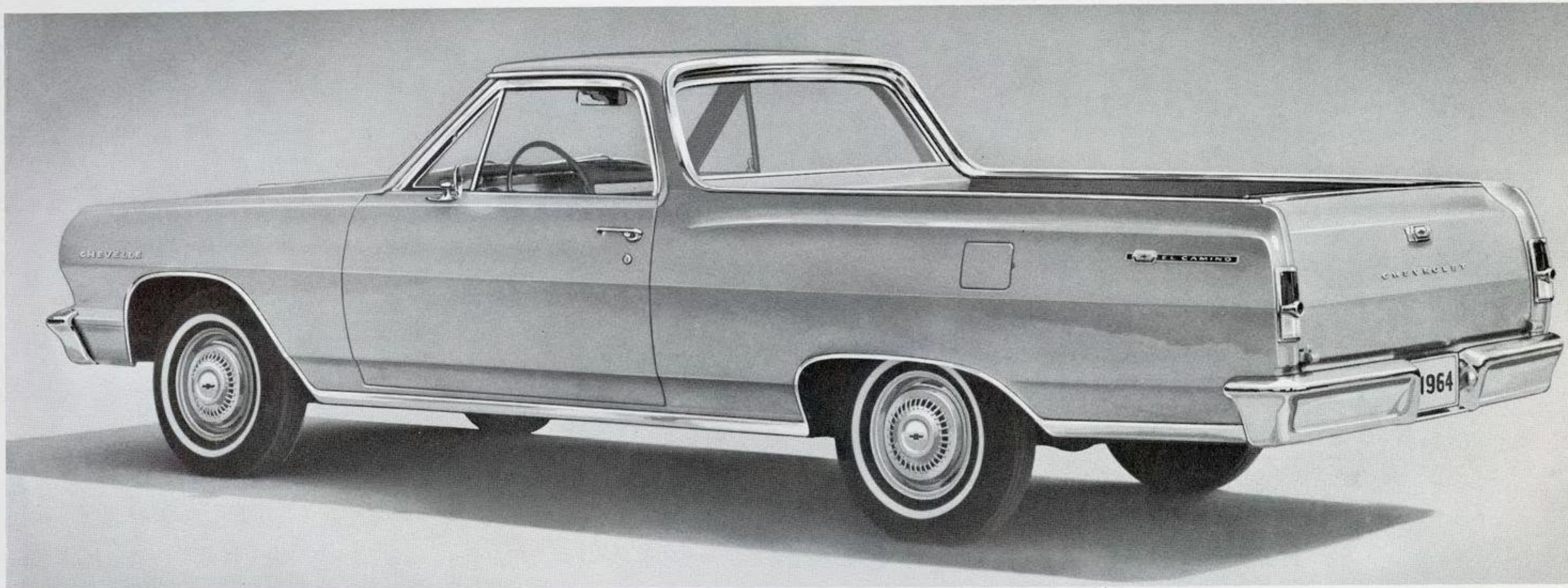

MODEL 5580

Tasteful application of brightwork also enhances the rear view. The bright roof line moldings, pickup box and tailgate top moldings, and rear window reveal moldings are common to both Model 53-5480 and Model 55-5680. Distinguishing Model 55-5680 are bright moldings for the wheel openings, lower rear pickup box, roof drip gutter, door upper frame, and windshield pillar.

Integrated with the styling configuration of the pickup box ends are combination tail and back-up lamps. Dummy lenses are provided for the back-up lamp portion of the assemblies when this optional equipment is not specified.

A wrap-around chrome bumper completes the rear view.

EL CAMINO STYLING

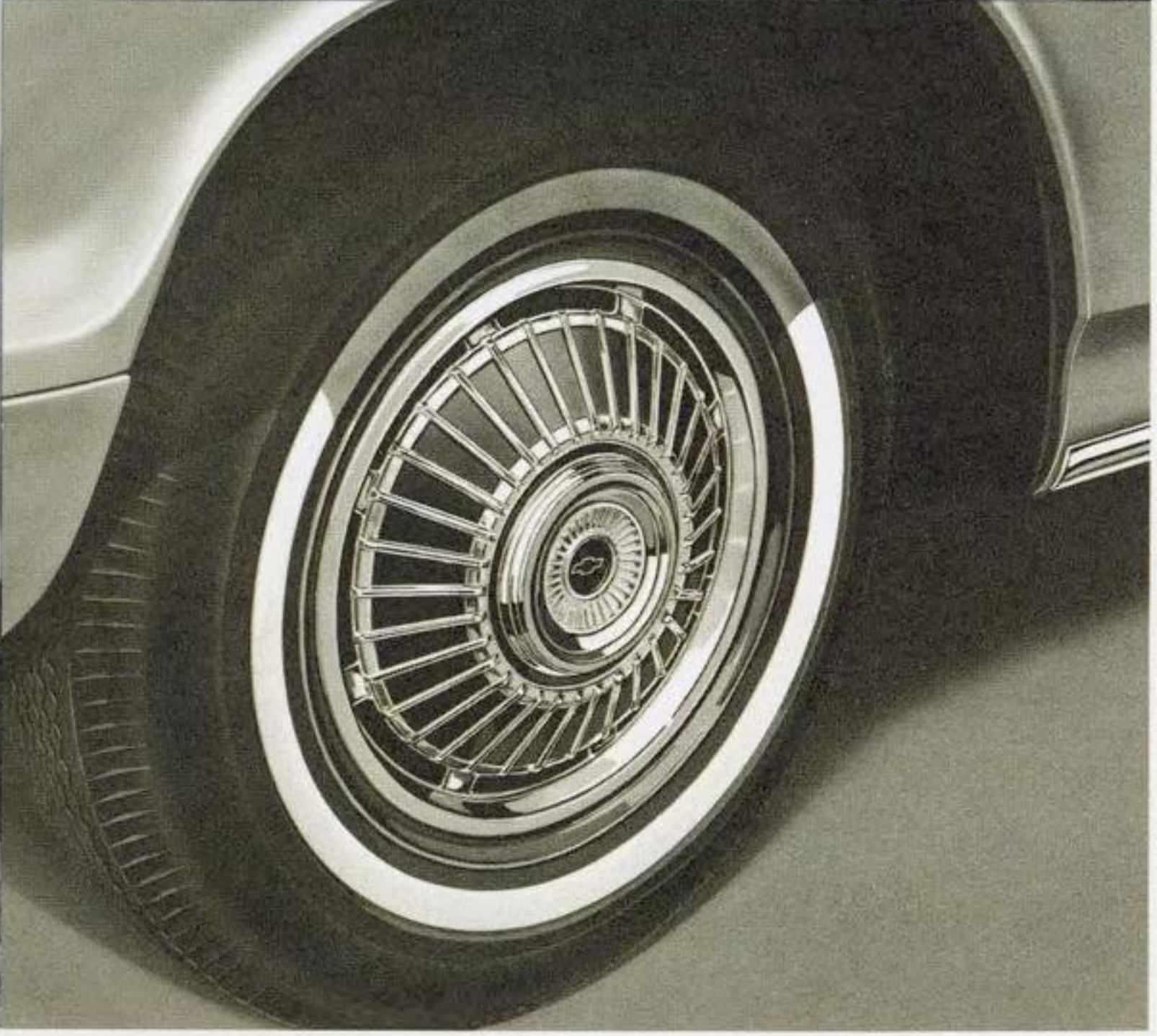
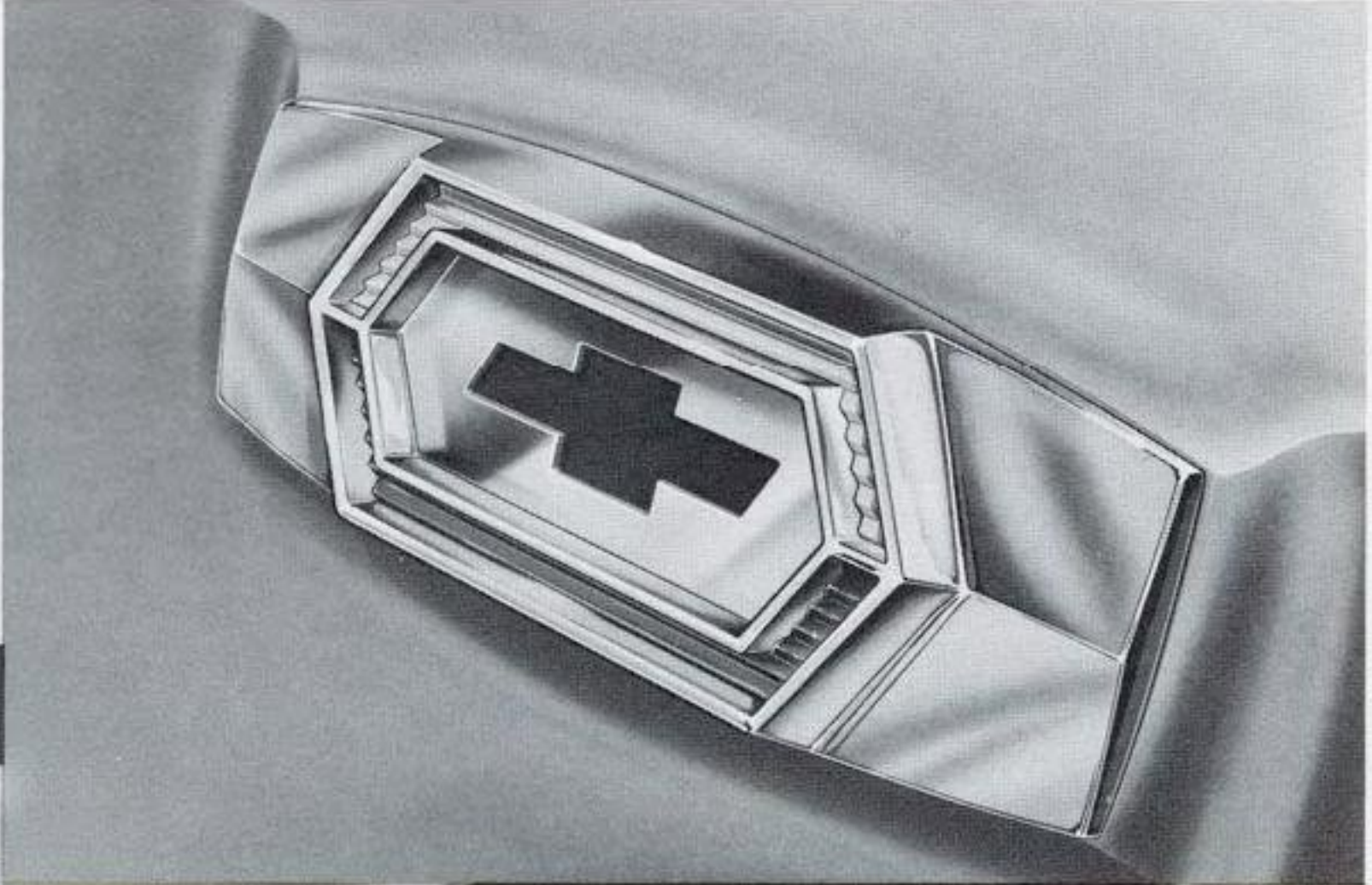

Black paint accents add interest to the simply-styled regular production chrome hub caps. Body color – a choice of 14 solid colors are offered – is used for the wheels. Whitewall tires are optional equipment.

El Camino models with an 8-cylinder engine carry a V-emblem on the lower rear portion of the front fenders. The chrome emblem is decorated with Red, White, and Blue color fill. Another emblem is provided models with the optional 230 cubic inch 6-cylinder engine.

El Camino models carry on the front fenders a chrome series nameplate identifying them as models in the new Chevelle line.

Both El Camino models are readily identified by the distinctive nameplate carried at the upper rear of the pickup box side panels. Chrome letters contrast against a Black ground for emphasis, and the decorative medallion is accented with a Black emblem on a Silver ground. The medallion upper field is White, while the lower field is Red.

A chrome emblem carrying a Black Chevrolet trademark is centered on the tailgate outer panel. The depressed border around the trademark is decorated with Gold paint at the top and Black paint at the bottom.

Chrome-plated, stainless-steel accessory wheel trim disks with Black paint trim enhance the El Camino exterior appearance. The central plastic insert carries Black, Silver, and chrome accents.

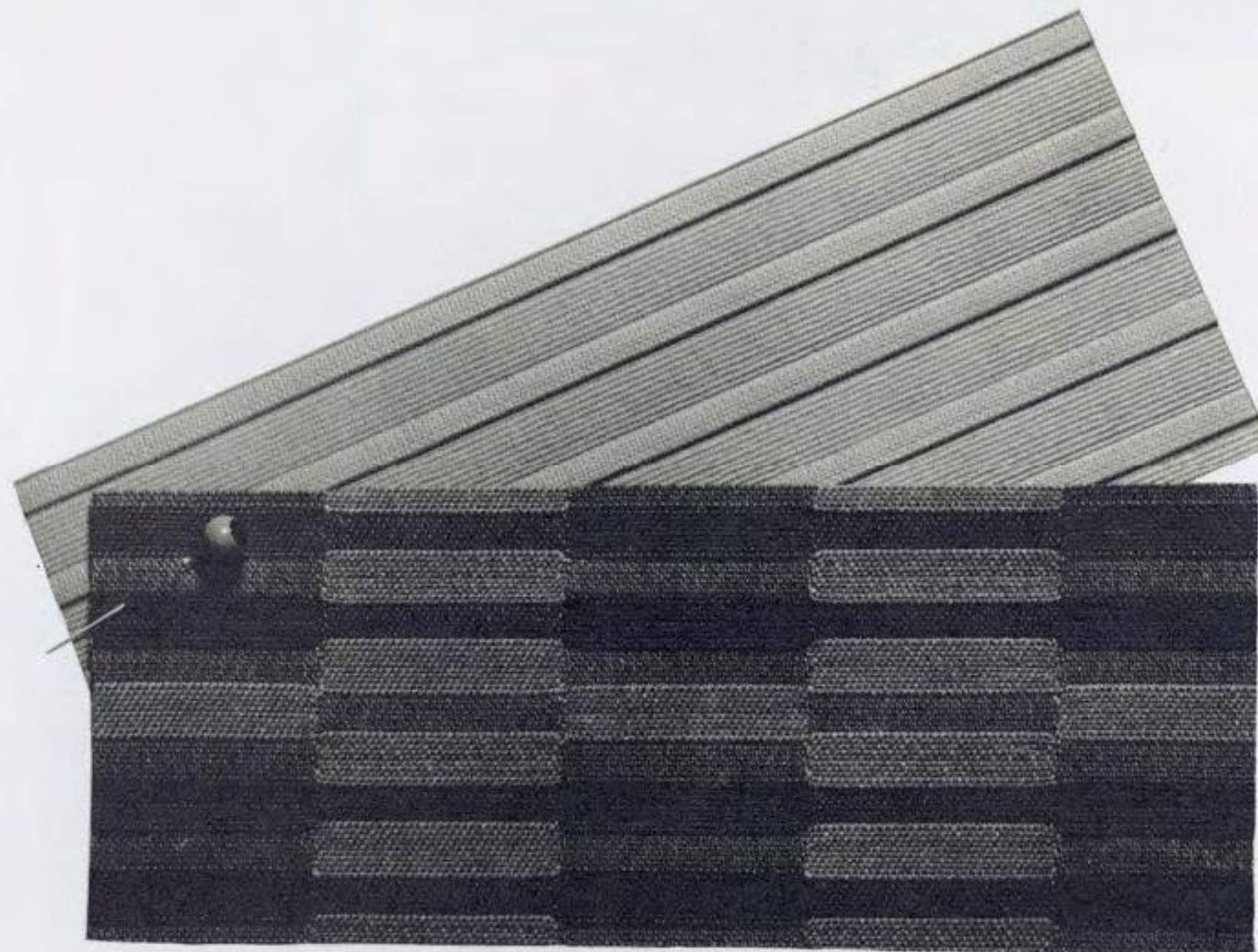

El Camino interiors are color-keyed to the exterior and are offered in either Fawn, Aqua, or Red. Both models utilize vinyl sidewall trim, dual sunshades, dual armrests, a chrome half-circle horn ring, bright trim plates for the instrument panel cluster area and glove box door, a cigarette lighter, vinyl headlining, and door jamb switches for automatic dome lamp actuation.

All-vinyl seat trim with vertically-embossed coverings is used for the 53-5480 interior, while the 55-5680 interior features seat trim comprised of basket-weave cloth coverings and vinyl facings. (See covering swatches illustrated above.) Further distinguishing the 55-5680 interior — shown at the right — are special sidewall

treatment, including special door hardware and armrests; carpeting; 2-tone steering wheel paint treatment (except with Red interior); vinyl-covered sunshades, special vinyl headlining; clock; glove box light; and bright seat end moldings. Optional bucket seats of leather-grain vinyl with bright outer moldings are available for the 55-5680 interior. Included with this option is a matching vinyl cover for the spare wheel and tire.

The 53-5480 interior also features a special sidewall treatment, including door hardware and armrests. Black rubber floor mats with spatter-color treatment and hardboard sunshades are utilized.



EL CAMINO BODY

An integrated cab and pickup box design is employed for the El Camino body structure, which features box-sectioned major structural components, steel pickup box floor, cemented-in windshield and rear window, and double-wall cowl and pickup box. The body is separate from the frame for improved ride and road isolation. Ten double rubber-biscuit type mounts are used to connect the body to the frame.

Roof pillars, headers, and rails are of box-section design for strength, and are welded to the solid roof panel to form a structurally sound greenhouse for glass openings. The instrument panel is welded to the center plenum chamber and hinge pillars, forming a strong structural tie. The underbody, tying all upper sheet metal panels together, is heavily ribbed and formed for maximum strength. Rigid double panel construction is employed for the pickup box and tailgate. Saddle-bag type ventilation with cowl top air entry is featured, as well as air-dried, water-washed rocker panels.

Both windshield and rear window are cemented directly to

the window opening flange, forming a more positive seal than the conventional rubber weatherstrip. The seal is comprised of a 2-part rubber compound, an adhesive and a catalyst. General appearance of the openings is improved since bright metal moldings fit tightly to the glass with the seal virtually hidden.

Curved side door window glass enhances vehicle styling. The doors are of double-panel construction and utilize new, fork-type locks which positively latch to a stud-type striker. Inside push-button locks and outside key locks for both doors are featured.

Protective inner fender skirts, similar to those of regular Chevrolet passenger cars, are used for the El Camino. The double-type fender protects the outer fender inner surface from the corrosive effects of road dust, slush, and mud. A full-length member connecting the radiator support panel to the dash panel fastens to the fender and fender skirt for structural strength.

Double-panel construction is employed for the hood which is hinged at the rear and counterbalanced. The hood is opened with an external release.

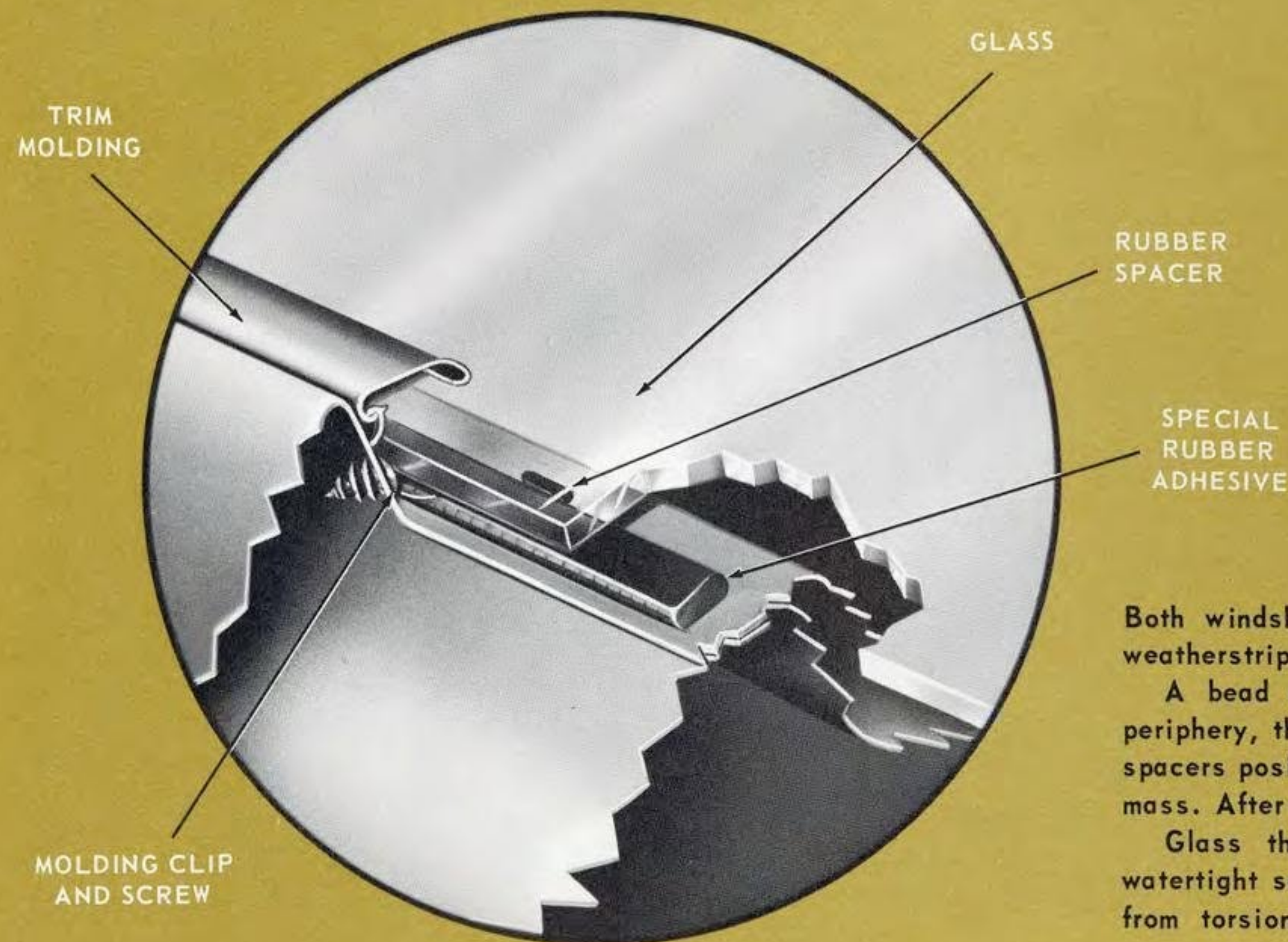

Both windshield and rear window are cemented in place, eliminating weatherstripping for improved sealing and appearance.

A bead of special rubber adhesive is applied to the inner glass periphery, then the glass is installed within the opening. Small rubber spacers position the glass until the adhesive cures to a tough, resilient mass. After curing, trim moldings are attached with clips and screws.

Glass thus cemented to the pinch-weld opening will maintain a watertight seal in field use and be less susceptible to strain-breakage from torsional and beaming forces encountered in vehicle operation.

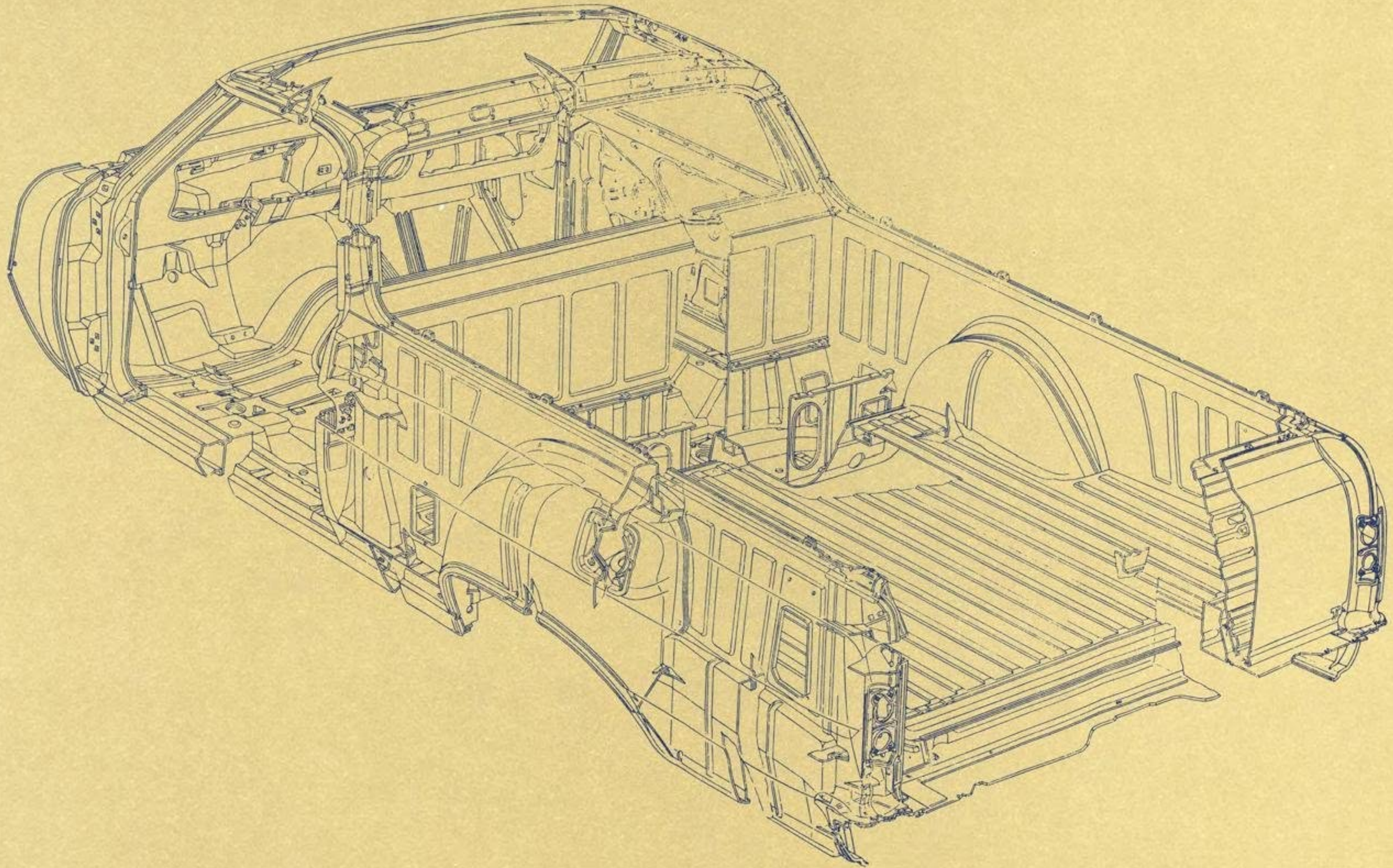

EL CAMINO POWER TRAIN

A wide variety of power team combinations is available for El Camino models to satisfy individual preference with regard to economy, performance, or utility. Provided are four engines, two 6-cylinders and two V-8 units; four transmissions, a 3-speed, 4-speed, Powerglide, and Overdrive; and three axle ratios.

ENGINES. El Camino Models 53-5580 are equipped with a 194 cubic inch displacement L-6 engine with a 230 cubic inch displacement, 6-cylinder unit available optionally. El Camino Models 54-5680 feature a 283 cubic inch V-8 engine equipped with a 2-barrel carburetor; optional on these models is a 4-barrel carburetor, dual-exhaust version of this same engine.

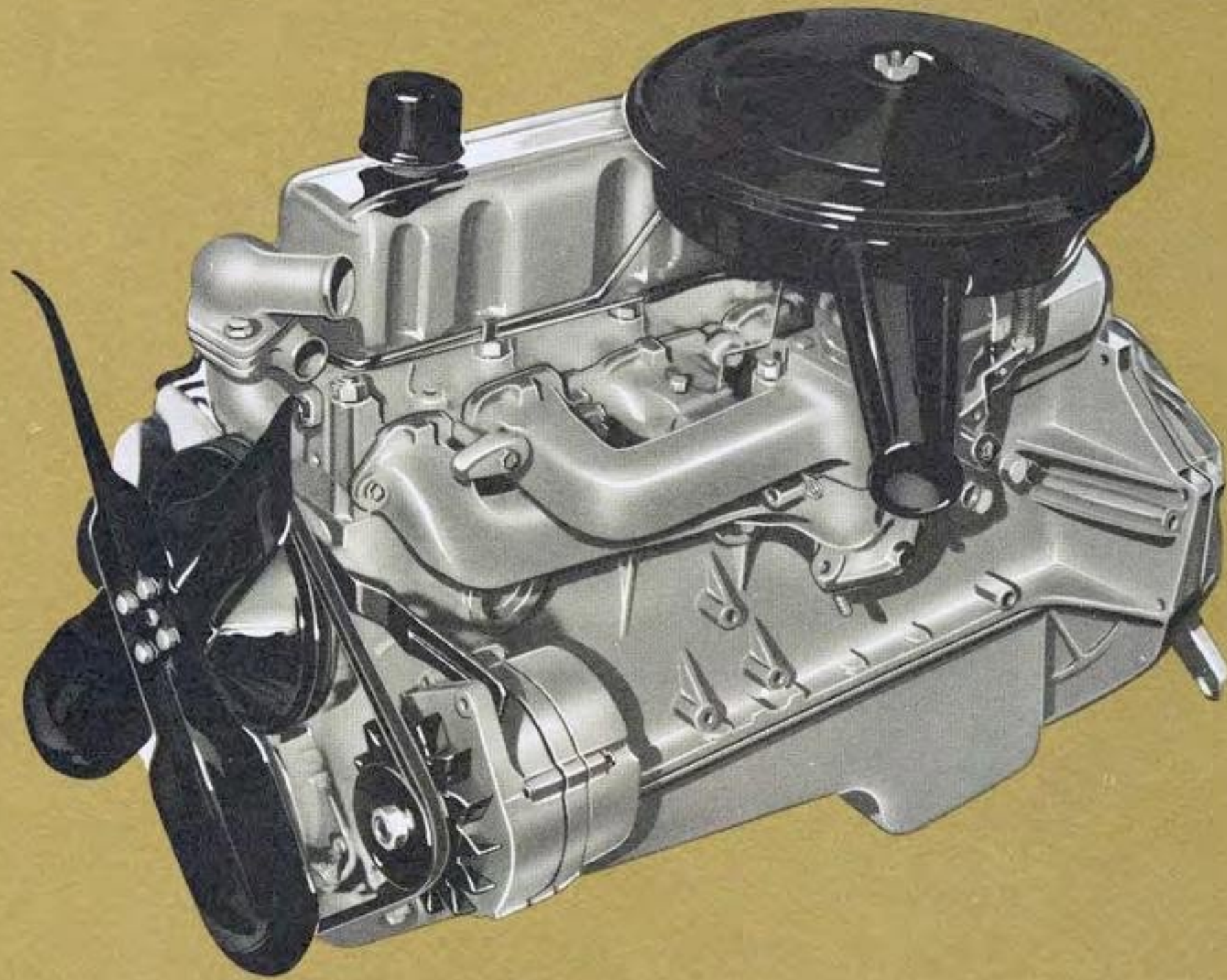

HI-THRIFT 194 ENGINE

The Hi-Thrift 194 engine carries the same output ratings and basic design as the 1963 Chevy II unit, but is modified to fit the El Camino chassis configuration. The front crossmember location on the El Camino requires moving the oil pan drop-section rearward. For accessibility, the oil dip-stick gauge is moved rear-

ward to extend through the starter brace mounting boss on the cylinder block. Additional firmness for the clutch linkage cross-shaft is provided by a long horizontal boss cast integral with the left rear flange.

The optional 230 cubic inch Turbo-Thrift is similarly modified from the 1963 passenger car design with a revised oil pan and relocated oil dip-stick. The engine also is distinguishable by a bright metal rocker cover, oil filler cap, air cleaner cover, oil dip-stick handle, and fuel and vacuum lines.

The Turbo-Fire 283 V-8 has the same output ratings as in 1963. A new automatic choke control similar to the one used on the 1963 194 cubic inch L-6 is used. The temperature-sensing

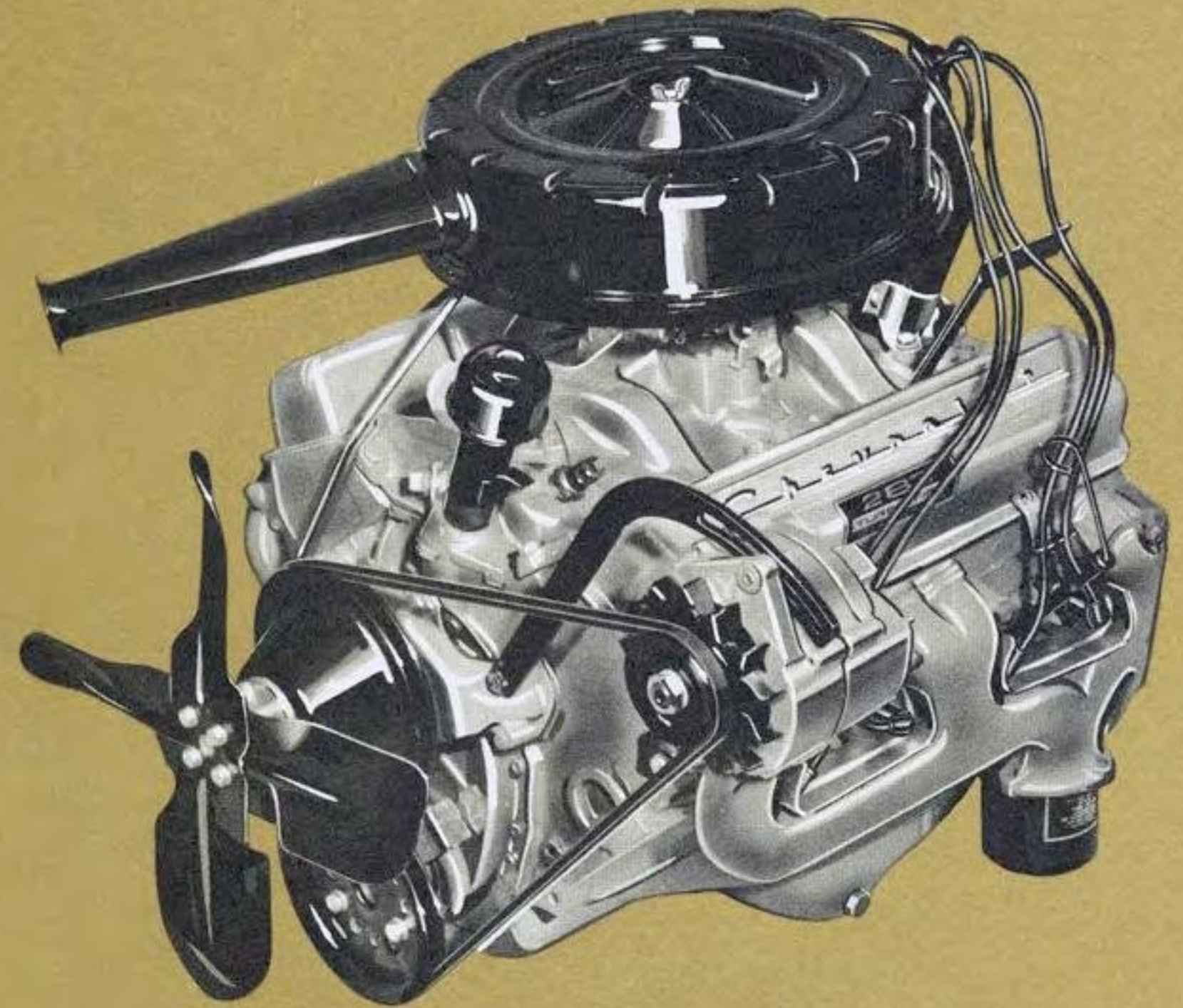

TURBO-FIRE 283 ENGINE

unit is mounted in a heat stove cast into the inlet manifold exhaust crossover passage and actuates a vertical rod connected to the carburetor choke valve. The new heat supply arrangement enables a diaphragm vacuum control unit to be used in place of the previous piston control for greater reliability.

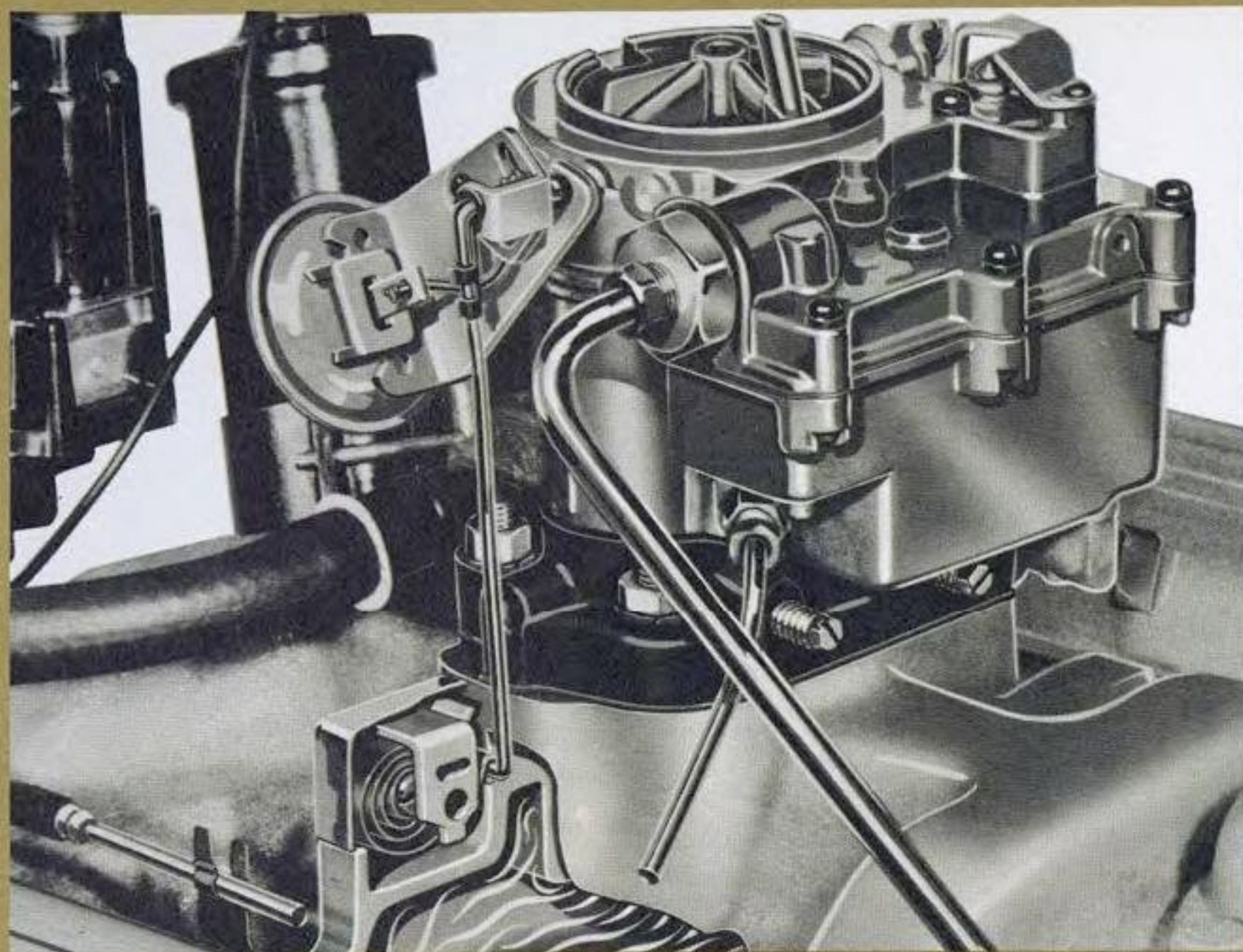

V-8 AUTOMATIC CHOKE CONTROL

The ram's horn design previously used on the 283 cubic inch V-8 exhaust manifold is replaced by rear outlet manifolds. Instead of sweeping upward, the new manifolds curve downward passing below the spark plugs, providing better service accessibility. Oil pan configuration also is revised with the drain plug on the left lower side. All available engines are equipped with a stronger die-cast aluminum clutch housing.

Exhaust manifold outlets and pipes are two inches in diameter. Mufflers are of the same oval-type used for regular production units, but length is increased 4.5 inches. As a rust prevention measure, stainless steel components are utilized on the cold, right hand side and aluminized components on the hot, left hand side.

TRANSMISSIONS. El Camino models feature a transmission line-up which includes 3 and 4-speed synchromesh, Overdrive, and Powerglide automatic units. The 3-speed manual transmission, synchronized in second and third gears, is base equipment for all models. Available optionally with both 6 and 8-cylinder engines are Powerglide and Overdrive transmissions. Also available

optionally, but only with the V-8 engine, is the 4-speed manual transmission, synchronized in all forward gears. Ratios for both the 3 and 4-speed manual transmissions are as follows:

	3-Speed		4-Speed
	6-cyl.	8-cyl.	8-cyl.
First	2.94	2.58	2.56
Second	1.68	1.48	1.91
Third	1.00	1.00	1.48
Fourth	- -	- -	1.00
Reverse	2.94	2.58	2.64

Available with the base equipment 3-speed transmission is the planetary gear type Overdrive unit which, through its 0.7-to-1 ratio, reduces engine speed for better fuel economy, lower noise level, and longer engine life. The Overdrive transmission may be manually locked out by the operator through a hand control, or by fully-depressing the accelerator pedal.

An air-cooled version of the 2-speed Powerglide automatic transmission is available with 6-cylinder engines and has a maximum torque converter ratio of 2.40-to-1. A converter ratio of 2.10-to-1 is provided for the water-cooled Powerglide used only for models with 8-cylinder engines. All units feature 1.82-to-1 gear ratios in both low and reverse gears.

Shift control levers are steering column-mounted for all transmissions, except the 4-speed which uses a floor-shift-type common to other light-duty trucks.

DRIVELINE. El Camino models utilize a single 3-1/4 inch diameter propeller shaft with yoke and trunnion universal joints at each end for all driveline applications.

REAR AXLES. El Camino models equipped with manual or automatic transmissions utilize a 2700-pound capacity, Salisbury-type rear axle with ratios of 3.36-to-1 for 6-cylinder units and 3.08-to-1 for 8-cylinder units. Overdrive transmission equipped units use a special 3.70-to-1 ratio. Hypoid gearing is utilized for quiet differential operation and long life. The differential is of 2-pinion design, with a ring gear diameter of 8-1/4 inches. The Positraction limited-slip type differential is available as an extra-cost option with no change in axle ratios. Also available optionally for 8-cylinder models with a 3-speed transmission is the 3.36-to-1 axle ratio.

EL CAMINO CHASSIS

FRAME. The El Camino utilizes a perimeter-type frame of welded construction. Full-length side rails, joined laterally by three crossmembers, comprise the basic frame configuration.

With the exception of a small area rearward of the rear suspension crossmember, the side rails are durable, closed box-sections. These sweep inboard at areas of critical stress at the front and rear suspension mountings. Side rail box-sections widen at these areas to provide extra strength where it is needed.

In the area of the engine, the inboard sweep of the side rails forms a torque-box tie into the front suspension crossmember which has a closed hat-section and is the foundation for both the front suspension and steering systems. As it connects to the frame, it forms the upper end of the shock absorber tower and the upper control arm attaching point. At the frame rear kick-up, a wide Z-shaped, stamped crossmember connects the side rails and supports the rear suspension. A standard channel section crossmember connects the side rails at the rear of the frame.

The lower control arms of the 4-link rear suspension attach to brackets welded on the frame side rails at a point just forward of the intermediate crossmember, while the upper control arms attach directly to it. A large plate, welded to both the side rails and the intermediate crossmember, forms the upper spring seat to which the rear shock absorbers mount.

FRONT SUSPENSION. The independent front suspension system of the El Camino is a version of the short and long arm type, similar to that used on full-sized Chevrolet passenger cars. Stamped control arms, coil springs, special sealed pivot points, and a standard stabilizer bar are compatibly designed to give the El Camino excellent ride and handling characteristics.

The coil springs, mounted between the lower arms and the towers formed in the front crossmember, include concentrically-positioned shock absorbers.

The control arms, designed for maximum strength with minimum weight, are wishbone-shaped, channel-section, heavy-gauge metal stampings and attach to the steering knuckles with non-metallic lined spherical joints. The lower arm, the primary load-carrying member, features a tension-type spherical joint, and the upper arm, a compression joint unit. The four spherical joints require lubrication only every 6,000 miles under normal driving conditions. Control arm pivot shafts are permanently-sealed components with compressed rubber bushings.

A conventional link-type stabilizer bar is standard equipment

on El Camino models to provide additional resistance to roll without any increase in spring rates. The stabilizer bar is mounted at the lower control arms with rubber-bushed links and at the frame with four bolt brackets.

Brake dive and lateral suspension movements are minimized by the engineered compatibility of control arms and spherical joints. Road shocks are adequately absorbed through controlled-deflection, rubber-isolated pivot points specifically designed to give the maximum in good ride qualities with minimum maintenance requirements.

STEERING. The El Camino is equipped with a conventional relay-type steering linkage and recirculating ball-type steering gear with a 24-to-1 steering gear ratio. The four tie-rod ends are to be lubricated at 6,000 mile intervals. As in the Chevrolet passenger car design, the other steering pivot and attaching points are permanently-sealed units which require no periodic maintenance. A feature of the system is a compact, rubber-isolated, low-friction nylon bearing pitman-to-relay rod joint. The design of this joint promotes the efficient cushioning of road shocks with effective steering force transmission.

El Camino power steering, available optionally, is an integral system with the power cylinder and rotary control valves built into the steering gear. The power steering gear assembly is the recirculating ball type with a ratio of 17.5-to-1. In the integral system, the ball nut functions as a 2-way power cylinder which acts on the sector shaft in turning the wheels. The rotary valve power steering gear gives precise, positive steering with very little driver effort.

REAR SUSPENSION. The 4-link rear suspension design of the new El Camino models, utilizing frictionless coil springing, provides excellent ride and load-carrying characteristics. Additionally, air-inflatable shock absorbers permit a degree of tailoring of the wheel rates and vehicle rear trim.

Two relatively-long stamped channel-section lower control arms extend from brackets at each end of the axle housing to brackets at the start of the frame rail kick-up. Each control arm end pivots in compressed rubber bushings. Shorter stamped-channel section upper control arms mount on brackets attached to the differential housing, extend diagonally outward to brackets on the intermediate Z-shaped crossmember and restrict lateral axle movement relative to the frame. Like the lower control

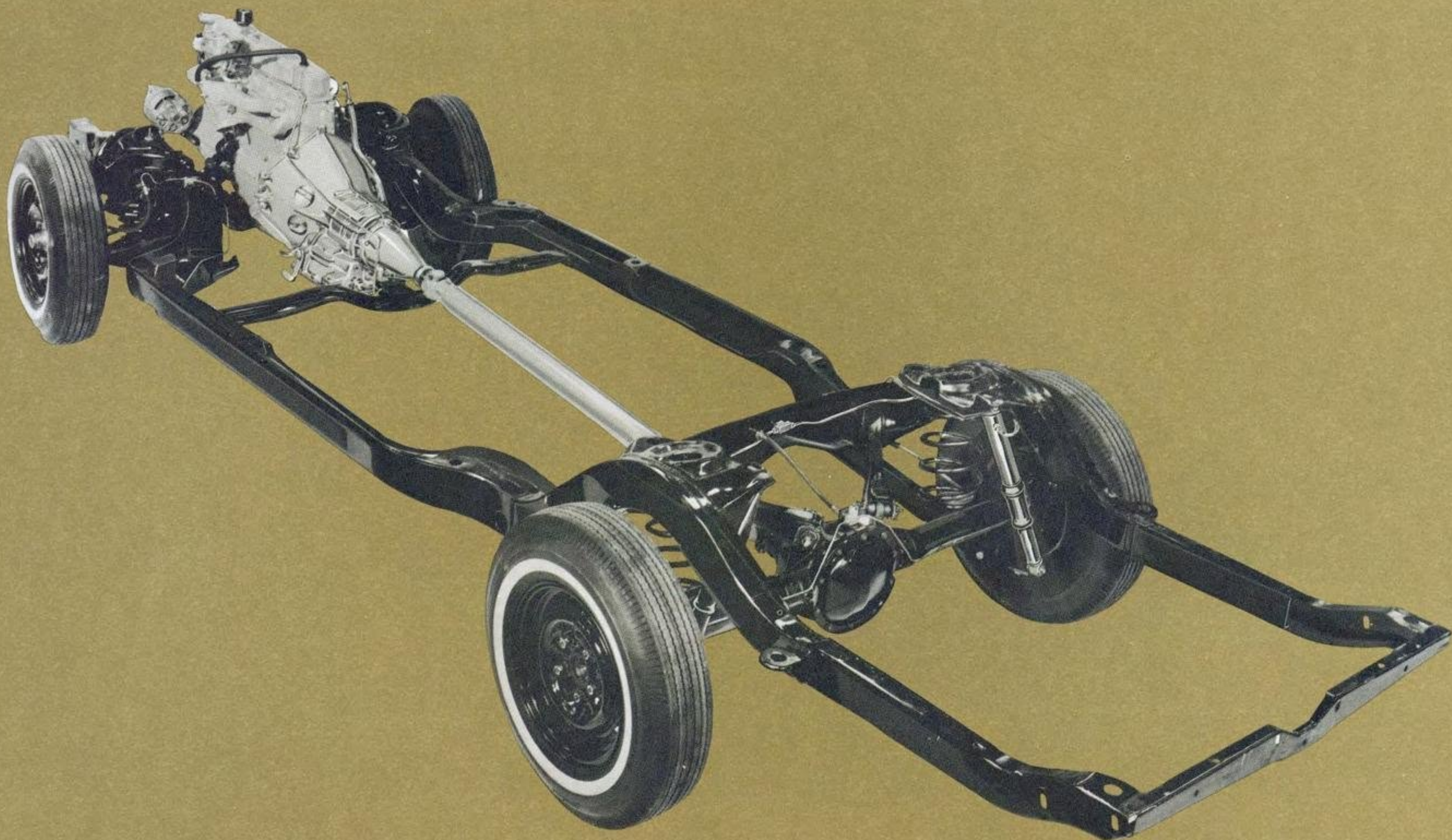

EL CAMINO CHASSIS

arms, each end of the upper arms pivots in compressed rubber bushings.

Coil springs are positioned directly over the axle housing. The lower spring seat is welded to the axle housing, and the upper to the frame side rail and to the intermediate crossmember. With the springs mounted in this fashion, vertical loading and travel occurs along the spring axis, directly between two primary structures, with a minimum of distortion and side loading.

The El Camino chassis also features Delco air booster shock absorbers as standard equipment. The shock absorbers extend diagonally and are mounted conventionally at the upper spring seat plate and at the lower control arm mounting bracket extension. The diagonal positioning of the shock absorbers adds substantially to vehicle stability and roll control.

The shock absorbers are of the conventional, hydraulic, direct-acting type, but encircled by inflatable air chambers. Varying the chamber air pressure extends or retracts the piston, changing the wheel rate to keep the vehicle level under different load applications. The air feed lines to each shock absorber connect to a tee on the intermediate crossmember. These lines also equalize the pressure in each air chamber, balancing the two units. From the tee, another air feed line connects to a tire-type valve mounted adjacent to the spare tire in the cab. By adding or re-

leasing air via the same method used in maintaining correct tire pressure, the shock absorbers can be adjusted to meet changing road and load conditions. When the shock absorbers are fully inflated, El Camino load capacity is increased by 500 pounds.

BRAKES. Self-adjusting, 9-1/2x2-1/2 inch front and 9-1/2x2-inch rear hydraulic duo-servo type brakes are used for El Camino models. Bonded brake linings of molded asbestos material provide a total effective lining area of 172.7 square inches. Bore diameters are 1.0 inch for the single chamber master cylinder and 1.06 inch front with 0.875 inch rear for the wheel cylinders.

Brake options include a power-assist unit, integral with the master cylinder, and metallic brake linings for severe service operations. Pulley-cable linkage to the rear wheels constitutes the parking brake system. Application is by a foot pedal-type control below the instrument panel, left of the steering column.

WHEELS & TIRES. El Camino models are equipped with 7.00-14-4PR (2-ply construction) tubeless highway rayon tires in combination with 14x5J short-spoke-type disk wheels having a 4.75-inch bolt circle and a 5-stud, 7/16-inch diameter attachment. Extra-cost tire options include narrow-band-type whitewall tires for improved vehicle appearance.

AIR BOOSTER REAR SHOCK ABSORBERS



El Camino load capacity is increased by 500 pounds when the standard equipment air-booster rear shock absorbers are fully inflated.

Encircled by inflatable air chambers, the shock absorbers can be adjusted by varying the air pressure to meet different road and load conditions. Air pressure is varied through a tire-type air valve mounted adjacent to the spare tire in the cab. From the air valve, air feed lines connect to each unit through a tee on the intermediate frame crossmember. The air feed lines to the shocks also serve as balance hoses to equalize the pressure in each air chamber.

INTERIM 1963 CHANGES

MODELS

Six new models are added to the 1963 truck model line-up, extending the total model count to 184 from 178. Total wheel-base count remains at 19. The new models -- all in the Series 60 category -- are comprised of three conventional trailing axle tandem models and three conventional tilt-cab models.

The new tilt-cab models are: Model T6903S, Model T6903, and Model T6903H; all have a wheelbase of 175 inches. GVW ratings and equipment are identical to other Series T60 models.

The new trailing axle tandem models are: Model M6303 with a wheelbase of 157 inches; Model M6503 with a wheelbase of 175 inches; and Model M6803 with a wheelbase of 193 inches. Base GVW of these models is 24,000 pounds, while maximum GVW is 30,000 pounds. Maximum GCW is 35,000 pounds; minimum GCW is 28,000 pounds.

SERIES M60 DETAILS. The M60 frame design is similar to that utilized for M80 models. Series 60 engine mounting brackets are used, however, to accommodate the base 292 L-6 engine. Heavy-Duty Frame Equipment, optional for other Series 60 vehicles, is not available for M60 models since it is an inherent part of all Series 80 frames.

Base front suspension for M60 models is the 5000 pound front axle with 4000 pound (each) front springs. The larger capacity springs, optional equipment for other Series 60 models, are utilized for purposes of improved vehicle trim as well as front end durability.

Available optionally is the 7000 pound front axle with 3500 pound (each) front springs. Also obtainable as a separate option for use with the 7000 pound front axle are 4500 pound (each) front springs.

A bogie rating of 28,000 pounds is achieved for the M60 vehicles through the use of a forward driving Chevrolet 15,000 pound rear axle in tandem with a Chevrolet trailing axle. The standard driving axle is basically the same 15,000 pound, single-speed, 7.2-to-1 ratio rear axle used for other Series 60 vehicles. Available optionally is the Chevrolet 15,000 pound, 2-speed, 6.40/8.72-to-1 ratio rear axle also utilized for other Series 60 trucks.

The trailing axle consists of a tubular member 77.47 inches long with a 4-1/2 inch O.D. and a wall thickness of 0.50 inch. Welded to the member at a point approximately 10-1/2 inches

from each end are 7-1/2 inch diameter flanges which attach through six 9/16-inch diameter bolts to the brake backing plates. The axle outer spindle ends are finished to accommodate conventional Series 60 rear hub and drum assemblies. Both inner and outer wheel bearings are of the Hyatt barrel-roller design.

A new version of the Hendrickson-type tandem rear suspension is utilized for M60 models. The Hendrickson design, similar to that utilized for M80 trucks, offers distinct features in addition to increased payload capacity and better load distribution.

Axle driving forces and braking forces are transmitted to the chassis through torque rods and equalizing beams. Torque rods permit complete absorption of torque, which is the tendency of the axles to turn backward or forward on their neutral axes due to starting or stopping inertia. Equalizing beams, suspended below the axles, absorb strain, twist, and road shock in addition to maintaining an equal division of weight at all times to each axle regardless of load conditions. The beam action allows the wheels to "walk" over surface irregularities, resulting in a smoother and more level ride. A cross tube connecting the two equalizing beams assures correct alignment and prevents damaging load transfer.

Short, relatively lightweight rear springs, similar to that utilized for M80 models but of 30,000 pound total capacity, support and cushion the load. The single-stage springs are 45-3/8 inches long and 4 inches wide. The installed dimension between spring centers is 34.0 inches. Eleven spring leaves combine for a total leaf thickness of 4-1/2 inches.

Hydraulically-actuated 14 X 2-1/2 (5000 pound front suspension) or 15 X 3 (7000 pound front suspension) front brakes and 15 X 4 rear brakes with vacuum power booster are standard on M60 models utilizing the regular Series 80 12-3/4 inch double-diaphragm booster. Available optionally for M60 models is the air-hydraulic brake system. Full air brakes are not available.

Manual steering systems, identical to those used for other Series 60 vehicles, are released for M60 trucks. Hydraulic power steering is available as an extra-cost option.

Base tire equipment for M60 models are 8-22.5-8PR highway-rayon-tubeless front and dual rears. Wheels are the 22.5 X 6.00 disk type. M60 tire and wheel options are the same as for other Series 60 vehicles utilizing the 15,000 pound Chevrolet rear axle.

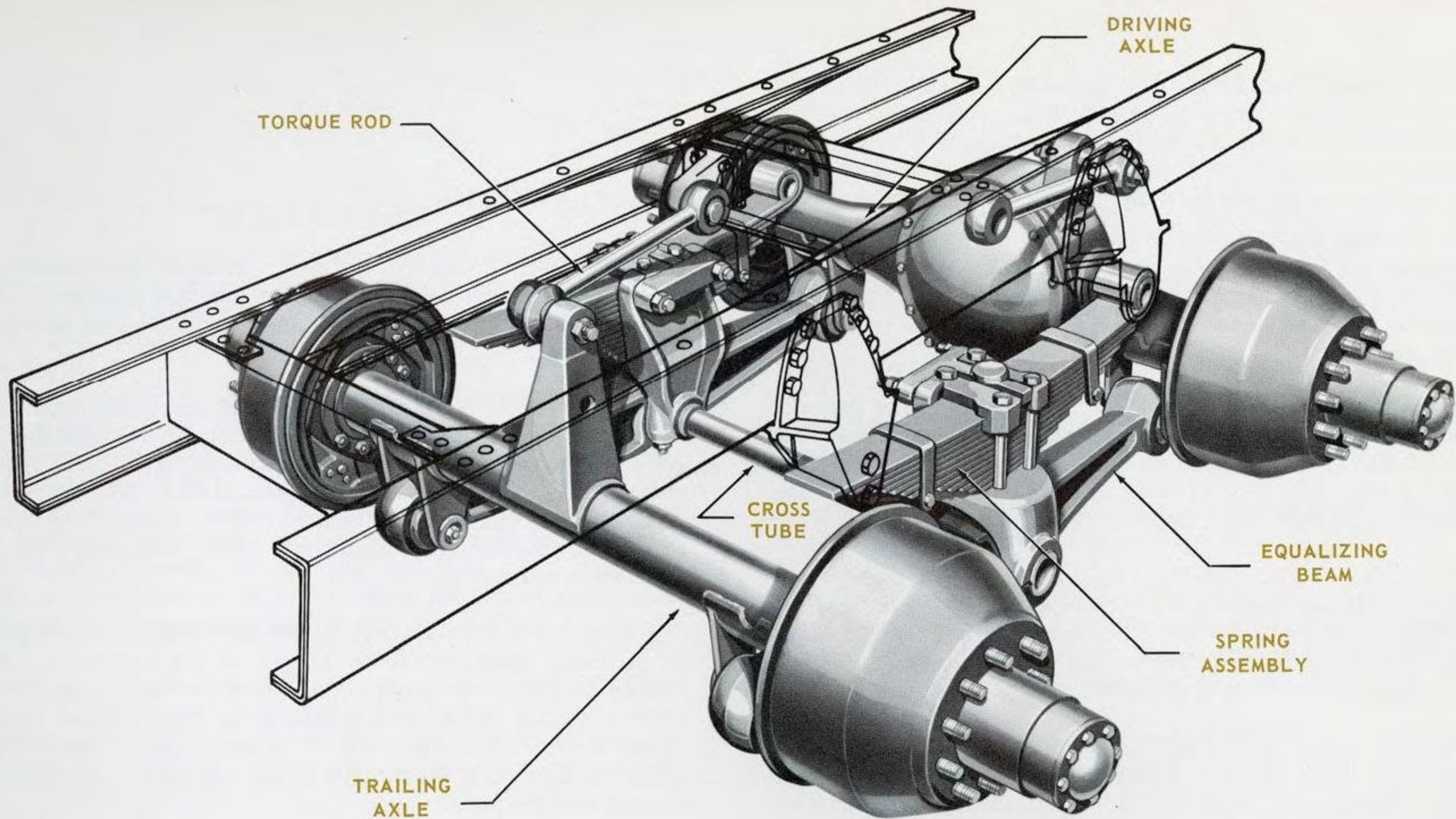

SERIES M60 REAR SUSPENSION

The stud attachment for disk wheels with the standard front suspension is 5-front and 10-rear, with an 8.75-inch bolt circle and a 11/16-inch stud diameter. A 10-stud front attachment is used when the 7000 pound front suspension is specified.

Base engine for the M60 models is the 292 L-6, with the 327 V-8 available optionally. Base transmission is the Chevrolet 4-speed. Optional 5-speed transmissions are the New Process 540C (used with 292 engine only); Clark 265V (used with 327

engine only); and Clark 267V Close-Ratio (used with 327 engine together with 2-speed rear axle). No other transmissions are available for use with M60 models, including auxiliary transmissions.

Minimum equipment for the maximum GVW rating of 30,000 pounds consists of the 7000 pound front axle and 4500 pound (each) front springs. 9-22.5-10 dual rear tires are recommended to warrant the maximum GVW.

ROOF PANEL DAMPENER. To assure against roof panel flutter, a dampener is added to the rear upper body area of all cabs except tilt models. The dampener, comprised of a rubber block, is inserted through the dome lamp opening and cemented in place in the area between the inner and outer roof panels and the cab rear panel.

FULL-VIEW REAR WINDOW. The glass used in the optional full-view rear window for conventional cabs is changed from laminated safety sheet glass to solid safety sheet glass. This change in full-view rear window material specifications also affects RPO A11, Soft Ray Glass Equipment.

WINDSHIELD WIPER BLADE, TILT MODELS. A new windshield wiper blade assembly is released for tilt-cab models, permitting replacement of the blade portion only for quick and inexpensive service. Windshield wiper blade assemblies for other truck body types already incorporate this feature.

LEVEL RIDE SEAT EQUIPMENT, RPO A55. The rear face of the Bostrum driver seat backrest is revised slightly to eliminate possible interference with the fuel tank during full rearward adjustment. The revision consists of angling forward the top portion of the backrest rear face to obtain the required clearance. Appearance of the seat is not affected except in a direct side view.

IMPROVED CORROSION RESISTANCE in the area of the hood panel and fender coach joints results from the application of heavy-bodied zinc chromate primer in addition to the regular primer. This product improvement is extended to all conventional line models except tilt-cabs and Step-Vans.

BODY

STEP-VAN BODY CHANGES. As a corrosion preventative measure, the molding formerly located mid-way between the depressed embossments at the extreme bottom of Step-Van body side panels is eliminated.

DISPATCH BOX DOOR. The dispatch box door with lock is reinstated as regular production equipment for Models R1205 and R1254, cancelling the former optional application released shortly after the start of 1963 production. When the Custom Equipment option is specified, the silver-painted door carries a silver anodized aluminum trim plate matching that of the instrument cluster.

CORVAN DOOR HINGE STOPS. Integral stops are incorporated in both the upper and lower hinges of the Corvan rear doors. The stops positively prevent the doors from contacting the body when the door checks are released, eliminating body dimpling which previously could occur. With the use of integral hinge stops, rubber bumpers are no longer required to cushion door contact with the body.

NEW LOCK STRIKERS, SEALS. Closing effort of the double side doors for Model R1205 is reduced with the release of new lock strikers for both doors and a revised door seal for the forward door. The new lock strikers, unlike the former strikers, are shorter, and thus do not extend into the seal area, thereby lessening door closing effort. Discontinued use of solid rubber at the lower rear corner of the forward door seal also helps reduce door closing effort by eliminating resistance to compression.

POWER TRAIN

NEW VACUUM SHIFT CONTROL. Improved durability, operation, and appearance are advantages of the new vacuum shift control released for all Chevrolet 15,000 pound and 17,000 pound capacity 2-speed axles except those for Series D60 models which utilize an electric shift.

The 2-piece plastic case houses a more durable speedometer adapter micro-switch, which replaces the circuit-control type switch previously used. Removal of two screws allows ready accessibility to the micro-switch control.

An improved knob design features a thumb indentation for more positive manipulation of the shift control. The speedometer adapter switch wiring and the shift cable itself are encased in a protective rubber housing for better appearance and less susceptibility to damage.

NEW REAR AXLE RATIO, SERIES C20. A new rear axle ratio of 4.11-to-1 is available optionally for manual transmission-equipped Series C20 models, resulting in improved fuel economy and longer axle life. The new ratio is restricted to use with 7-15.5-6PR or 7.00-15-6PR tires.

RADIATOR FAN diameter for Series C10, 20, 30 models with the 230 and 292 cubic inch engines is increased to 19.00 inches from 17.63 inches, providing better engine cooling at idle.

WATER PUMPS for the 348 and 409 cubic inch engines are revised to include a double by-pass for increased water flow through the engine. In connection with this change, the former 170 degree thermostat is replaced with a 180 degree thermostat.

NEW 348 ENGINE OPTION. A 2-barrel carburetor version of the 348 cubic inch displacement engine, designated the High Torque 348 Special, is released as a Regular Production Option for school bus Series S67, S67H, S69, and S69H. Except for carburetion, the new engine is identical to the existing High Torque 348 engine; horsepower and torque ratings are as follows:

	High Torque 348 Special	High Torque 348
Gross Horsepower	185 at 4000 rpm	220 at 4400 rpm
Net Horsepower	160 at 3600 rpm	180 at 4000 rpm
Gross Torque (Lb.-Ft.)	315 at 2200 rpm	325 at 2600 rpm
Net Torque (Lb.-Ft.)	285 at 1800 rpm	300 at 2400 rpm

Transmission and rear axle applicability with the new engine option is identical to that with the 327 engine.

NEW 292 ENGINE OPTION - SERIES P20, 30. Optional applicability of the 292 cubic inch displacement engine is extended to include Series P20 and P30 models. The new engine option for the above models is available for use with all transmissions.

IMPROVED EXHAUST PIPE. The 292 and 409 cubic inch engines with applicability in the CLMST 50 through 80 Series are equipped with a new exhaust pipe of increased wall thickness, thereby improving durability. Exhaust pipe wall thickness is increased from 0.067-0.081 inch (15-gauge steel) to 0.084-0.094 inch (13-gauge steel).

OPTIONAL MAIN BEARING MATERIAL. Copper-lead alloy is released as an optional material for 153, 230, and 283 engine main bearings, supplementing the use of steel-backed babbitt.

IMPROVED POWERGLIDE. New facing material is used for the Powerglide automatic transmission clutch drive plates in all Series CP10-20 applications. The new material is more durable and has better stabilization characteristics which result in improved shift quality.

POWER TRAIN-CONT.

IMPROVED 4-SPEED TRANSMISSION. Design and material changes in the Chevrolet 4-speed transmission result in improved durability and quieter operation. Bronze material is replaced by aluminum for the 2nd speed cone and by sintered iron for the 3rd speed bushing. Both aluminum and sintered iron are less susceptible to seizure as compared to bronze. In addition, a higher grade of steel is used throughout the gearset to reduce chipping and noise while increasing gear life.

Usage of a larger diameter output shaft with a greater capacity output shaft bearing; a larger shaft diameter and longer bushings for the reverse idler gear; a stronger, ribbed case in the area of the reverse idler gear; heavier rim section for the 2nd speed gear; rolled-type gearshift lever pivot pins; and a self-locking output shaft U-joint flange attaching nut all contribute to a more durable transmission. All the aforementioned design refinements are incorporated throughout the conventional line applications with the exception of light-duty models which do not have the larger output shaft and bearing feature because of the less-demanding type of operation.

NEW DELCOTRON OPTION. A new 130-ampere Delcotron generator is released as an RPO for Series S67 and S69 models. Designed for heavy-duty, high-output service, the new unit weighs 32 pounds and has a frame diameter of 6-9/16 inches. Heavy-duty ball bearings with factory-filled grease reservoirs are used.

NEW VOLTAGE REGULATOR OPTION. A new fully-transistorized voltage regulator is released as an RPO for exclusive use with the Series S67, 69 130-ampere Delcotron generator

option. The new regulator offers the advantages of no periodic servicing; constant voltage control; simplified external adjustment; and high field current for improved generator performance.

IMPROVED DELCOTRON GENERATOR MOUNTING. A new, heavier mounting bracket is released for the Delcotron generator used with the 292 cubic inch L-6 engine, preventing premature failure and providing the durability required for the 24-month or 24,000-mile truck warranty.

IMPROVED AXLE SEALING. Improved Series CKP10 rear axle differential sealing is achieved through the release of a new cover design in combination with different type retaining bolts. Overall cover configuration is unchanged with the exception of the retaining bolt hole flange area. A series of beads between the bolt holes and on the gasket side of the cover allows the latter to "dig" into the gasket at its center point.

A 0.20 inch lip curves outward (away from the differential) around the entire cover flange area outer circumference, resulting in increased durability. Screw and lock washer assembly type cover retaining bolts are replaced by a one-piece flange-head bolt for more positive torque retention. Serrations on the bolt head flange inner surface "bite" into the cover as torque is applied, thus reducing the possibility of the bolts working loose.

CLUTCH CONTROL CABLE. Lining material for the Corvair 95 clutch control cable is changed from nylon to polyethylene, reducing friction between the cable and the conduit. The new lining material not only improves clutch operation, but also extends cable assembly life.

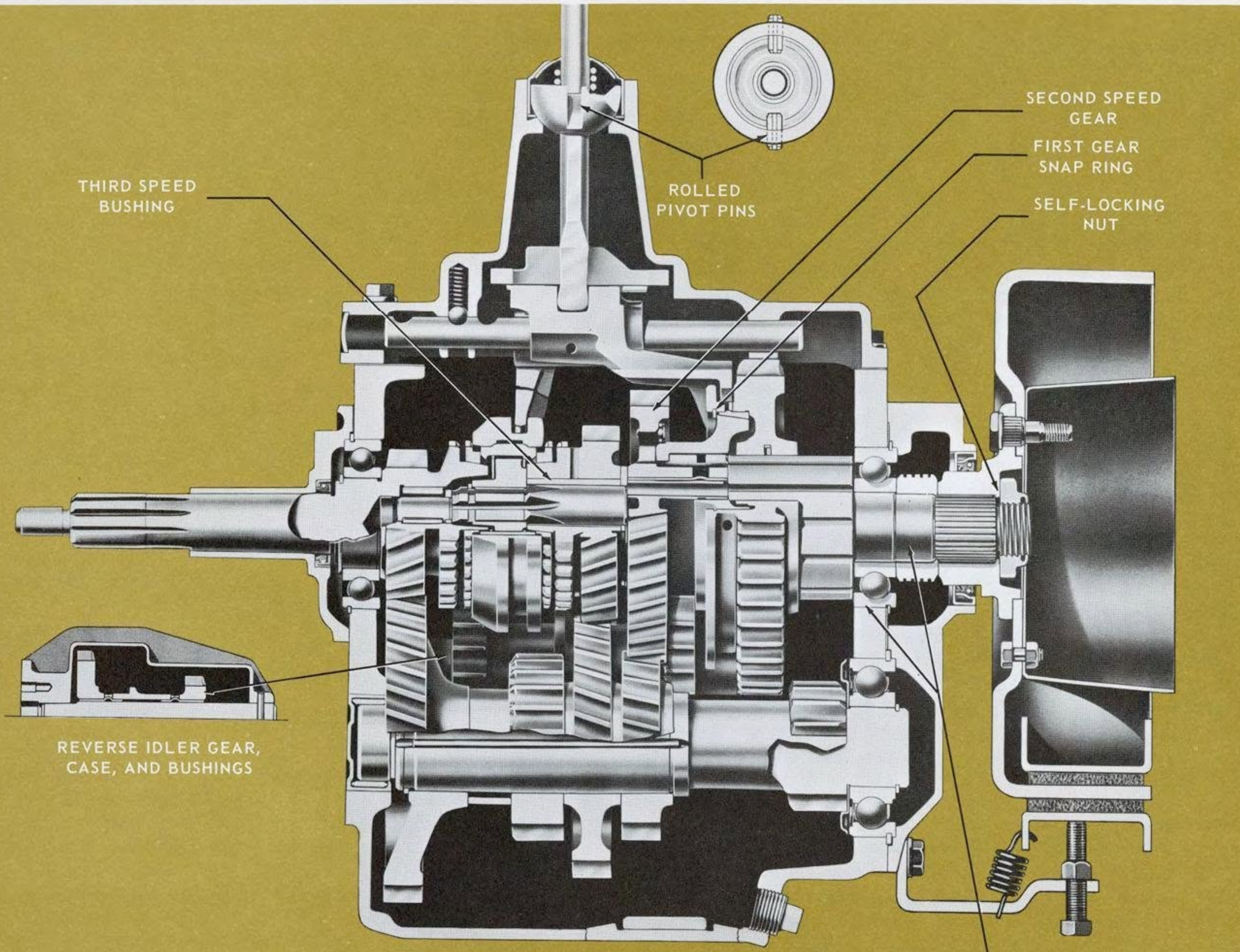

THIRD SPEED BUSHING

ROLLED PIVOT PINS

SECOND SPEED GEAR

FIRST GEAR SNAP RING

SELF-LOCKING NUT

REVERSE IDLER GEAR, CASE, AND BUSHINGS

OUTPUT SHAFT AND BEARING

IMPROVED 4-SPEED TRANSMISSION

POWER TRAIN-CONT.

NEW MANUAL TRANSMISSION CONTROL SYSTEM. A new transmission control system, which is simpler and more protected than the old system, is released for Corvair 95 models equipped with either the standard 3-speed or optional 4-speed transmission.

In the new system, the gearshift lever utilizes a housing-enclosed ball-type fulcrum which passes directly through the floor panel rather than through the seat riser. From the gearshift lever, the completely-shielded transmission control rod is routed directly through the fuel tank via a tube. The transmission control rod then attaches to the transmission shifter shaft at the rear of the vehicle.

Several distinct advantages are afforded with the new manual transmission control system: It eliminates the problem of slush and ice packing on the transmission linkage since the linkage is shielded up to and through the fuel tank; it improves cab sealing since the rubber boot on the seat riser now is eliminated; it gives more positive transmission gear shifting since the connection between the gearshift lever and control rod is more direct and simplified; and it requires less maintenance since fewer components are utilized.

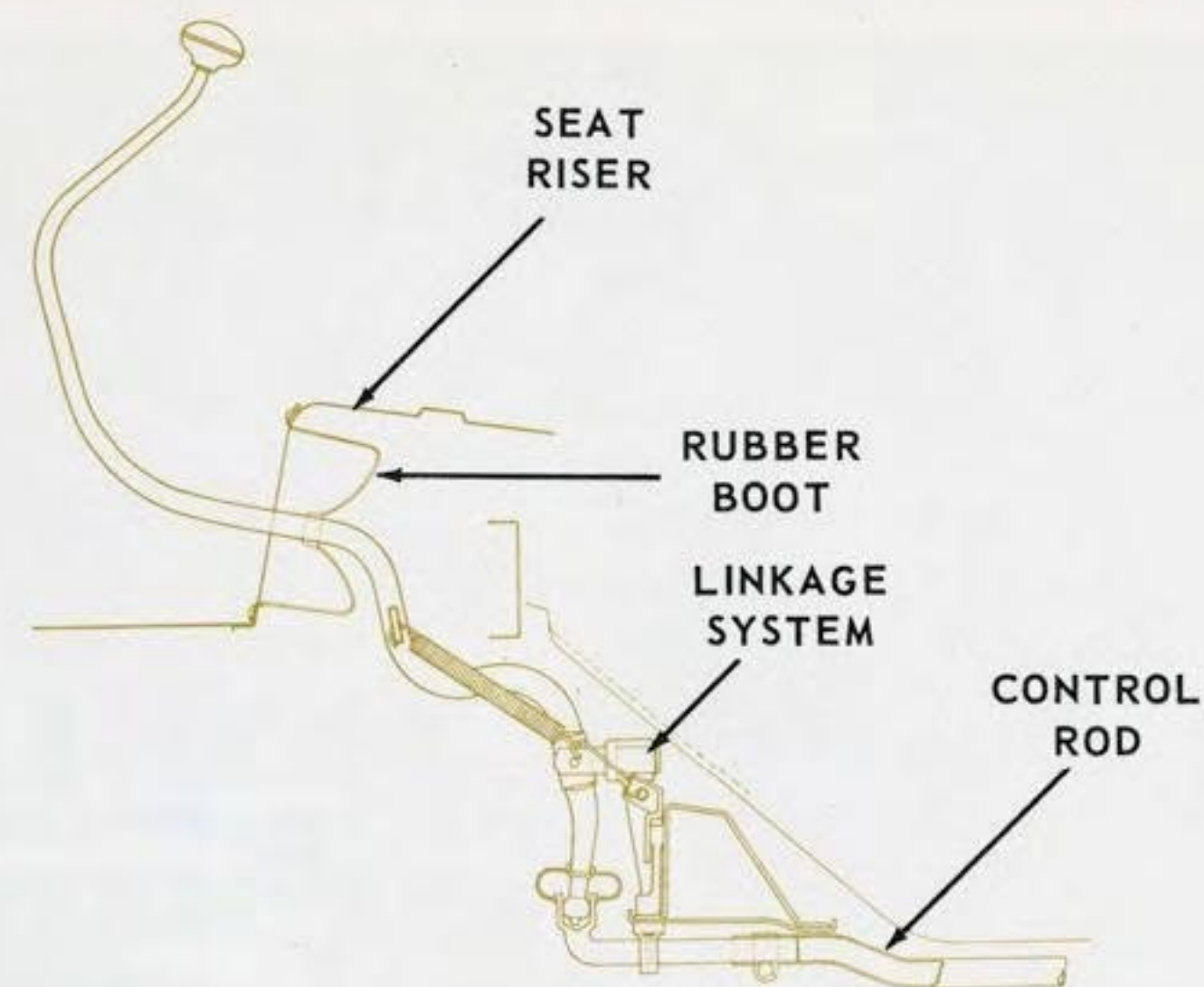

FORMER METHOD

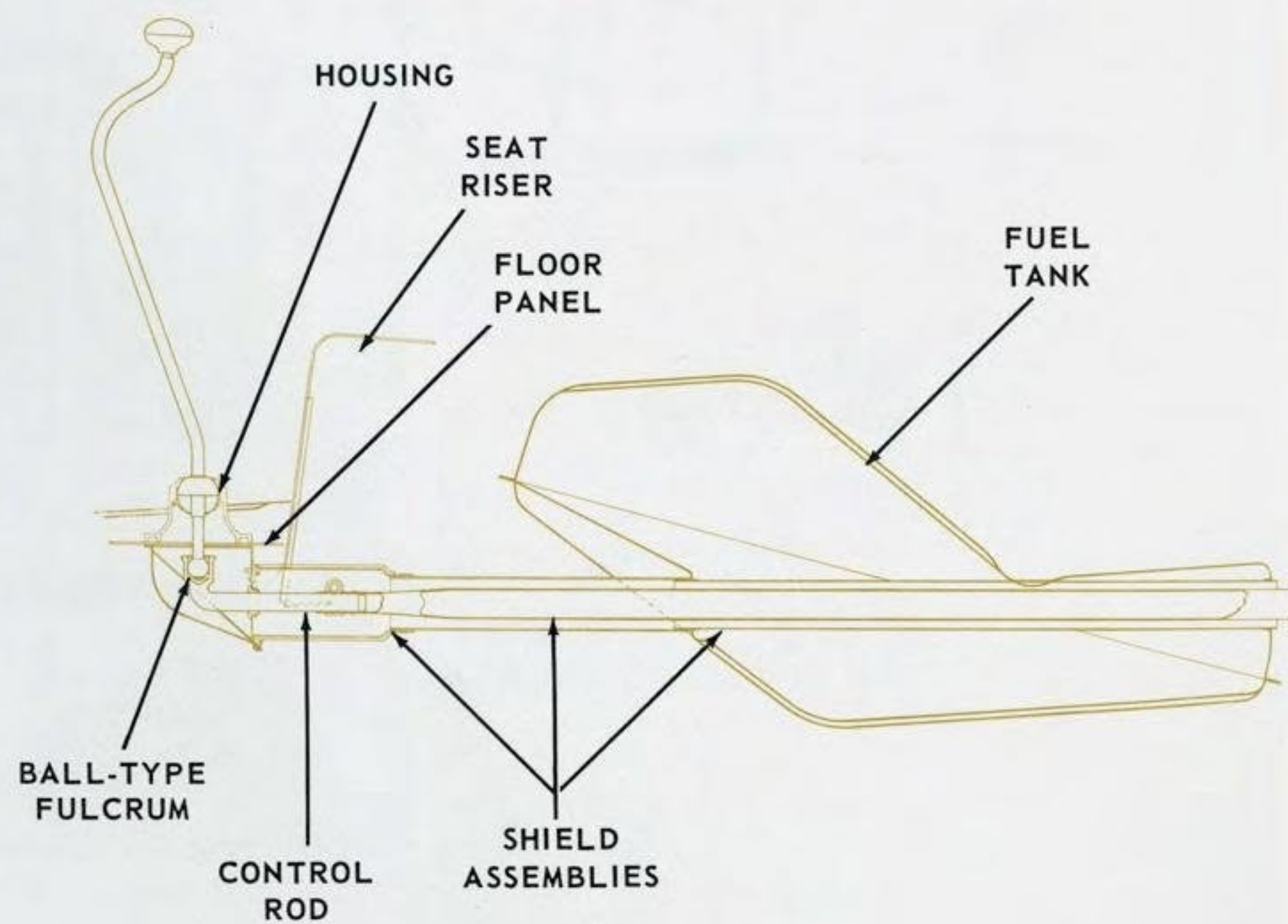

NEW METHOD

CHASSIS

EMERGENCY AIR BRAKE EQUIPMENT (RPO J75), released for models with full-air brakes, is cancelled. Designed in compliance with the California Brake Law, RPO J75 is made obsolete because of revisions to the law. A new design is planned for interim 1964 release.

IMPROVED BRAKE ASSEMBLIES. Front and rear brake assemblies for Series CP10 trucks and rear brake assemblies for Series K10 vehicles are made more durable through the use of larger brake shoe anchor pins and primary and secondary brake shoe reinforcements.

EXTENDED AIR BRAKE AVAILABILITY. Full air brake equipment is released as a Regular Production Option for Series S67H and S69H models. Formerly, only hydraulic with power assist or air-hydraulic brakes were obtainable with these models.

NEW BRAKE EQUIPMENT OPTION. RPO Z72, a new brake equipment option which includes a vacuum reserve tank, a vacuum gauge, and a low vacuum indicator light, is released for "hydraulic with vacuum booster" - equipped M60 and M80 trucks. The new option, designated as Vacuum Reserve Tank, Gauge, and Warning Light Equipment, is designed to comply with Interstate Commerce Commission regulations pertaining to tandem vehicles engaged in interstate operation.

Options J80, Vacuum Power Brake Reserve Tank, and J81, Vacuum Gauge, still may be obtained independently of RPO Z72 for the M60 and M80 vehicles.

NEW AIR COMPRESSOR APPLICABILITY. The Tu-Flo 500 water-cooled air compressor, formerly available with air-hydraulic or full-air brake-equipped diesel models only, is now required for use with CM80 models having RPO V04, Radiator Shutter Equipment. These models, however, will continue to use the air-cooled type compressor with the hydraulic or full-air brake equipment when radiator shutters are not specified.

Cooling efficiency of an "air-cooled" type compressor is reduced to an unsatisfactory level when the radiator shutters are in a closed position because of the restricted flow of incoming air. The use of a water-cooled compressor for this type of application results in better cooling with longer life.

NEW NYLON CORD TIRES. Nylon material replaces rayon for all 6.70-15-4PR and 6.50-16-4PR "on-off road" tubeless tires released for Series CKP10 models, thus substituting RPO R38 for RPO R28 and RPO R69 for RPO R62. Nylon is less susceptible to the sudden shock loads more often encountered in off-the-road type operation.

FRAME GAUGE INCREASES. When RPO G60 auxiliary springs are used on Series C10 models, the fourth crossmember brace metal gauge thickness is increased from 0.144 inches to 0.205 inches to improve frame durability.

Additionally, the metal gauge thickness of the Number 3 frame crossmember and brace on Series M80 models with auxiliary transmissions (RPO's M64 and M70) is increased from 0.189 inches to 0.228 inches to provide greater frame strength.

NEW WHEEL OFFSET. Wheel offset is increased from 4.75 inches to 5.00 inches for light-duty models equipped with optional 7.00-16-6PR (RPO R66) or 7.50-16-8PR (RPO R68) dual rear tires. The larger offset, increasing tire clearance by a total factor of 0.50 inches, eliminates the possibility of sidewall interference with subsequent rubbing.

JOUNCE BUMPER MATERIAL IMPROVEMENT. On Series CP 10-20-30 models, the lower control arm jounce bumper rubber compound is improved to better withstand cracking caused by extreme cold conditions. Jounce bumper rubber fillers and elastic fibers are revised to provide a more pliable bumper that remains elastic under extreme weather conditions.

NEW PANEL MODEL REAR SPRING. A single-stage rear coil spring, similar to the 1962 C10 heavy-duty design, is now standard equipment on 1/2-ton panel models. The new spring replaces the 2-stage configuration used formerly, and is intended to provide quieter ride characteristics. Previously, at curb weight, the panel model spring was close enough to the second stage that suspension jounce due to road irregularities caused a certain amount of spring slap as the spring alternated between the first and second stages. Because the panel model body loads are greater than any other model loads in the same series, the new spring is designed to accommodate the additional weight.

CHASSIS-CONT.

REAR SPRING OPTIONS REVISED. When RPO Z57 (23,000 Pound GVW Heavy-Duty Equipment) is called for on C-L-T60 models, RPO G56 (20,800 Pound Rear Springs) must be used except when RPO G58 (23,000 Pound Rear Springs) or RPO G60 (Auxiliary Springs) are specified.

Additionally, the 17,000 pound rear axle is no longer mandatory equipment when RPO G56 is used on C-D-L-S-T60 models. RPO G56 now may be specified for use with the 15,000 pound rear axle. This revision provides 20,800 and 23,000 pound springs of 3-inch width as free options on 60 Series trucks.

NEW POWER STEERING PUMP. The hydraulic steering gear assembly, standard on M80 models and optional (RPO N40) on the remaining 60 and 80 Series trucks, is revised to include a higher flow rate pump on models with RPO F68.

A larger pump orifice enables more hydraulic fluid to enter the cylinder when quick steering requires a faster fluid-to-cylinder flow rate. The larger pump eliminates the possibility of the heavy-duty models reverting to manual steering on cornering or other rapid steering applications.

NEW FRONT SPRING EYE AND BUSHING. A Berlin-type spring eye design for 3500, 4500, 5500, and 7000 pound capacity front springs replaces the overhung-type eye previously used in these applications. Designed to eliminate unwrapping at the spring eye, the Berlin-type eye increases spring leaf expansion capacity and improves overall spring durability. The rigid configuration of the new eye accommodates greater brake loads by more efficiently distributing the lateral spring deflection forces. The resultant reduced stress at the spring eye eliminates the need for a weld from the end of the first leaf to the second leaf, as illustrated below on the overhung-type eye formerly used.

In addition, solid-pin, rubber-mounted spring eyes replace the drilled eye bolt, steel-backed bronze bushings used previously on Series 80 truck 5500 and 7000 pound front springs. The new bushing, a version of the base 3500 pound spring rubber bushing, not only better withstands heavy-duty loads, but also needs no periodic lubrication. With the addition of the new bushing for 5500 and 7000 pound front springs, all 3-inch wide medium and heavy-duty truck springs are equipped with rubber-mounted spring eye bushings.

NEW LIGHT-DUTY TIRES. Passenger-type, 6.70-15-4PR and 7.10-15-4PR tubeless tires of 2-ply construction in combination with 15 X 5.50K wheel assemblies replace similar size 4-ply constructed tires used with 15 X 5K wheels as base and optional equipment for Series CKP 10 trucks. Utilization of the 2-ply tire construction increases interchangeability, while maintaining satisfactory durability.

CANCELLED TIRE OPTIONS. 7.00-16-6 PR (RPO R66) and 7.50-16-8 PR (RPO R68) highway, rayon, tube-type tires, formerly available as optional equipment for P30 models, are cancelled for 1963.

IMPROVED TRIM HEIGHT FOR CORVANS. A longer rear coil spring is released as standard equipment on Corvaire 95 panel trucks. The increased length of the rear spring improves Corvan trim height at normal load from 7.42 inches at 1920 pounds to 7.92 inches at 1920 pounds.

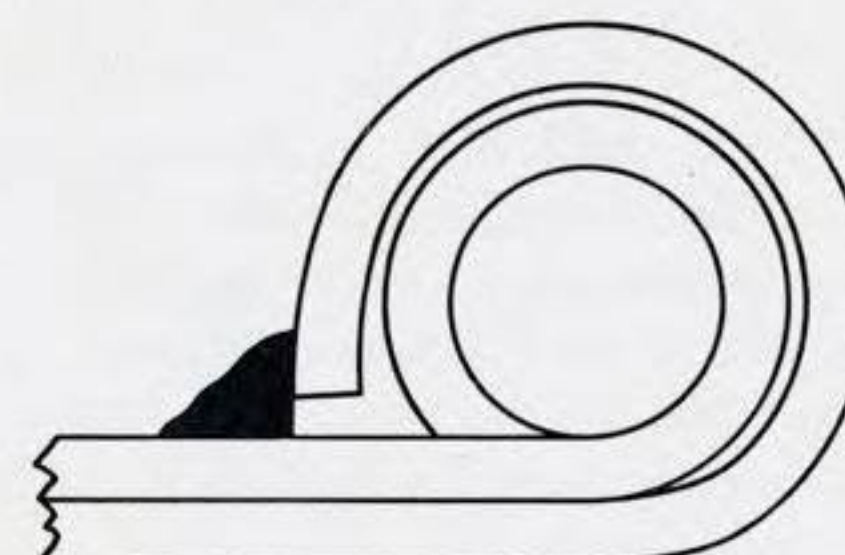

OVERHUNG-TYPE SPRING EYE

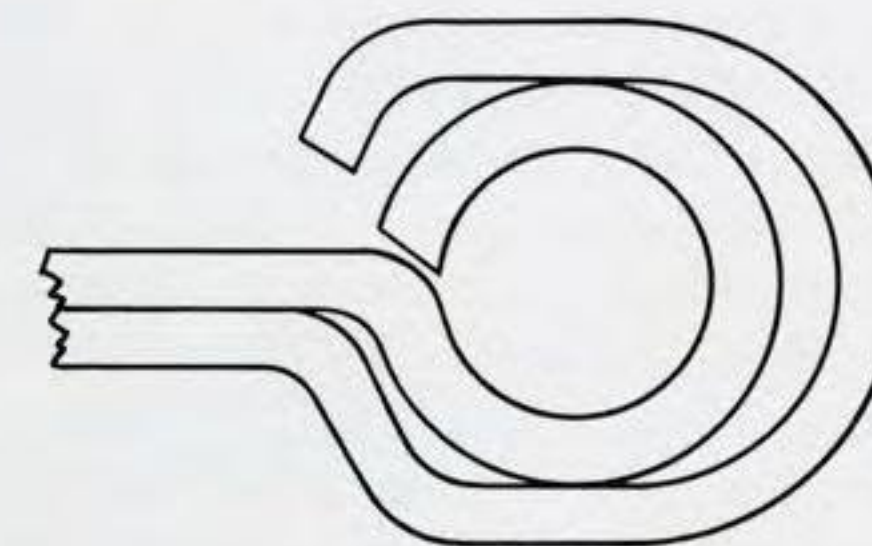

BERLIN-TYPE SPRING EYE

TRANSMISSION LINE-UP

TRANSMISSION	STANDARD APPLICABILITY	OPTIONAL APPLICABILITY
3-Speed	CKPR10; CKP20, 53-5580, 54-5680	None
3-Speed (wide ratio)	None	CP10, 20, 30
4-Speed	CP30, CLS50, CLMST60, 60H	CKPR10, CKP20, 54-5680
5-Speed New Process 540C	None	CLMST60-60H (w/292 L-6)
5-Speed Clark 265 V	None	CLMST60-60H (w/327 or 348 V8)
5-Speed Clark 267 V	D60H	CLMST60-60H (w/327 or 348 V8)
5-Speed Clark 264 VO	D60	None
5-Speed Spicer 3152	CLMT80 (w/348 V8)	CLS60-60H (w/327 or 348 V8)
5-Speed Spicer 3152A	None	D60H; CLS60-60H (w/V8); CLT80 (w/348 V8)
5-Speed Spicer 3153	None	D60
5-Speed Spicer 5652B	W80	CLMT80 (w/409 V8)
5-Speed Spicer 5756B	EU80	CLT80 (w/409 V8)
8-Speed Fuller R46	None	EU80; CLMT80 (w/409 V8)
2-Speed Powerglide	None	CPR10; CP20; 53-5580; 54-5680
6-Speed Powermatic MT30	None	CS60, 60H; CMT80 (w/348 V8)
6-Speed Powermatic MT40	None	CM80 (w/409 V8); EUW 80
3-Speed w/Overdrive	None	53-5580, 54-5680
2-Speed Transfer Case T221	K10, 20	None
3-Speed Aux. Spicer 5831G	None	M80 (w/348 V8)
4-Speed Aux. Spicer 6041	None	M80
4-Speed Aux. Spicer 7041	None	W80

APPENDIX

ENGINE LINE-UP

ENGINE	SERIES APPLICATION	COMP RATIO	GROSS HORSE-POWER	GROSS TORQUE	NET HORSE-POWER	NET TORQUE	CLUTCH SIZE (In.) & TYPE
153 L-4	Std: P10 Opt: None	8.50	90 @ 4000	152 @ 2400	82 @ 4000	144 @ 2000	10-D
164 HO-6	Std: R10 Opt: None	8.25	95 @ 3600	154 @ 2400	78 @ 3600	140 @ 2400	9-1/8-D
164 HO-6 Spec. Cam	Std: None Opt: R10	9.25	110 @ 4400	160 @ 2600	90 @ 4000	145 @ 2400	9-1/8-D
194 L-6	Std: 5380, 5580 Opt: None	8.50	120 @ 4400	177 @ 2400	95 @ 4000	155 @ 2000	9-1/8-D
230 L-6	Std: CK10,20; C30; P20-30; CLS50 Opt: P10	8.50	140 @ 4400	220 @ 1600	120 @ 3600	205 @ 1600	10-D (CK10,20) 11-D (Others)
230 L-6	Std: None Opt: 5380, 5580	8.50	155 @ 4400	215 @ 2000	Not Rated	Not Rated	9-1/8-D
230 L-6 Economy Carb.	Std: None Opt: C10	8.50	125 @ 3400	210 @ 1600	100 @ 3200	200 @ 1200	10-D (Std.) 11-D (Opt.)
292 L-6	Std: CMLT60; CLT60H S62,64,67 Opt: CK10,20; C30; CLS50; P20,30	8.00	170 @ 4000	275 @ 1600	153 @ 3600	255 @ 2000	12-C (Std. models & CLS50) 11-D (Others)
283 V-8 2-bbl	Std: 5480, 5680 Opt: None	9.25	195 @ 4800	285 @ 2400	150 @ 4400	245 @ 2400	10-D (3-Speed) 10-13/32-D (4-Speed)

D - Diaphragm spring.

C - Coil spring.

ENGINE LINE-UP - CONT.

ENGINE	SERIES APPLICATION	COMP RATIO	GROSS HORSE-POWER	GROSS TORQUE	NET HORSE-POWER	NET TORQUE	CLUTCH SIZE (In.) & TYPE
283 V-8 2-bbl	Std: None Opt: CK10,20; C30; CL50	9.0 (*)	175 @ 4400	275 @ 2400	145 @ 4200	245 @ 2000	11-D
283 V-8 4-bbl	Std: None Opt: 5480, 5680	9.25	220 @ 4800	295 @ 3200	Not Rated	Not Rated	10-D (3-Speed) 10-13/32-D (4-Speed)
327 V-8	Std: S69,69H Opt: CLT60,60H;S62 64,67,67H;M60	8.0	185 @ 4400	305 @ 2000	158 @ 4000	280 @ 2000	13
348 V-8 2-bbl	Std: None Opt: CLMT60,60H; S62,64,67,67H S69,69H;M60	7.75	185 @ 4400	315 @ 2200	160 @ 3600	285 @ 1800	13
348 V-8 4-bbl	Std: CLMT80 Opt: None	7.75	220 @ 4400	325 @ 2600	180 @ 4000	300 @ 2400	13
409 V-8	Std: None Opt: CLMT80	7.75	252 @ 4000	390 @ 2400	215 @ 4000	352 @ 2400	12-C (2-plate)
4-53 Diesel	Std: D60,60H Opt: None	17.0	130 @ 2800	271 @ 1500	118 @ 2800	263 @ 1500	13-C
6V-53 Diesel	Std: EUW80 Opt: None	17.0	195 @ 2800	423 @ 1500	183 @ 2800	415 @ 1500	14-C

D - Diaphragm spring,
C - Coil spring,

* - 8.5 for Series 50 applications.

APPENDIX

SINGLE-SPEED AXLE LINE-UP

CAPACITY (Lbs.)	RATIO	TYPE	STD. USAGE	OPT. USAGE
2500	3.55	Hypoid	R10	None
2700	3.36	Hypoid	53-5580	54-5680
2700	3.08	Hypoid	54-5680	None
2700	3.70	Hypoid	None	53-54-55-5680
3300	3.73	Hypoid	K10	None
3500	3.73	Hypoid	C10	P10
3500	4.11	Hypoid	P10	C10
3500	3.07	Hypoid	None	C10
5200	4.57	Hypoid	CKP20	None
5200	4.11	Hypoid	None	C20
7200	5.14	Hypoid	CP30	None
11,000	6.17	Hypoid	CLS50	None
15,000	7.20	Hypoid	CLST60	CLS50
15,000	6.17	Hypoid	D60	None
17,000	7.20	Hypoid	CLST60H	CLT60; S67,69
18,500	7.17	Spiral Bevel	CLT80	None
18,500	5.57	Spiral Bevel	None	EU80
23,000	6.67	Spiral Bevel	None	CLT80
23,000	5.43	Spiral Bevel	None	EU80
28,000 (bogie)	7.20	Hypoid	M60	None
30,000 (bogie)	7.17	Spiral Bevel	M80	None
30,000 (bogie)	5.57	Spiral Bevel	W80	None
34,000 (bogie)	7.17	Spiral Bevel	None	M80
34,000 (bogie)	6.50	Spiral Bevel	None	W80

TWO-SPEED AXLE LINE-UP

CAPACITY (Lbs.)	RATIO	TYPE	STD. USAGE	OPT. USAGE
15,000	5.83/7.95	Hypoid	None	D60
15,000	6.40/8.72	Hypoid	None	CLS50,60; T60
17,000	6.40/8.72	Hypoid	None	CLT60,60H; S67,69; S67,69H
17,000	7.17/9.97	Spiral Bevel	None	CLT60,60H
17,000	4.87/6.77	Spiral Bevel	D60H	None
18,500	6.50/8.87	Spiral Bevel	None	CLT80
18,500	7.17/9.77	Spiral Bevel	None	CLT80
18,500	5.57/7.60	Spiral Bevel	EU80	None
18,500	4.87/6.65	Spiral Bevel	None	EU80
23,000	6.71/9.14	Spiral Bevel	None	CLT80
23,000	5.43/7.39	Spiral Bevel	None	EU80
28,000 (bogie)	6.40/8.72	Hypoid	None	M60

LIMITED-SLIP AXLE LINE-UP

CAPACITY (Lbs.)	RATIO	TYPE	STD. USAGE	OPT. USAGE
2500 (Positraction)	3.55	Hypoid	None	R10
2700 (Positraction)	3.36	Hypoid	None	53-54-55-5680
2700 (Positraction)	3.08	Hypoid	None	54-5680
2700 (Positraction)	3.70	Hypoid	None	53-54-55-5680
3500 (Positraction)	3.73	Hypoid	None	CP10
5200 (NoSPIN)	4.57	Hypoid	None	CP20
7200 (NoSPIN)	5.14	Hypoid	None	CP30

APPENDIX

MODEL LINE-UP

VEHICLE TYPE	LIGHT-DUTY				MEDIUM-DUTY				HEAVY-DUTY		TOTAL
	1/2-TON	3/4-TON	3/4-TON SPECIAL	1-TON	1-1/2 TON	1-1/2 TON SPECIAL	2-TON	2-TON HEAVY-DUTY	2-1/2 TON		
El Camino Pickup	53-5480 55-5680										2
Corvair 95 Panel & Pickup	R1254 (Rampside) R1205 (Corvan)										2
Stepside Pickup	C1404 C1504 K1404 K1504	C2504 K2504	C3604S	C3604							8
Cowl	C1402	C2502	C3602S	C3602	C5102 C5202 C5302 C5502	C6102S C6302S C6502S	C6102 C6302 C6502	C6102H C6302H C6502H			17
Windshield Cowl	C1412	C2512	C3612S	C3612	C5112 C5212 C5312 C5512	C6112S C6312S C6512S	C6112 C6312 C6512	C6112H C6312H C6512H			17
LCF Cab-Chassis					L5203 L5303 L5603	L6203S L6303S L6503S L6603S L6903S	L6203 L6303 L6503 L6603 L6903	L6203H L6303H L6503H L6603H L6903H	E8203 E8303 L8203 L8303 L8603		23
Tilt-Cab Chassis						T6203S T6303S T6603S T6803S T6903S	T6203 T6303 T6603 T6803 T6903	T6203H T6303H T6603H T6803H T6903H	U8203 U8303 T8203	T8303 T8603 T8803	21
Conventional Cab-Chassis	C1403 C1503 K1403 K1503	C2503 K2503	C3603S C3803S	C3603 C3803	C5103 C5203 C5303 C5503	C6103S D6103S C6203S D6203S C6303S D6303S C6503S D6503S C6803S D6803S	C6103 D6103 C6203 D6203 C6303 D6303 C6503 D6503 C6803 D6803	C6103H D6103H C6203H D6203H C6303H D6303H C6503H D6503H C6803H D6803H	C8103 C8203 C8303 C8503 C8803		49

MODEL LINE-UP - CONT.

VEHICLE TYPE	LIGHT-DUTY				MEDIUM-DUTY			HEAVY-DUTY		TOTAL
	1/2-TON	3/4-TON	3/4-TON SPECIAL	1-TON	1-1/2 TON	1-1/2 TON SPECIAL	2-TON	2-TON HEAVY-DUTY	2-1/2 TON	
Fleetside Pickup	C1434 C1534 K1434 K1534	C2534 K2534								6
Panel	C1405 K1405		C3605S	C3605						4
Suburban Carryall	C1406 K1406 C1416 K1416									4
Conventional Stake		C2509	C3609S	C3609	C5109 C5309					5
LCF Stake					L5309					1
Tandem							M6303 M6503 M6803		W8303 M8303 W8503 M8503 W8803 M8803	9
School Bus					S5302		S6202 S6402 S6702 S6902	S6702H S6902H		7
Forward Control	P1342	P2342 P2542 P2642		P3342 P3542 P3642						7
Step-Van	P1345	P2345 P2545 P2645 P2535 P2635		P3345 P3545 P3645 P3535 P3635						11
Grand Total	26	17	7	15	19	26	33	28	22	193
		65				78		50		

INDEX

A

Absorbers, shock	69,89
Access door, engine	41,48,49
Air cleaner	58,62
Air conditioning	53
Air shut-off door	41,49
APPENDIX	99-105
Axle seals	94

B

Blower, engine	61
BODY	37-49
BODY, EL CAMINO	82,83
BODY EQUIPMENT	50-55
Body insulation	38
Body mounts	39
Brake, parking	69
Brakes	69,73,97
Brakes, self-adjusting	69,73
Brakes, Stopmaster	69,73
Bumper, rear step	54

CD

Camshaft, high-lift	58,60
Caps, hub	18,22
CHANGES, INTERIM 1963	90-98
CHASSIS	67-73
CHASSIS, EL CAMINO	86-89
Clutch	58,60,94
Colors, exterior	18
Control knobs	34
Custom cab trim plate	18,25
Custom equipment charts	55
Delcotron generator	62
Dispatch box door	35,92
Door hinge stops	92
Door opening	38,42,43
Door panel, inner	26,27
Driveline	62,63

E

EL CAMINO, THE	75-89
Electrical systems	70,94
Engine:	
164	58,59
230	62
283	60,62
292	60,62,93
327	60,61
348	61,93
Engine access door	41,48,49
Engine blower	61
Engine line-up chart	100,101
Engine performance, Corvair 95	60
Equipment, Custom	55
Exhaust system	60,61,93
Exterior colors	18
EXTERIOR STYLING	18-25

F

Fan, radiator	93
Filter, fuel	61
Filter, oil	61
FOREWORD	2
Frames	97
Front suspension	68,70,71,97,98
Fuel filter	61
Fuel tank	39,61

GH

Generator, Corvair 95	58
Generator, Delcotron	62
Grilles, radiator	18,20,21
Gross vehicle weight	10
Hangers, spring	68,72
Harness, wiring	70
Heaters	50,51
Hinge pillar	38,42,43
Hub caps	18,22

IKL

Inner door panel	26,27
Instrument panel	26,32,33-35
Insulation, body	38
INTERIM 1963 CHANGES	90-98
Interior, Custom	30,31
Interior, regular production	28,29
INTERIOR STYLING	26-35
Interior ventilation	39
Knobs, control	34
LCF diesel tandems	10,14
Lock pillar	39,45
Locks	39,44,92
Lubrication intervals	68,70,71

MOP

MODEL LINE-UP	9-15
Model line-up chart	104,105
Mounts, body	39
Oil filter	61
Opening, door	38,42,43
Panel, instrument	26,32,33-35
Parking brake	69
Pillar, hinge	38,42,43
Pillar, lock	39,45
Plates, series	18,24
POWER TRAIN	57-65
POWER TRAIN, EL CAMINO	84,85
Pump, water	60,61,93

R

Radiator	62
Radiator fan	93
Radiator grilles	18,20,21
Rear axle line-up charts	102,103
Rear axles	63,64,65
Rear step-bumper	54
Rear suspension	69,97,98
Roof panel dampener	92

S

Seals, axle	94
Seat construction	38,39,46,47,92
Seat trim	26
Self-adjusting brakes	69,73
Series plates	18,24
Shield, underbody splash	41,49
Shift control, vacuum	93
Shock absorbers	69,89
Splash shield, underbody	41,49
Spring hangers	68,72
Starting motor	62
Steering	68,71
Steering, power	98
Step-Van models	10,12,39-41,92
Stopmaster brakes	69,73
Stops, door hinge	92
STYLING	17-35
STYLING, EL CAMINO	76-81
Suspension, front	68,70,71,97,98
Suspension, rear	69,97,98

TVW

Tandems, LCF diesel	10,14
Tandems, trailing axle	10,90,91
Tank, fuel	39,61
Tires	69,70,97,98
Trailing axle tandems	10,90,91
Transmission line-up chart	99
Transmissions	62,93-96
Transmission tunnel	39
Trim plate, Custom cab	18,25
TRUCK, THE 1964 CHEVROLET	5-7
Vacuum shift control	93
Ventilation, interior	39
Water pump	60,61,93
Weight, gross vehicle	10
Wheels	69,70
Wheel trim disk	23
Wiring harness	70

Chevrolet Motor Division of General Motors Corporation reserves the right to make changes at any time, without notice, in prices, colors, materials, equipment, specifications, and models, and also to discontinue models.

