

Just for fun . . .
**DRIVE THE RACE-PROVED
ROAD CARS**



'68 Shelby
COBRA GT 350 / 500

For 1968 . . . Carroll Shelby presents four brand-new fun cars

Get behind the wheel of a Shelby Cobra GT and you command a new motoring dimension.

Carroll Shelby has worked a bit of racing car magic on the Ford Mustang.

Result? The Shelby Cobra GT . . . a true road performer that rivals Europe's finest limited-production cars

—but for thousands of dollars less.

That's not all the news.

Now you can own a Cobra GT 350 or GT 500 convertible!

Same great features as the famed GT 350 and GT 500 fastback 2+2 coupes. If

you love driving, you'll appreciate the pleasure of Cobra's thrilling GT performance and exclusive styling. It's a pleasure you can afford, as your Shelby Cobra dealer will gladly prove.





SPECIFICATIONS

ENGINE SPECIFICATIONS: GT 500

Standard: All new Cobra OHV 428 cu. in. V-8; 360 horsepower @ 5400 rpm; 420 lbs./foot of torque @ 3200 rpm; 4.13" x 3.984" bore and stroke; compression ratio 10.5:1; hydraulic valve lifters. Cobra high velocity high volume intake manifold with advanced design, 4 bbl Holley carburetor with 600 CFM (flow rate) primaries, 715 CFM secondaries. High capacity fuel pump.

Optional*: All new Cobra hydraulic OHV 427 cu. in. V-8; 400 horsepower @ 5600 rpm; 460 lbs./foot of torque @ 3200 rpm; 4.235" x 3.788" bore and stroke; compression ratio 11.6:1; hydraulic valve lifters, advanced design cathedral float 4 bbl Holley carburetor. High capacity fuel pump.**

GT 350

Standard: All new OHV 302 cu. in. V-8; 250 horsepower @ 4800 rpm; 310 lbs./foot of torque @ 2800 rpm; 4.0" x 3.0" bore and stroke; compression ratio 10.5:1; hydraulic valve lifters. Cobra high velocity high volume intake manifold with 4 bbl carburetor with 600 CFM flow rate.

Optional*: Cobra centrifugal supercharger, 335 horsepower @ 5200 rpm; 325 lbs./foot of torque @ 3200 rpm.†

NOTE: All Cobra GT engines include high velocity high flow intake manifolds, die-cast aluminum rocker covers, low restriction oval design diecast aluminum air cleaner, chromed filler caps, high capacity fuel pumps.

GENERAL SPECIFICATIONS:

Body types: 2-door fastback and convertible. Full unitized construction.

Wheelbase: 108.0"
Tread: Front, 58.1"; Rear, 58.1"
Length: 186.81"
Width: 70.9"
Height: Fastback, 51.8"

††Curb weight: 350 (302 engine, autom. transm.); fastback 3146 lbs.
500 (428 engine, autom. transm.); fastback, 3445 lbs.

††Weight distribution: 350: 53% F, 47% R.
(Fastback) 500: 56.4% F, 43.6% R.

††Estimated design weights

Suspension

Front: Independent with coil springs and ball joints. Spring rates; 320 lbs./in. (350), 360 lbs./in. (500). Front stabilizer bar, .94" diameter. Extra capacity telescopic double acting tubular adjustable shock absorbers. Rear: 4-leaf semi-elliptic springs with extra capacity telescopic double acting tubular adjustable shock absorbers and custom windup dampers. Rate: 135 lbs./in. (350 and 500).

Steering: Recirculating ball and nut with hydraulic power assist. Steering ratio 16:1; 37.16' turning circle.

Brakes: Front, floating caliper power assisted ventilated 11.3" discs with high performance pads; rear drums 10" x 1.75" size with high performance linings. Dual master cylinder with low pressure warning light. Effective lining area: 180.0 sq. in.

Wheels: 15" safety type steel wheel, 6" rim width with diecast cover standard.

Tires: 15" Goodyear Speedway 350 E70 true 4 ply, nylon, wide path tires are designed for this car, 130 mph test standard.

Transmission: Fully synchronized four-speed manual standard.

Ratios: First—2.32:1
Second—1.69:1
Third—1.29:1
Top—1.00:1
Reverse—2.32:1

Heavy-duty, close-coupled, automatic transmission optional. Shift handle detent minimizes skipping or missed shifts when hand-selecting gears.

Ratios: First—2.46:1
Second—1.46:1
Top—1.00:1
Reverse—2.20:1

Final drive: Heavy-duty rear axle with straddle-mounted large diameter ring gear and deep offset drive pinion. Standard ratios:

500—Manual transmission 3.50:1
Automatic transmission 3.50:1
350—Manual transmission 3.89:1
Automatic transmission 3.50:1

Safety Features: Padded instrument panel, sun visors, steering wheel center, sun visors. Impact-absorbing collapsible steering column. Seat back retaining latches, padded front seat backs, safety door and regulator handles. Seat belts front and rear. Advanced design front seat shoulder harnesses with improved inertia reels (dual style in fastback, diagonal style in convertible). Padded high-strength steel 1½"

diameter integral overhead safety bar. Sequential turn signals, front safety marker lights, rear quarter marker reflectors.

Styling, Appointments

Exterior: Precision moulded custom fiberglass hood and front assembly incorporates dual air intake scoops, functional louvered extractors. Custom self retained push-and-turn hood locks with additional retaining cables. Rectangular fog lights mounted in grille opening. Rolled section lightweight moldings on grille and wheel openings. Le Mans type air extractors on rear quarters of roof (fastback only). Brake air scoops set in lower rear quarters. Precision moulded custom fiberglass trunk deck lid with integral air spoiler. GT stripe on lower rocker panels.

Interior: Deluxe all-vinyl interior with bucket seats, full loop pile carpeting, matching custom styled console with padded armrest glove box with rear ash tray and courtesy light, walnut-grained appliques on instrument panel and door panels. Full instrumentation; 8000 rpm tachometer, 140 mph speedometer, oil pressure, ammeter, water temperature, fuel gauge, electric clock (supercharger pressure and fuel pressure if supercharged). Folding rear seat* with retractable safety luggage retaining bar (fastback only), tie-down loops on safety bar (convertible only).

These specifications were in effect at the time of printing. In the interest of constant product improvement, Shelby Automotive, Inc. reserves the right to add, alter or delete equipment or options, or to change specifications at any time without notice and without incurring obligation.

*Extra-cost option

**Not available with manual transmission

†Not available with air conditioning

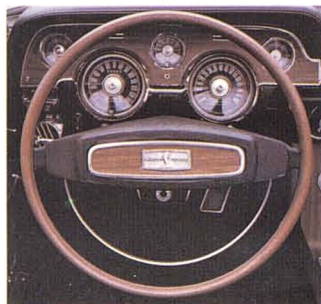

THESE FEATURES GIVE THE SHELBY COBRA GT ITS UNIQUE CHARACTER

Many of these features give the Cobra GT its exciting look—but the subtle engineering that you do not see is what you appreciate the more you drive this great car. (1) **Performance** is exciting with any of these four GT engine choices: GT 350, 250 hp 302 cu. in. V-8 (Cobra supercharger optional); GT 500, 360 hp 428 cu. in. V-8 (400 hp 427 cu. in. V-8 optional). Each engine features (2) high velocity, high volume Cobra intake manifold, (3) advanced design Holley cathedral float 4-barrel carburetion, (4) dual exhausts, (5) low restriction custom paper-element diecast aluminum air cleaner. Every engine looks the part, too, with (6) die cast aluminum Cobra rocker covers, chromed filler cap, dipstick. **Handling** is "right now" under all conditions, thanks to (7) high-rate front coil spring, (8) high capacity heavy-duty adjustable shock absorbers front and rear, (9) .94" diameter rear stabilizer bar, (10) crisp 16.0:1 steering ratio with power assist, (11) heavy duty four-leaf rear springs with (12) anti-windup dampers for sure acceleration, (13) heavy-duty rear axle. **Tires and brakes** match the GT's performance. (14) Power-assisted floating caliper front disc and (15) heavy duty rear drum brakes work with (16) true 4 ply nylon Goodyear Speedway 350 tires and (17) 6" rim width 15" safety wheels for utmost safety. Other safety items include (18) inertia-ree shoulder harnesses and seat belts for front-seat passengers (seat belts in rear), (19) integral overhead safety bar in all models, (20) safety-sequence wide tail lights, (21) front marker lights and (22) rear quarter reflectors, (23) rectangular fog lights and (24) dual master brake cylinder with proportioning valve and low-pressure warning light, (25) collapsible steering column and safety padded center steering wheel, (26) full unitized chassis and body.

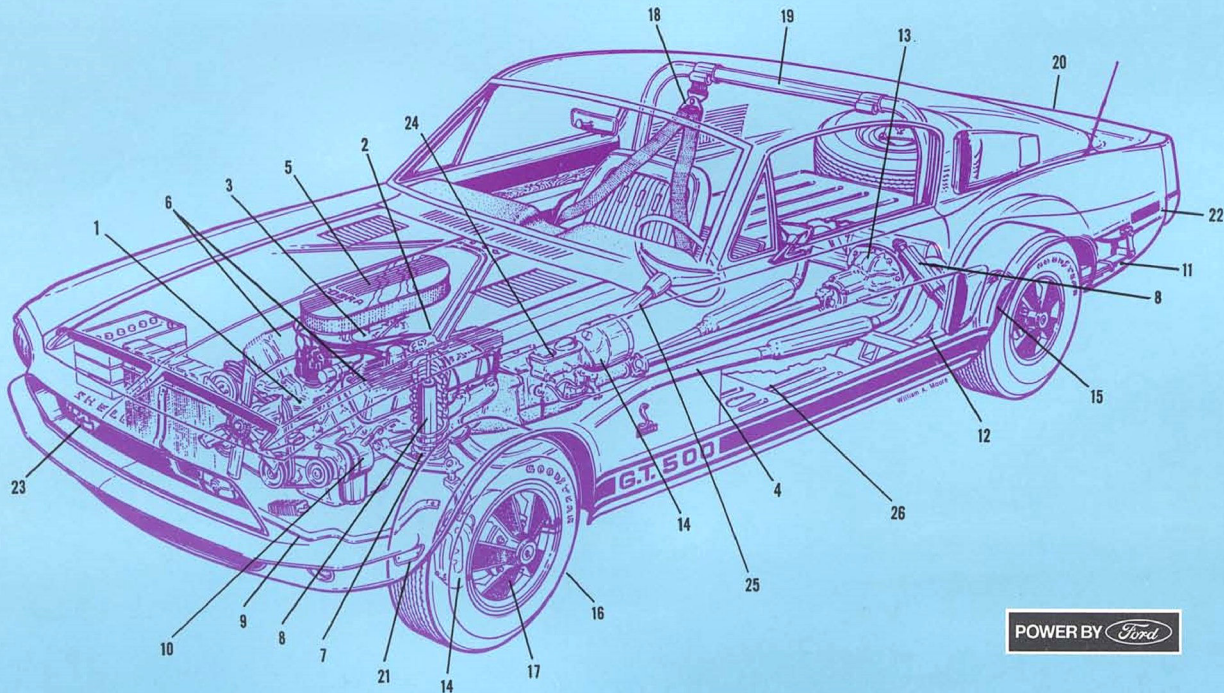

POWER BY 

Tailor your
GT 350 or GT 500
with this wide
selection of colors
and options



Color and Upholstery Choices

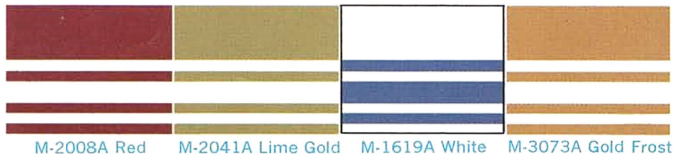

M-2008A Red M-2041A Lime Gold M-1619A White M-3073A Gold Frost



M-3077A Acapulco Blue M-1724A Black M-3067A Dark Green

- Interior trim:** black or saddle tan available with any exterior color
- Convertible top:** black or white available with any exterior color
- GT side stripe:** blue on white exterior, white on all other colors

Options Available

For GT 350 Only:

Cobra supercharger
4.11:1 and 4.56:1 final drive ratios

For GT 500 Only:

427 cu. in. hydraulic super-performance engine with automatic transmission
3.00:1, 4.11:1, 4.25:1 and 4.56:1 final drive ratios

For All Models: Performance

Ram air package (except supercharger GT 350)

Equa-lok rear axle
Automatic transmission (standard on super-performance 427 hydraulic engine).

Luxury, Convenience

AM radio
Rear quarter mounted antenna
Folding rear seat with luggage retaining bar (fastbacks only)
Integral air conditioning (except on super-charged GT 350) includes tinted glass

YOUR COBRA DEALER IS

