

Introducing
1992 LEMANS



AVAILABLE AT YOUR PONTIAC DEALER TODAY

LEMANS BY AUTOCOUPLE



LEMANS COCKPIT

The SE's command centre is outfitted for fans of serious highway fun. Easy-to-read analogue gauges present the most pertinent information, while performance-contoured seats ensure you optimum comfort for the cruise. Programming the sound-track to your journey is easy with the standard AM/FM stereo auto-reverse cassette tape player. In fact, once you get behind SE Aerocoupe's Deluxe Rally 3-spoke, thick-rim steering wheel, you'll find that cornering the market on driving excitement is very close at hand.

Five adults? No problem. The SE Sedan offers comfortable seating. Small children? Rear-door child security locks mean they're no problem either.



LEMANS SE SEDAN

Call it LeMans for all reasons. Precision-engineered and space-efficient inside and out. LeMans is generous on your budget, with a price almost anyone can handle. The SE's generous on the inside too, with 1067mm/42.0 in. of leg room up front, and 833mm/32.8 in. in back. Yet it's small when it comes to manoeuvrability and parking with a 10.0m/32.8 ft. turning circle. SE Sedan; a young family could easily call this LeMans a best friend.

LEMANS SE SEDAN



LEMANS AEROCOUCPE

Count on LeMans SE Aerocoupe to give you a fresh perspective on performance. Observe its monochromatic look.

The SE Aerocoupe boasts a fuel injected 1.6L 4-cylinder overhead cam engine that is poised for action. It's combined with a 5-speed gearbox, and a sport tuned exhaust, plus new 13" Styled Steel wheels.



LEMANS SE AEROCOUCPE

LEMANS VALUE LEADER AEROCOUCPE

Notice the aerodynamic style, front fascia, fog lamps and rear hatch spoiler. On the inside, you've got cargo room galore. Add a low sticker price to the equation, and you're looking at a brand of driving excitement that's more than the sum of its parts.

Good for openers, but start it up and let it speak to you. That's LeMans SE Aerocoupe. But if you need proof, there's a LeMans within your means, look no further than the LeMans Value Leader Aerocoupe. It really hauls in its own way with 534L (18.9 cu.ft.) of cargo space. More than you'd expect from a car in its class.

LEMANS FEATURES AND SPECIFICATIONS

INSTRUMENT CLUSTERS

- Standard cluster:** includes analogue speedometer, trip odometer, oil pressure, water, fuel and coolant temperature gauges. Standard on Value Leader Aerocoupe.
- Rally cluster:** includes analogue tachometer, speedometer, trip odometer, oil pressure, water, fuel and coolant temperature gauges. Standard on SE models.



1. Standard cluster.

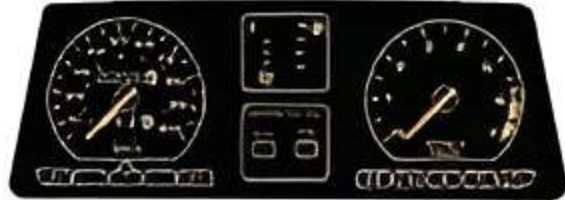

2. Rally cluster.

STEERING WHEELS

- Custom, 2-spoke steering wheel:** Standard on Value Leader Aerocoupe and SE Sedan.
- Drive Rally, 3-spoke steering wheel:** Standard on SE Aerocoupe.



1. 2-spoke steering wheel.

2. 3-spoke steering wheel.

RADIOS

UWA: Delta ETR AM/FM stereo radio with dual antenna, auto reverse cassette tape, preset and digital clock. Standard on SE models. Shows drive.



AM/FM radio with cassette

WHEELS & WHEEL COVERS

- Custom Styled 13" (x) wheel covers on 5.5" wide steel wheels:** Standard on Value Leader Aerocoupe and SE Sedan.
- Styled Steel 13" X 5.5" wheels:** Standard on SE Aerocoupe.



1.

2.

VITAL SPECS

curb weight (with the manual transmission)

Value Leader Aerocoupe	1603 kg (3,537 lb.)
SE Aerocoupe	1603 kg (3,537 lb.)
SE Sedan	1603 kg (3,537 lb.)
Fuel Tank	57L (15.0 gal.)
Tires	150R (14.0 cu ft.) Aerocoupe 403L (14.5 cu ft.) Sedan

ENGINE/TRANSMISSION TRANS

1.8L QVC 4-cylinder	4-speed manual 5-speed manual 3-speed automatic
---------------------	---

CHASSIS

Front Suspension: Fully independent with MacPherson struts
Level I 22 mm stabilizer bar
Rear Suspension: Semi-independent with coil springs
Level I 18 mm stabilizer bar

BRAKES

Front Power, vented disc	9.3"
Rear Power, drum	7.5"

STEERING TYPE

Manual, rack-and-pinion	24.5:1 ratio (Value Leader)
Power, rack-and-pinion	18.3:1 ratio (SE)
Tie rod, beam-to-axle	4.57 neutral (Value Leader) 3.50 power (SE)
Turning circle, diameter	10.0 m (32.8 ft.) curb-to-curb

TIRES

Level I	P175/70R13
---------	------------

INTERIOR mm (in.)

AEROCOUPÉ	
Head room, fr	915/1160 (30 1/2/35 1/2)
Leg room, fr	1017/1123 (42 0 1/2/44 1/2)
Shoulder room, fr	1201/1160 (51 2 1/4/46 1/4)
Hip room, fr	1204/1160 (51 3 1/4/46 1/4)

SEDAN

Head room, fr	915/1160 (30 1/2/35 1/2)
Leg room, fr	1017/1123 (42 0 1/2/44 1/2)
Shoulder room, fr	1201/1160 (51 2 1/4/46 1/4)
Hip room, fr	1204/1160 (51 3 1/4/46 1/4)

COUPE

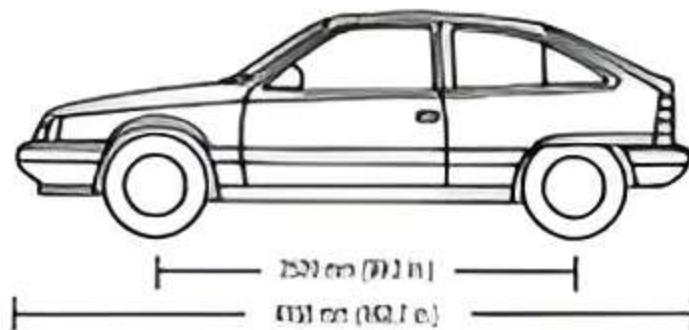
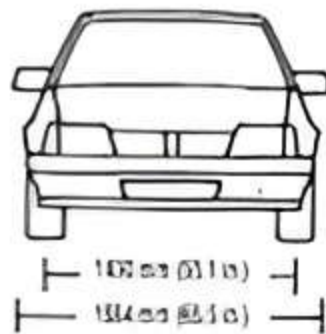

SEDAN

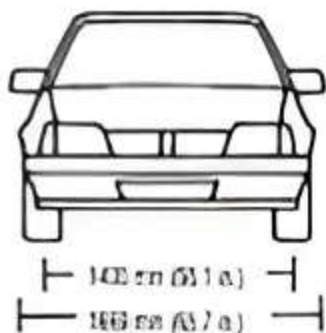

STANDARD EQUIPMENT	VALUE LEADER AERO COUPE	SE AERO COUPE	SE SEDAN
Brakes: Power front disc/rear drum	S	S	S
Cargo security cover	S	S	S
Child safety rear door locks			S
Collision protection			S
Wash/waxer jets on structural steel components or are not included	S	S	S
Washer: Electric rear window	S	S	S
Over the top pockets		S	S
Fog Lamps		S	S
Glass: Laminated safety, tinted		S	S
Swing-out rear quarter		S	S
Headlamps: On/off auto halogen with Daytime Running Lamps	S	S	S
Headlamps: front and adjustable	S	S	S
Lamp Guard	S	S	S
Locking system: Driver key	S	S	S
Mirror: front, UV resistant/mirrored	S	S	S
Spill: UV resistant		S	S
Wash/waxer: not covered		S	S
Weatherstrips: with body-color (except column/trim/vents)	S	S	S
Seats: Bucket front bucket	S	S	S
Fuel: fueling rear seat with latch	S	S	S
Suspension: Sport tuned	S	S	S
Tires: full size spare wheel and tire	S	S	S
Windshield wiper: intermittent	S	S	S

OPTIONAL EQUIPMENT GROUPS

To help simplify the buying process, the 1991 LeMans SE has optional equipment (equipment Groups P, L, G, X). Check the equipment group you desire. Some restrictions apply. See your local representative for details and availability of optional equipment.

MODELS	LeMans					
	Value Leader Aerocoupe	SE Aerocoupe		SE Sedan		
P, L, G, ORDERING CODE	13A	11B	11C	11D	11E	11F
Transmission: 4-speed manual	.					
Transmission: 5-speed manual		.		.		
Transmission: 3-speed automatic			.		.	.
Steering: power	
Air conditioning					.	.

Ask your dealer for details on GM's now for 1002 TOTAL™ Warranty - 3 years or 60,000 km* NO DEDUCTIBLE

*Whichever comes first

A WORD ABOUT THIS BROCHURE

The vehicles described in this brochure incorporate components produced by General Motors of Canada Limited and related companies and suppliers. During manufacturing different components than initially scheduled may be used.

All illustrations and specifications contained in this brochure are based on the latest production information at the time of publication approval. The right is reserved to make changes at any time, without notice, in price, colour, materials, equipment, specifications and models, and to discontinue models. Some of the equipment shown or described throughout this brochure is available at extra cost, or can be ordered in conjunction with the other optional equipment. Some options may not be available when your vehicle is built. Check with your dealer for complete information.

NOTE: Instruments shown throughout this brochure are metric in Canada. Vehicles in Canada are equipped with automatic Daytime Running Lamps. Front seat belt system illustrated in this brochure differs in Canada.

General Motors, GM, the GM emblem, Pontiac, the Pontiac emblem, Delta ETR and the TOTAL Warranty are all trademarks of General Motors Corporation and/or General Motors of Canada Limited.

Printed in Canada, September 1991
© 1991, General Motors of Canada Limited



100% recycled paper

